

LS2000 LEVEL SWITCH OWNERS MANUAL

INSTALLATION and CALIBRATION

Distributed by:
iProcesSmart.com Tel: (; 47)928-9655 Fax: (; 47)928-47: 5 E-Mail: sales@iprocessmart.com Online: http://www.iprocessmart.com/

**BABBITT
INTERNATIONAL, INC.**

GENERAL DESCRIPTION

The LS2000 is a point switch that detects the presence or absence of material in a bin silo, tank or other container. The basic unit is made up of a solid stainless steel probe attached to an explosion proof housing. Inside the explosion proof housing are all calibration adjustments and sensing electronics. The unit is calibrated in the absence of material and an internal relay changes state when material is detected.

THEORY OF OPERATION

The LS2000 employs a radio frequency (RF) balanced impedance bridge circuit to detect if the probe is in contact with the material that is to be sensed. When material is not in contact with the probe, the bridge is balanced by turning the adjustment pot to find the threshold where the red L.E.D. goes out. When material is in contact with the probe, the bridge comes unbalanced and the comparing circuit realizes the change. This causes the relay to change state.

INSTALLATION

***CAUTION:** ALL INSTALLATION AND WIRING MUST CONFORM TO NEC AND ALL OTHER LOCAL ELECTRICAL CODES. TAKE SPECIAL CARE IN OBSERVING HAZARDOUS AREA SAFETY PROCEDURES. WE ASSUME NO LIABILITY FOR IMPROPERLY INSTALLED OR WIRED UNITS.

INSPECTION AND OPERATION

After unpacking the LS2000 visually inspect the unit for any damages. Please advise the factory or your local distributor of any damage.

Before installing the unit, a simple operational check can be performed.

On the bench, hook up the appropriate power to L1 and L2. The operating voltage of the LS2000 is marked on the power supply board. Hold the unit so that the probe is not touching any surface and touch the probe. When you touch the probe, the red led should come on.

This simulates product touching the probe.

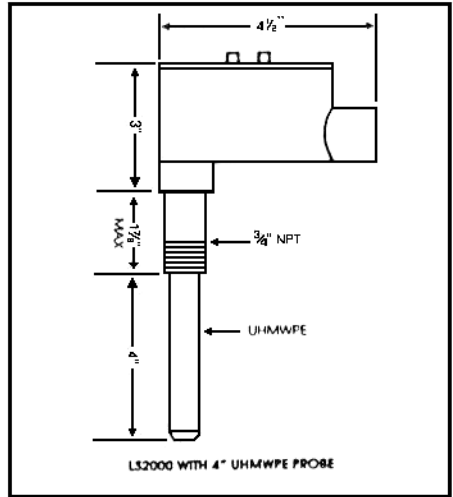
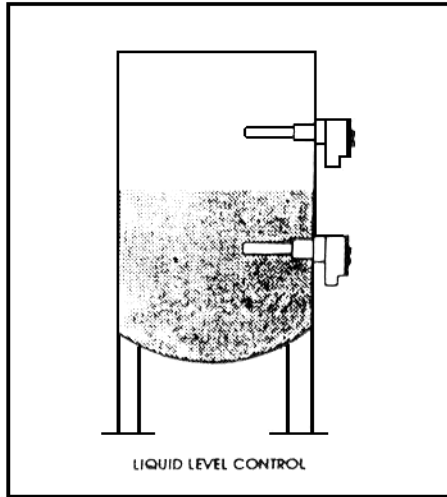
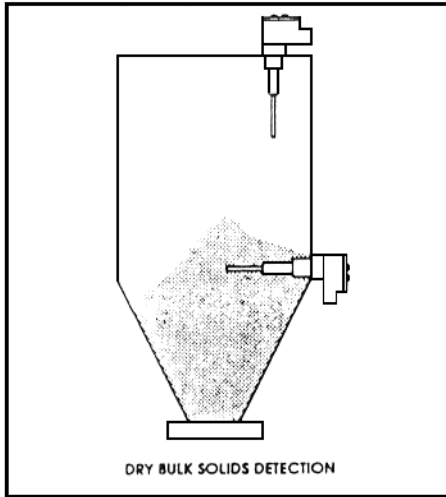

SPECIFICATIONS

ELECTRICAL

- Power: 120 VAC ($\pm 15\%$) 60 Hz, 2 watts, standard (24 VDC optional)
- Output: 1 Form C contact SPDT relay, 10 amp resistive at 125 VAC, 8A250VAC, 5A30VDC
- Fail Safe: Selectable high or low level
- RF Frequency: Approximately 1.3 MHz

ENVIRONMENTAL

- Hazardous Area: Class I, Group C, D, Class II, Group E, F G, Class III
- Temperature: Probe: -30°F to 180°F
Electronics: -30°F to 170°F
- Pressure: Probe 250 psi @ 75°F Note: at 180°F pressure should not exceed atmosphere.
- Construction: Probe: All wetted parts 316 SS, UHMWPE and Viton.
Electronics: Housed in cast aluminum explosion proof enclosure.

Specifications subject to change without notice.

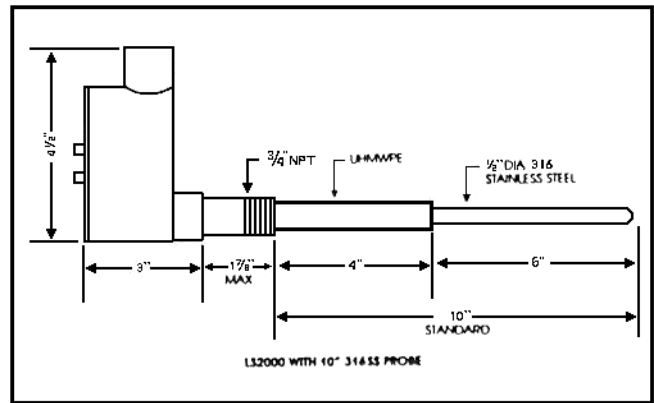

Physical Installation

- 1) The LS2000 is installed into the vessel wall using a connection. This can be either a threaded coupling or a tapped entry such as a flange.
- 2) The insulator should always extend at least 2" through the vessel wall.
- 3) Always check for physical room around the location you have chosen to allow for installation. Allow 3.75" turning radius to screw the probe in and clearance above for the length of the probe.
- 4) **CAUTION:** Always take the necessary safety precautions when cutting or welding in the coupling for the LS2000.
 - a) Tag and lock out the electrical power to the equipment that services the vessels.
 - b) Check liquid or dry powders that create a gas in the vessel for oxygen as well as the explosion factor. (All dust will explode.)
 - c) Vessels that are cross vented have to be isolated.
- 5) Screw the LS2000 into the connection provided. In dry material application, no sealant on threads is required. On liquid, teflon or a good pipe thread sealant may be used.
- 6) The LS2000 has a 3/4" conduit entry. When wiring these units, conform to the National Electrical Code and any other city or company codes.
- 7) Always install the electrical connection into the 3/4" conduit entry on the LS2000 so water will not follow the connection routing into the threads of the conduit hub. To guarantee that condensation and water will stay outside the unit, install an EYSM unilet before each LS2000 and fill with explosion proof sealing cement.

Removing the Electronics

- 1) Disconnect supply power at main power source
 - 2) Disconnect wires from terminal strip
 - 3) Unplug blue antenna lead
 - 4) Remove green grounding screw
- To reinstall, reverse the above procedure.

LS 2000 TERMINAL LAYOUT

10 AMP RELAY CONTACTS

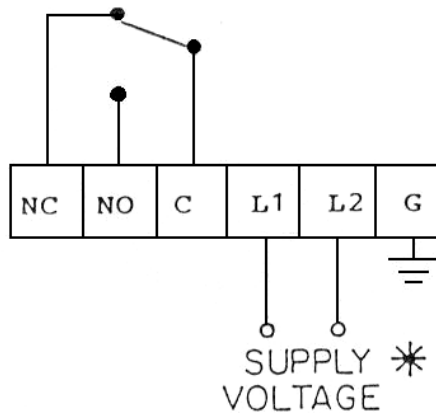

* NOTE: EACH LS 2000 POWER SUPPLY IS INTENDED FOR ONLY ONE SUPPLY VOLTAGE. THIS VOLTAGE IS PRINTED ON THE POWER SUPPLY BOARD.

FOR 115 VAC UNITS HOOK UP THE HOT LEAD TO L1 AND THE NEUTRAL TO L2, WITH APPROPRIATE GROUND.

24 VDC UNITS HOOK THE POSITIVE VOLTAGE TO L1 AND THE COMMON OR GROUND TO L2.

TYPICAL WIRING

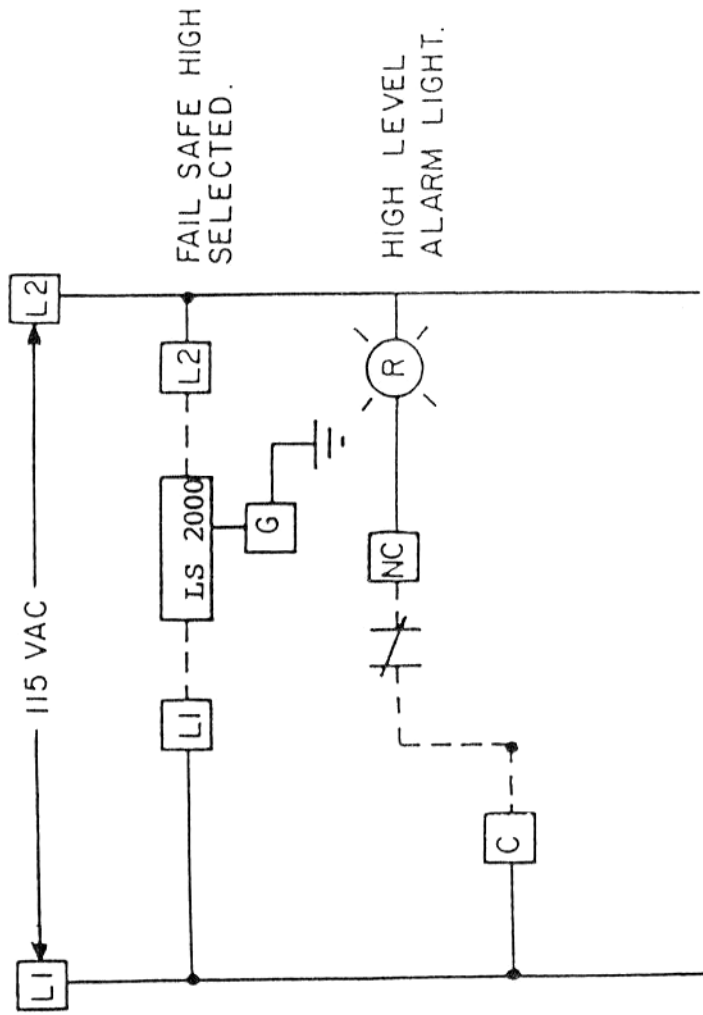

NOTE:
PLEASE REVIEW FAIL SAFE
INSTUCTIONS

APPLICATION

HIGH LEVEL ALARM

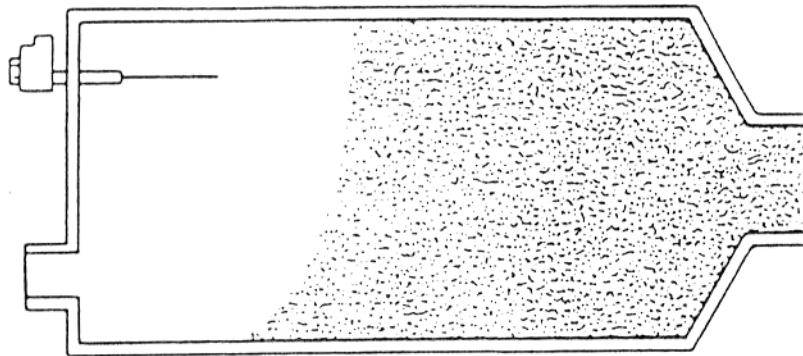

APPLICATION

AUTOMATIC FILLING OF TANK.
 (WHEN LEVEL FALLS TO POINT "A", A PUMP COMES ON TO FILL TO POINT "B", THEN TURNS OFF.)

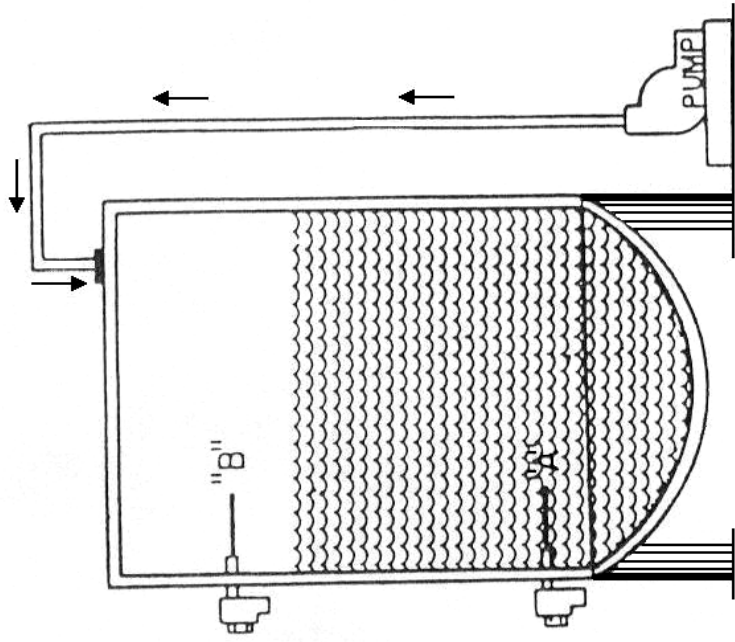

TYPICAL WIRING

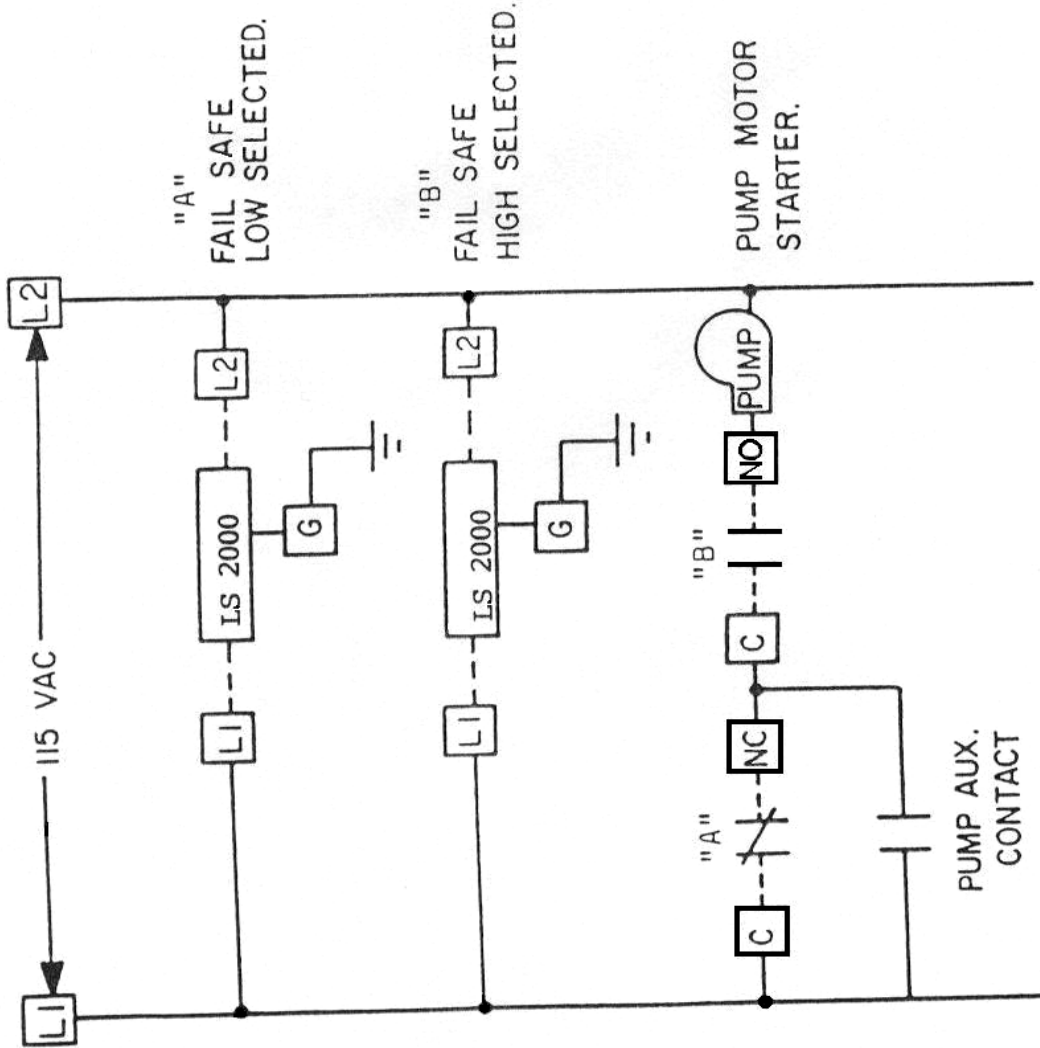

CALIBRATION INSTRUCTIONS

PLEASE READ THE ENTIRE CALIBRATION PROCEDURE BEFORE CALIBRATING

A. Fail Safe Selection

The fail safe feature provides a “false alarm” in case of power outage or major component failures. When properly selected, the fail safe feature can protect equipment or alert you of a unit failure.

Fail Safe High (FSH) means that the relay is energized when NO PRODUCT is touching the probe. When product comes into contact with the probe, the relay is de-energized.

Fail Safe Low (FSL) means that the relay is energized when PRODUCT IS touching the probe.

Fail Safe High or Fail Safe Low is selected by plugging the jumper next to the transformer in the appropriate position.

NOTE: Due to the wide variety of applications and possible control or alarm functions, the proper fail safe selection will depend on your circumstances. Please call your distributor or the factory if you need assistance.

B. Sensitivity Calibration

The LS2000 should be calibrated when no material is touching the probe and when the unit is installed where it will be used.

- 1) Observe the red LED. If it is on, go to step 3.
- 2) If the red LED is off, turn the sensitivity adjustment potentiometer clockwise (CW) until it comes on.
- 3) Turn the sensitivity adjustment pot counter-clockwise (CCW) until the red LED just goes out. This sets the unit to its maximum sensitivity. If in your application this is too sensitive, you can turn the sensitivity adjustment pot further CCW; usually $\frac{1}{4}$ to $\frac{1}{2}$ turn is sufficient to reduce the units sensitivity. Always bring the product into contact with the probe after calibration to assure proper performance.

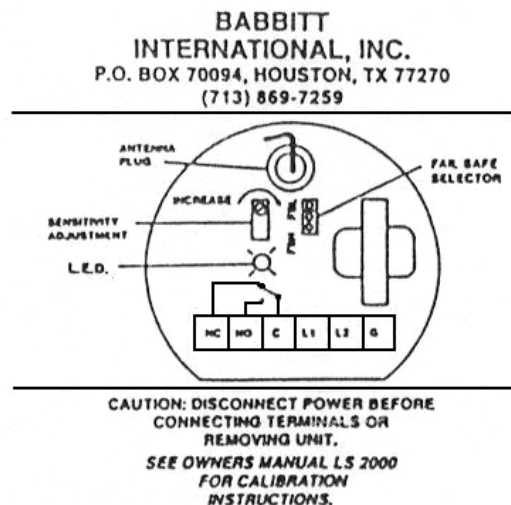

WARRANTY

All components of the LS2000 are warranted to be free from defects in material and workmanship for a period of two years from the date of purchase. This warranty applies to general purchaser and to components installed, serviced and operated according to instructions. Babbitt International, Inc. will repair or replace, at its option, FOB at its plant or any other location designated, any part which proves to be defective in manufacture or workmanship. All claims must be made in writing within the warranty period. No claims outside of the warranty period will be honored.

Warranties are not applied to any components which have been damaged by improper installation, use, exposure to unusual atmospheric conditions or components which have been misused, abused, damaged by neglect or accident. This warranty shall not apply to any components which have been altered or repaired without the prior written consent of Babbitt International, Inc.

Babbitt International, Inc. assumes no responsibility or liability for any labor or material back charges, without written authorization. Any products returned must be with prior written authorization.

THE FOREGOING IS IN LIEU OF ALL OTHER WARRANTIES, EXPRESSED OR IMPLIED, INCLUDING ANY WARRANTIES OF MERCHANTABILITY AND/OR FOR FITNESS FOR PARTICULAR PURPOSE, AND BABBITT INTERNATIONAL, INC. ASSUMES NO OTHER LIABILITIES EXPRESSED OR IMPLIED. BABBITT INTERNATIONAL, INC. SHALL NOT BE LIABLE FOR NORMAL WEAR AND TEAR, NOR FOR DIRECT, INCIDENTAL OR CONSEQUENTIAL DAMAGES. IN NO EVENT SHALL BABBITT INTERNATIONAL INCORPORATED'S LIABILITY EXCEED THE PRICE OF ITS PRODUCT AT THE TIME OF PURCHASE.