

**LS7000/2**  
**DUAL POINT LEVEL SWITCH**  
**OWNERS MANUAL**

- ◆ **INSTALLATION**
- ◆ **CALIBRATION**
- ◆ **TROUBLESHOOTING**
- ◆ **WARRANTY**

**BABBITT**  
**INTERNATIONAL, INC.**

---

## TABLE OF CONTENTS

	Page
1. <u>Description -----</u>	<u>1</u>
<u>A. General Description -----</u>	<u>1</u>
<u>B. Specifications -----</u>	<u>1</u>
<u>C. Ordering Information -----</u>	<u>1</u>
2. <u>Theory of Operation -----</u>	<u>2</u>
3. <u>Installation-----</u>	<u>2</u>
<u>A. Inspection -----</u>	<u>2</u>
<u>B. Physical Installation -----</u>	<u>2</u>
<u>C. Removing Electronics-----</u>	<u>2</u>
<u>D. Typical Applications and Wiring Diagrams -----</u>	<u>3-5</u>
4. <u>Calibration -----</u>	<u>6</u>
<u>A. Setting S1 and S2 -----</u>	<u>6</u>
<u>B. Setting Sensitivity Switch -----</u>	<u>6</u>
<u>C. Calibrate the Low Setpoint-----</u>	<u>6</u>
<u>D. Calibrate the High Setpoint -----</u>	<u>7</u>
5. <u>Maintenance and Troubleshooting -----</u>	<u>7</u>
6. <u>Warranty -----</u>	<u>8</u>

# LS7000/2 LEVEL SWITCH

## 1. DESCRIPTION

### A. General Description

The LS7000/2 dual point level switch is designed to automatically maintain a level between two points along a vertically mounted probe. The two setpoints are adjustable over the entire length of the probe. The LS7000/2 can be used to automatically fill a tank, or automatically pump down a sump. A single relay, DPDT, 5 amp, is used for control. An on board latching circuit prevents the relay from changing state until the high or low setpoints are reached. The basic unit is made up of a solid stainless steel probe attached to an explosion proof housing. Inside the explosion proof housing are all calibration adjustments and sensing electronics. Whenever the LS7000/2 is used in electrically conductive materials, a coated probe (not bare steel rod) must be used.

### B. Specifications

#### Electrical

Power: 115 VAC ( $\pm 15\%$ ) 50/60 Hz. 2 watts, standard.  
(12 VDC, 24 VDC or 230 VAC optional)

Output: 2 Form C contacts, DPDT relay, 5 amp resistive  
at 125, 250 VAC; 30 VDC

Fuse: On board, 0.5A @ 125 volts

RF Frequency: Approximately 1.3 MHz

#### Environmental

Hazardous Area: Class I, Group D, Class II, Group E, F, G

Temperature: Probe:  $-30^{\circ}$  F to  $400^{\circ}$  F  
Electronics:  $-40^{\circ}$  F to  $185^{\circ}$  F

Pressure: Probe: 1500 psi @  $175^{\circ}$  F. Higher ranges available on request.

Construction: Probe: All wetted parts, 316 SS, Teflon and Viton. (A halar coating can be applied.)  
Electronics: Housed in cast aluminum explosion proof enclosure.

Specifications subject to change without notice.

### C. Ordering Information

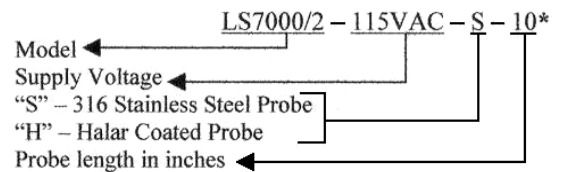
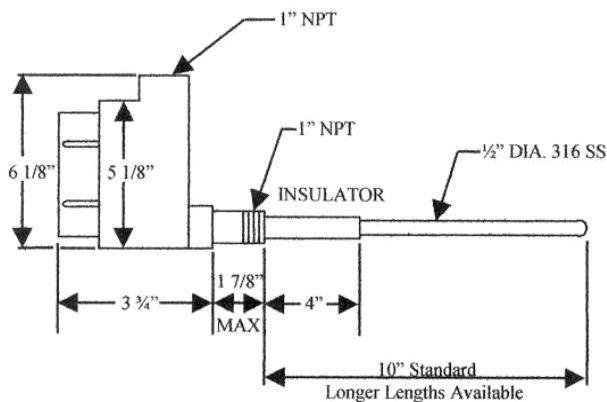

\*This describes an LS7000/2, powered by a 115 VAC, with a 316 SS probe, 10" long. The probe length is measured from the end of the nipple to the tip of the probe.

FIGURE 7.2.1

## 2. THEORY OF OPERATION

The LS7000/2 employs a radio frequency (RF) balanced impedance bridge circuit to detect the level of material along the probe.

As fluid level rises along the probe, the output of the bridge changes proportionally to the fluid level. The setpoint potentiometers determine at what level the circuit detects the low and high setpoints.

An on-board dip switch (S2) determines automatic fill or automatic empty operation. S1 determines the power-on-reset mode if the level is between the two setpoints when power is interrupted to the unit.

## 3. INSTALLATION

**\*CAUTION:** ALL INSTALLATION AND WIRING MUST CONFORM TO NEC AND ALL OTHER LOCAL ELECTRICAL CODES. TAKE SPECIAL CARE IN OBSERVING HAZARDOUS AREA SAFETY PROCEDURES. WE ASSUME NO LIABILITY FOR IMPROPERLY INSTALLED OR WIRED UNITS.

### A. Inspection

After unpacking the LS7000/2, visually inspect the unit for any damages. Please advise the factory or your local distributor of any damage.

### B. Physical Installation

- 1) The LS7000/2 is installed vertically into a vessel using a 1" NPT connection.
- 2) Always check for physical room around the location you have chosen to allow for installation. Allow 5 ½" turning radius to screw the probe in, and clearance above for the length of the probe.
- 3) CAUTION: Always take the necessary safety precautions when cutting or welding in the coupling for the LS7000/2.
  - a) Tag and lock out the electrical power to the equipment that services the vessel.
  - b) Check for explosion hazards before cutting or welding the mounting coupling for the LS7000/2.
- 4) Screw the LS7000/2 into the connection provided.
- 5) The LS7000/2 has a 1" NPT conduit entry. The wiring of these units should conform to the National Electrical Code and any other city or company codes.

### C. Removing the Electronics

- 1) To remove the sensing card, simply unplug it from the power supply card. When reinstalling, this card is made so that it cannot be plugged in backwards.
- 2) To remove the power supply card you must:
  - a. Disconnect supply power at main power source
  - b. Remove sensing card
  - c. Disconnect wires from terminal strip
  - d. Remove green grounding screw
  - e. Unplug blue antenna lead
  - f. Hold the top of the card guide and lift outTo reinstall, reverse the above procedure.

### D. Typical Applications and Wiring Diagrams

- |  |        |
|--|--------|
| 1. LS7000/2 Terminal Layout            | Page 3 |
| 2. Power Supply Board and Sensing Card | Page 4 |
| 3. Ladder Diagrams                     | Page 5 |

LS 7000 / 2  
TERMINAL LAYOUT

5 AMP RELAY CONTACTS

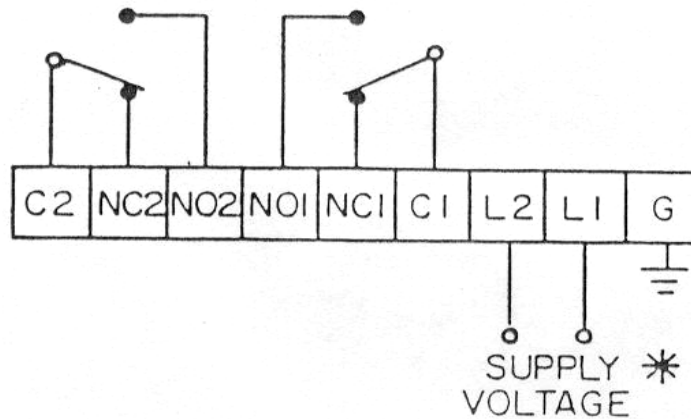

\* NOTE: EACH LS7000/2 POWER SUPPLY IS INTENDED FOR ONLY ONE SUPPLY VOLTAGE. THIS VOLTAGE IS PRINTED ON THE POWER SUPPLY BOARD.

FOR 115 VAC OR 230 VAC UNITS HOOK UP THE HOT LEAD TO L1 AND THE NEUTRAL TO L2, WITH APPROPRIATE GROUND.

FOR 12 VDC OR 24 VDC UNITS HOOK THE POSITIVE VOLTAGE TO L1 AND THE COMMON OR GROUND TO L2.

FIGURE 7.2.2

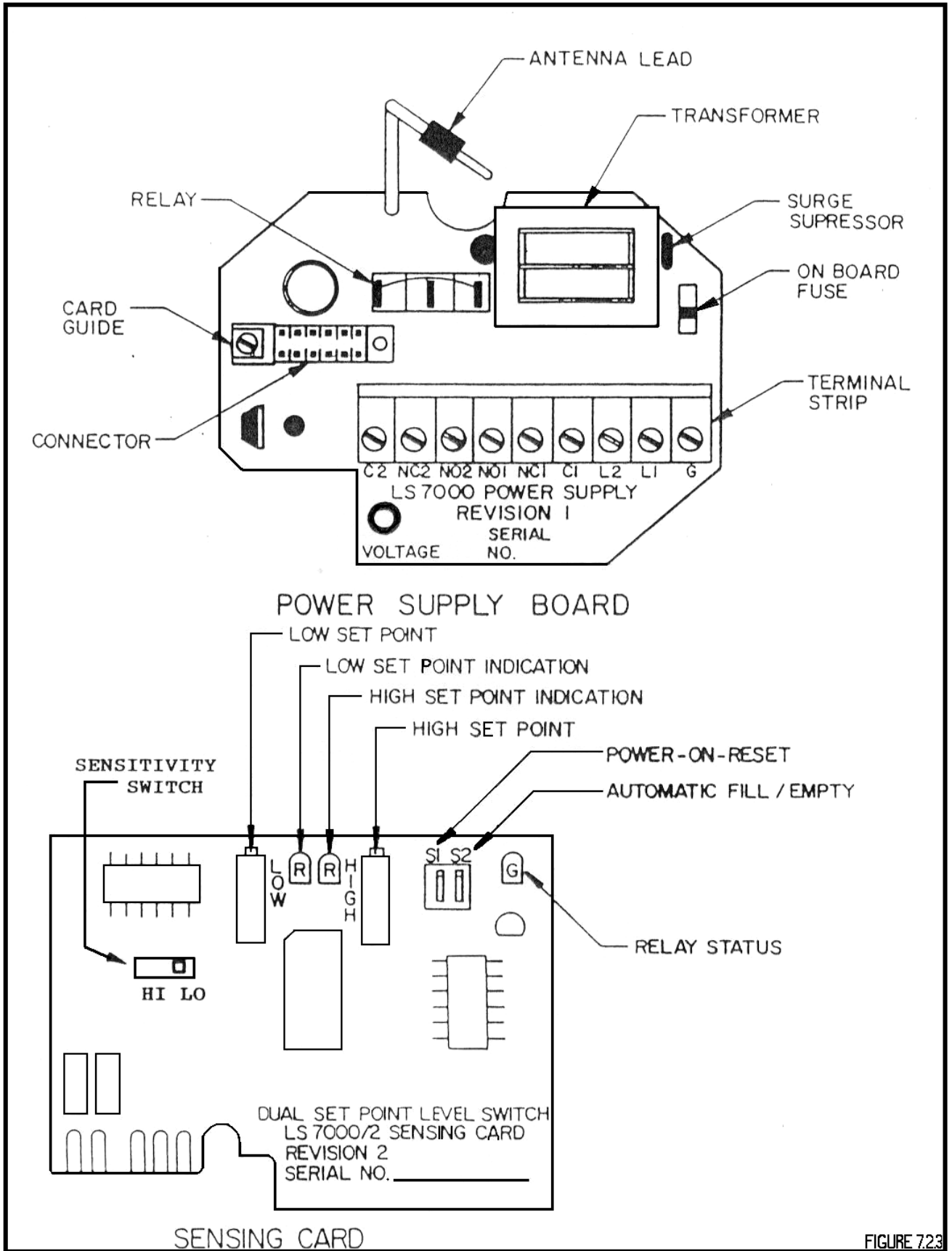
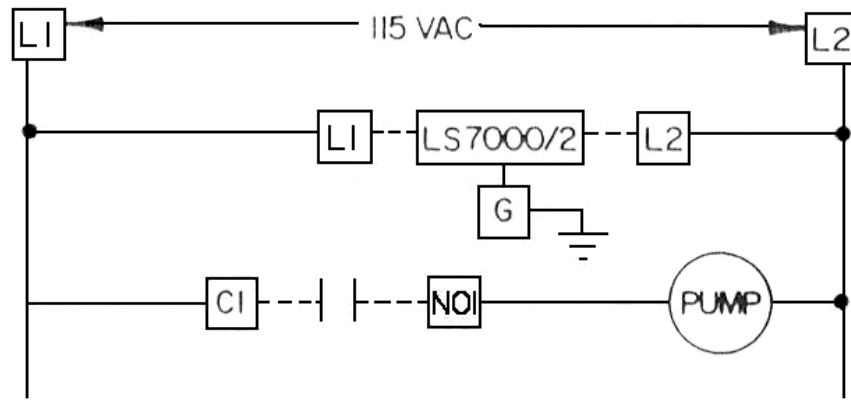
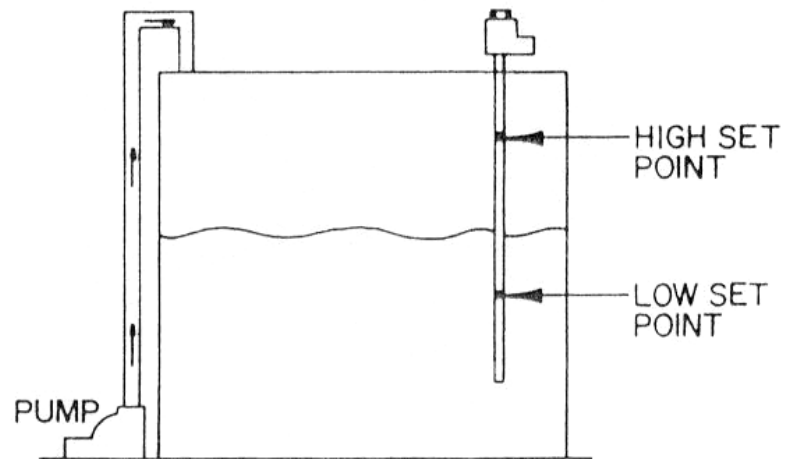

FIGURE 723



SI AND S2 SET FOR AUTO FILL



WHEN THE FLUID LEVEL FALLS TO THE LOW SET POINT, THE INTERNAL RELAY WILL ENERGIZE AND START THE PUMP. THE PUMP WILL CONTINUE TO RUN UNTIL THE FLUID LEVEL REACHES THE HIGH SET POINT, THEN THE PUMP WILL SHUT OFF.

FIGURE 7.2.4

#### 4. CALIBRATION

PLEASE READ THE ENTIRE CALIBRATION PROCEDURE BEFORE CALIBRATING THE LS7000/2.

##### A. Setting S1 and S2

Switches S1 and S2 are the dip switches on the LS7000/2 sensing card. S2 selects automatic fill or automatic empty.

“AUTOMATIC FILL” is when the relay energizes below the low setpoint and de-energizes below the high setpoint.

“AUTOMATIC EMPTY” is when the relay energizes at the high setpoint and de-energizes below the low setpoint.

The green LED indicates relay status. The green LED is on when the relay is energized.

When S2 is UP, “AUTOMATIC FILL” is selected.

When S2 is DOWN “AUTOMATIC EMPTY” is selected.

S1 is used to select the “POWER-ON-RESET” mode of the LS7000/2, if the supply voltage should be interrupted while the fluid level is between the low and high setpoints. If the unit should lose power and the level is between the setpoints, the LS7000/2 can not “remember” if it was filling or emptying at the time of power loss. By properly setting S1 for your application, the relay will either energize or de-energize when power is restored to the unit. If the fluid level is below the low setpoint or above the high setpoint, S1 has no effect on the operation of the unit.

The chart below will help you set S1 and S2:

S1	S2	FILL/EMPTY	Power On Reset
UP	UP	AUTO FILL	RELAY OFF
<b>DOWN</b>	<b>UP</b>	<b>AUTO FILL</b>	<b>RELAY ON</b>
DOWN	DOWN	AUTO EMPTY	RELAY OFF
<b>UP</b>	<b>DOWN</b>	<b>AUTO EMPTY</b>	<b>RELAY ON</b>

##### B. Setting the Sensitivity Switch

The LS7000/2 plug in board has a 2 position slide switch to set the sensitivity.

As a rule of thumb, use low sensitivity for conductive liquids or long probes. High sensitivity is for non-conductive liquids or short probes. (See diagram on page 4 for switch location)

##### C. Calibrate the Low Setpoint

There are two ways to calibrate the low setpoint. Method “A” puts the setpoint on the bottom tip of the probe. Method “B” is for applications where the low setpoint needs to be above the tip of the probe.

###### METHOD “A”

1. When no product is in contact with the probe, observe the red LED for the low setpoint. If it is on, go to step 3.
2. If the red LED for the low setpoint is off, turn the low adjustment potentiometer CW until it comes on.
3. Turn the low adjustment potentiometer CCW until the low red LED just goes out.

###### METHOD “B”

1. Raise the fluid level to where you want the low setpoint to be on the probe.
2. Observe the red LED for the low setpoint. If it is off, go to step 4.
3. If the red LED is on, turn the low adjustment potentiometer CCW until the red LED goes out.
4. Turn the low adjustment potentiometer CW until the low red LED just comes on.



### C. Calibrate the High Setpoint

As a rule of thumb, clockwise (CW) rotation of the pot lowers the setpoint; counter-clockwise (CCW) rotation of the potentiometer raises the setpoint.

- 1) Raise the fluid level to where you want the high setpoint to be on the probe.
- 2) Observe the high red LED. If it is off, go to step 4.
- 3) If the high red LED is on, turn the high adjustment pot CCW until the high red LED goes out.
- 4) Turn the high adjustment pot CW until the high red LED just comes on. This adjustment must be made very carefully.

**NOTE:** Always fill and empty the vessel to verify the accuracy of the calibration. Repeat the above procedure if necessary. Contact your local distributor or the factory if you have any questions.

### 5. MAINTENANCE AND TROUBLESHOOTING

No routine maintenance is required other than to keep the interior of the unit clean and free of dirt, moisture and other contaminants.

The LS7000/2 consists of three main sub-assemblies. These are the enclosure with the probe, the power supply board and the sensing card. The following troubleshooting guide will assist in determining how to correct most of the problems, which may occur in the field.

<b>PROBLEM</b>	<b>POSSIBLE CAUSE</b>	<b>SOLUTION</b>
RED LED cannot be adjusted to turn on.	<b>Antenna lead not connected.</b> No power to unit. <b>Blown onboard fuse.</b> Bad sensing card.	<b>Plug antenna lead into probe.</b> Check power to unit. <b>Replace fuse.</b> Repair/replace card.
RED LED remains on at all times	Antenna probe is shorted to case or ground.  <b>Bad sensing card.</b>	Unplug module and position it so that the bare end is not touching anything. Turn calibration pot 20 turns CCW. LED should go out. If so, repair, replace or clean antenna probe. <b>Repair or replace card.</b>
High & low setpoints cannot be separated.	Bare steel probe being used on conductive fluid.	Insulate or replace probe.
Unit triggers when material touches probe, but will not reset when material recedes from probe or unit and gives false alarm.	<b>Improper mount of probe.</b> Improper calibration procedure. Excessive material build-up on probe.  <b>Probe is mounted in flow of material.</b>	<b>Contact factory or dist.</b> See section 4C. Perform “dirty probe calibration”: Recalibrate with built up material on probe. See section 4C. <b>Revise mounting or use time delay. See sec. 4A.</b>
Unit will not detect material.	Improper calibration.. <b>Antenna lead not plugged into probe.</b> Unit was calibrated with material touching probe.	See calibration section 4A. <b>Plug antenna lead into probe.</b>  Recalibrate without anything touching probe.
Unit will not stay in calibration.	<b>Poor grounding or unit to vessel.</b>	<b>Provide secure ground connection.</b>
Relay operates properly, but no signal at terminals.	Burned or broken lands on power supply printed circuit board.  <b>Bad relay contacts.</b>	Turn off power. Remove module from housing and inspect lands on printed circuit for damage. Replace as necessary. <b>Replace relay or return for repair.</b>

**PLEASE CONTACT THE FACTORY OR YOUR LOCAL DISTRIBUTOR IF YOU HAVE ANY QUESTIONS OR NEED ASSISTANCE.**

## 6. WARRANTY

All components of the LS7000/2 are warranted to be free from defects in material and workmanship for a period of two years from the date of purchase. This warranty applies to general purchaser and to components installed, serviced and operated according to instructions.

Babbitt International, Inc. will repair or replace, at its option, FOB at its plant or any other location designated, any part which proves to be defective in manufacture or workmanship.

All claims must be made in writing within the warranty period. No claims outside of the warranty period will be honored.

Warranties are not applied to any components which have been damaged by improper installation, use, exposure to unusual atmospheric conditions or components which have been misused, abused, damaged by neglect or accident. This warranty shall not apply to any components, which have been altered or repaired without the prior written consent of Babbitt International, Inc.

Babbitt International, Inc. assumes no responsibility or liability for any labor or material back charges, without written authorization. Any products returned must be with prior written authorization.

THE FOREGOING IS IN LIEU OF ALL OTHER WARRANTIES, EXPRESSED OR IMPLIED, INCLUDING ANY WARRANTIES OF MERCHANTABILITY AND/OR FOR FITNESS FOR PARTICULAR PURPOSE, AND BABBITT INTERNATIONAL, INC. ASSUMES NO OTHER LIABILITIES EXPRESSED OR IMPLIED. BABBITT INTERNATIONAL, INC. SHALL NOT BE LIABLE FOR NORMAL WEAR AND TEAR, NOR FOR DIRECT, INCIDENTAL OR CONSEQUENTIAL DAMAGES. IN NO EVENT SHALL BABBITT INTERNATIONAL INCORPORATED'S LIABILITY EXCEED THE PRICE OF ITS PRODUCT AT THE TIME OF PURCHASE.