

Y-Pattern and Diaphragm Valves



Advantages/Benefits

- ▶ Complete and modularly designed accessory program
- ▶ More for less: Configuration costs are only for what is required
- ▶ Easy maintenance and commissioning
- ▶ Increase system and operational safety

Design

The modular designed accessory option package is a comprehensive addition to the Burkert Y-pattern and diaphragm valve Types 2000, 2001, 2030, and 2031.

The flexible, easy-to-use concept of modular accessories has been designed to cover individual application requirements in a cost-effective way.

The design has been optimized for easy installation, retrofitting, commissioning, and operation.

- Flexible and versatile modular accessory program
- Easy to retrofit
- Increase operational safety

Applications

- Electrical feedback:
- Mechanical or inductive switches
 - Externally mounted magnetic/ inductive switches

Electrical feedback with optical position indication

Max. stroke limitation

Min./max. stroke limitation

Manual override

Namur-adaptor for pilot valves

Burkert Contromatic USA
2602 McGaw Avenue
Irvine, CA 92614
Tel. 949.223.3100
Fax 949.223.3198
www.burkert-usa.com

Burkert Contromatic Inc.
760 Pacific Road, Unit 3
Oakville, Ontario, Canada
L6L 6M5
Tel. 905.847.5566
Fax 905.847.9006



Dimensions [inch]

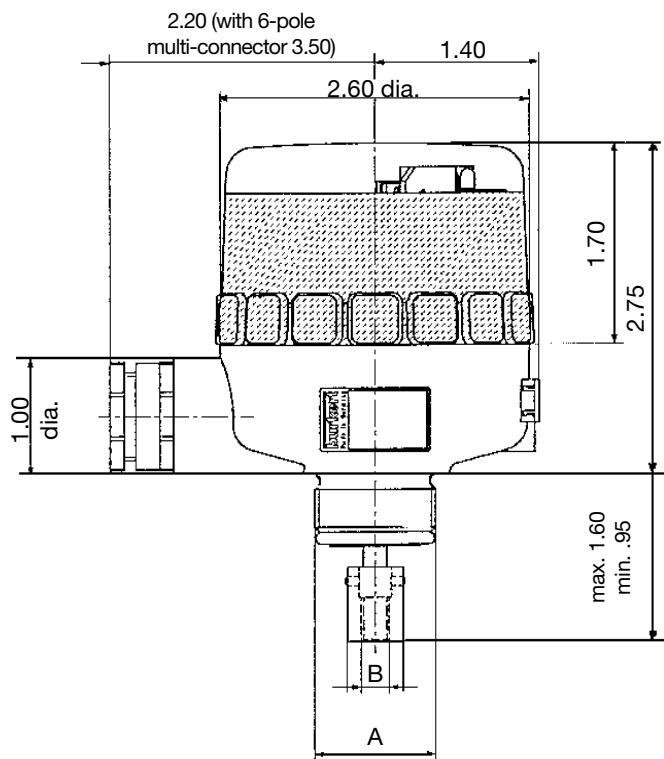

Actuator Size	A	B
D, E, F	M26x1.5	M6
G, H	M36x2	M1

Dimensions for Type 2000 [inch]

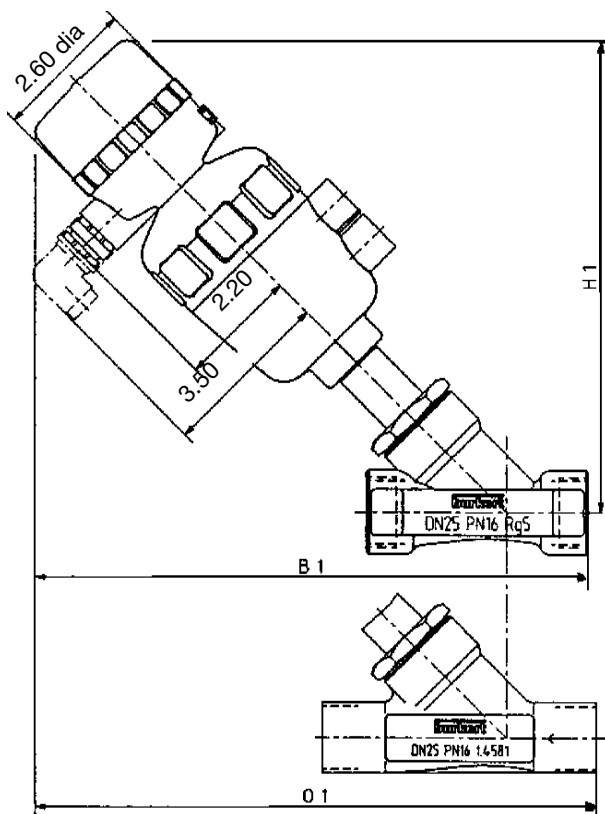

Specifications

Valve Size [inch]	Actuator Size	B1	H1	O1
1/2	D	8.8	7.4	8.6
3/4	D	9.0	7.7	9.1
1	E	10.4	8.8	10.6
1	F	11.2	9.7	11.4
1 1/4	G	10.9	9.3	11.1
1 1/4	F	12.0	10.3	12.2
1 1/4	E	13.8	12.2	14.0
1 1/2	E	11.1	9.4	11.4
1 1/2	F	11.9	10.4	12.2
1 1/2	G	14.0	12.4	14.3
1 1/2	H	15.1	13.5	15.4
2	E	11.9	10.1	12.0
2	F	12.6	10.9	12.8
2	G	14.8	14.6	15.0
2	H	15.7	14.0	15.9
2 1/2	F	13.7	11.4	?
2 1/2	G	15.7	13.4	?
2 1/2	H	16.8	14.5	?

Dimensions [inch]

Type 2030

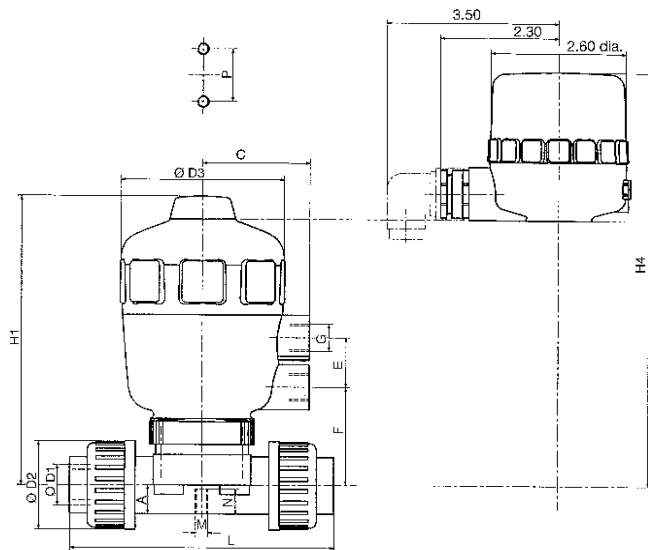

Type 2031

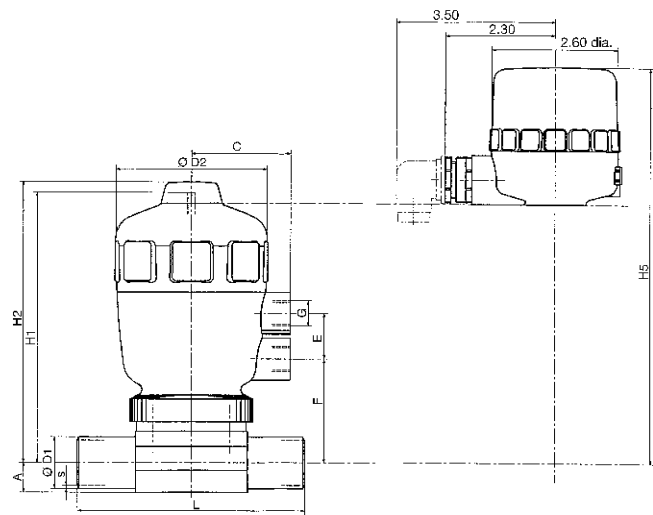

Specifications Type 2030

Valve Size [inch]	Actuator Size	H1	H4	D3
1/2	D	4.8	7.2	2.5
1/2	E	5.5	7.8	3.2
3/4	E	5.8	8.1	3.2
3/4	F	6.8	9.1	4.0
1	E	6.2	8.5	3.2
1	F	6.9	9.3	4.0
1 1/4	G	9.1	11.3	5.0
1 1/2	G	9.4	11.6	5.0
1 1/2	H	10.9	13.1	6.0
2	G	9.8	12.0	5.0
2	H	11.2	13.4	6.0

Specifications Type 2031

Valve Size	Actuator Size	H2	H5	D2
1/2	D	4.6	7.0	2.50
1/2	E	5.3	7.6	3.15
3/4	E	5.7	8.1	3.15
3/4	F	6.8	9.1	4.00
1	E	6.1	8.4	3.15
1	F	6.9	9.2	4.00
1 1/4	G	9.0	11.2	5.00
1 1/2	G	9.1	11.3	5.00
1 1/2	H	10.7	12.9	6.00
2	G	9.6	11.8	5.00
2	H	10.9	13.1	6.00
2 1/2	H	11.4	13.6	6.00



Advantages / Benefits

- ▶ Permits the use of stroke adjustment and manual override options
- ▶ Reliable switching function
- ▶ Space-saving design, simple installation
- ▶ LED-display
- ▶ Reverse polarity protection
- ▶ Short circuit-proof
- ▶ Pulsed PNP
- ▶ Protected against inductive spikes

Design

The magnetic-inductive sensors react to the approach of the magnetic piston of the series 2000-2031 piston-operated Y-pattern diaphragm valve. Thus, the piston position can be optically and electrically displayed with LED display.

- For actuator versions equipped with magnetic piston only.
- Permits the use of additional accessories: stroke limiters or manual override

Technical Data

Nominal field strength $I H_n I$	1.2 kA/m
Working field strength $I H_a I$	≥ 2 kA/m
Hysteresis	$\leq 45\%$ of H_n
Ambient temperature	-4°C to $+158^\circ\text{C}$
Temp.drift of switch-on point	$\leq 0.3\%/^\circ\text{C}$
Operating voltage U_B	10 to 30 V DC
Residual ripple	$\leq 15\%$
Max. power rating I_a	200 mA
Capacitive load	$\leq 1 \mu\text{F}$
Voltage drop U_d	≤ 2.5 V
Raise time	≤ 0.5 ms
Switch-off time	20 to 50 ms
Power consumption*)	$\leq 12/\leq 10$ mA
Housing material	PBTP (GF-reinforced)
Rating (DIN 40 050)	IP 67
Weight	2 oz.

*)damped/undamped

Consisting of Solenoid Piston, Sensor Fixation, Elbow Joint, Proximity Sensor – Dimensions [inch]

Sensor Type 1071 with plug connector, IP 67

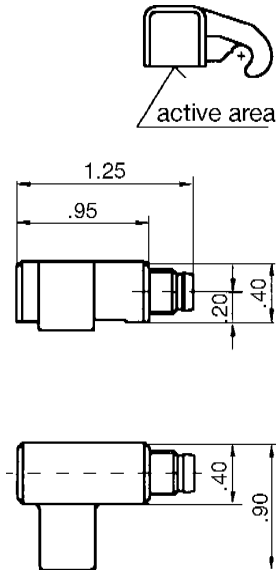

Plug connector, straight, without LED, cable 9.8 feet

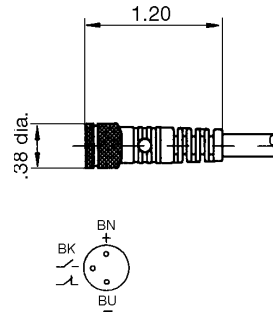

Elbow plug connector, with LED, cable 9.8 feet

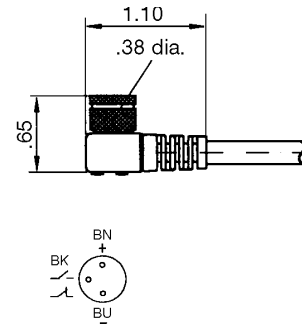

Installation

Sensor bracket, consisting of mounting bracket 1 and EJOT-PT-screw 2

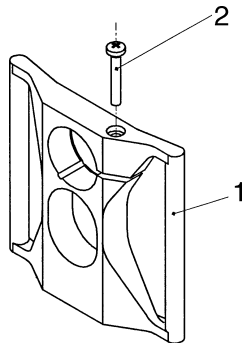

Mount sensor to elbow joint and sensor bracket

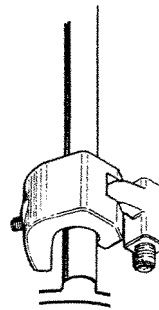

Elbow joint:

- 1 elbow joint
- 2 Cheesehead screw DIN 912-M4x12-A2
- 3 Pin DIN 913-M6x10-A2

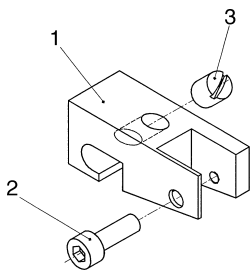

For ordering specifications of individual parts, please refer to spare parts list.



Advantages / Benefits

- ▶ For alarm and emergency devices, safety disconnect and sequencing
- ▶ Additional visual position indicator
- ▶ Simple installation
- ▶ Easy to retrofit
- ▶ Easily accessible internal components and terminals
- ▶ Compact NEMA 4 (IP65) enclosure

Technical Data

Microswitch	Normally opened or closed
Switching load	250 VDC Non-inductive or induct. load max. 5A, incandescent filament load 0.5A
	250 VDC Non-inductive load 0.25A inductive load 0.02A incandescent filament load 0.02A
Rating	NEMA 4 (IP 65)
Connection	Solder connections, cable entry sealed by gland with cable grip for 1/4-inch cable
Wiring diagram	1 Common terminal 2 Normally closed terminal 3 Normally open terminal

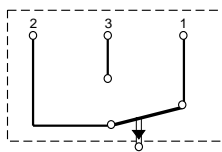

Dimensions [inch]

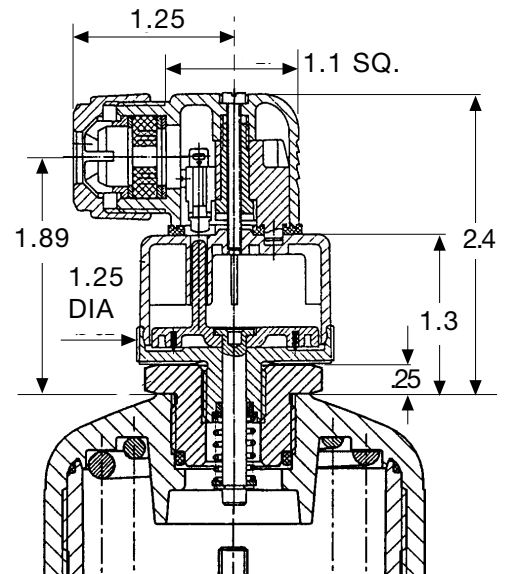

Max. Stroke Limiter*

Without Visual Position Indication



Advantages / Benefits

- ▶ Maximum stroke limiter
- ▶ Easy adjustment with Allen wrench
- ▶ Can be combined with external inductive position indication Type 1071

Dimensions [inch]

Actuator size D, E, F

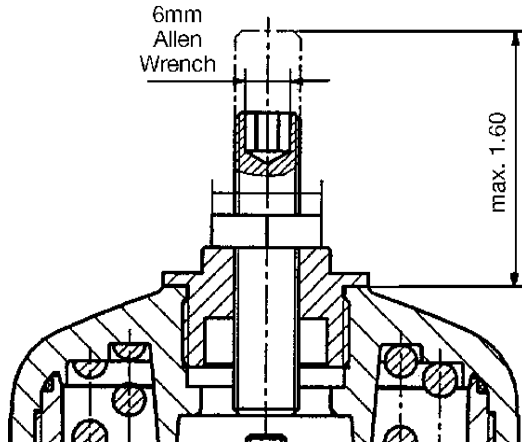

Actuator size G, H

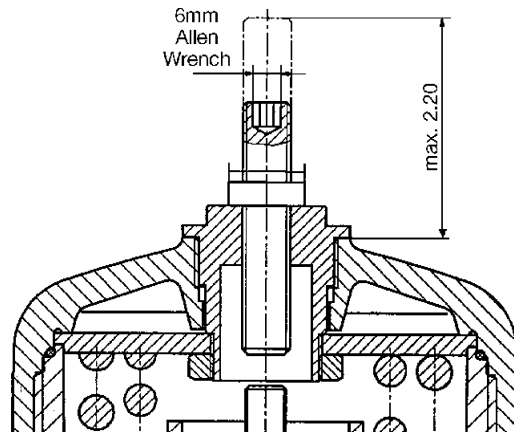

* Upper stroke limitation only
* Control function A only (normally closed)

Min./Max. Stroke Limiter

Without Visual Position Indication



Advantages / Benefits

- ▶ Maximum and minimum flow setting
- ▶ Integrated, clear visual position indication
- ▶ Easy to retrofit
- ▶ Upper and lower stops adjustable with standard screw driver
- ▶ May be used as manual override
- ▶ Can be combined with external inductive position indicator Type 1071
- ▶ Two versions available; (Actuator size D, E, F and Actuator size G, H)

Dimensions for Type 2000 [inch]

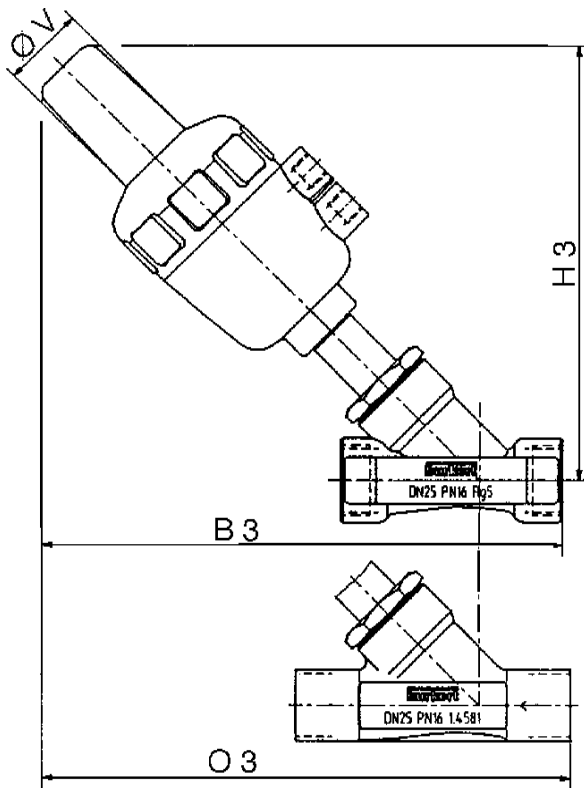

Specification

Valve Size	Actuator Size	B3	H3	O3	øV
1/2	D	8.3	6.9	8.3	1.5
3/4	D	8.5	7.2	8.6	1.5
1	E	9.7	8.1	9.9	1.5
1	F	10.3	8.8	10.5	1.5
1 1/4	E	10.2	8.7	10.4	1.5
1 1/4	F	11.1	9.4	11.3	1.5
1 1/4	G	13.6	12.0	13.7	2.1
1 1/2	E	10.4	8.8	10.7	1.5
1 1/2	F	10.9	9.5	11.3	1.5
1 1/2	G	13.7	12.1	14.1	2.1
1 1/2	H	14.6	13.0	14.9	2.1
2	E	11.2	9.4	11.4	1.5
2	F	11.7	10.0	11.9	1.5
2	G	14.6	13.6	14.8	2.1
2	H	15.2	13.5	15.4	2.1
2 1/2	F	12.8	10.5	-	1.5
2 1/2	G	15.4	14.0	-	1.5
2 1/2	H	16.3	14.0	-	2.1

Min./Max. Stroke Limiter

With Visual Position Indication

Dimensions [inch]

Type 2030

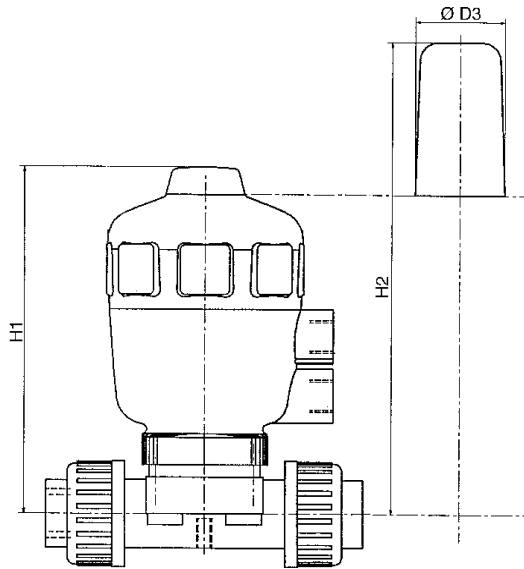

Type 2031

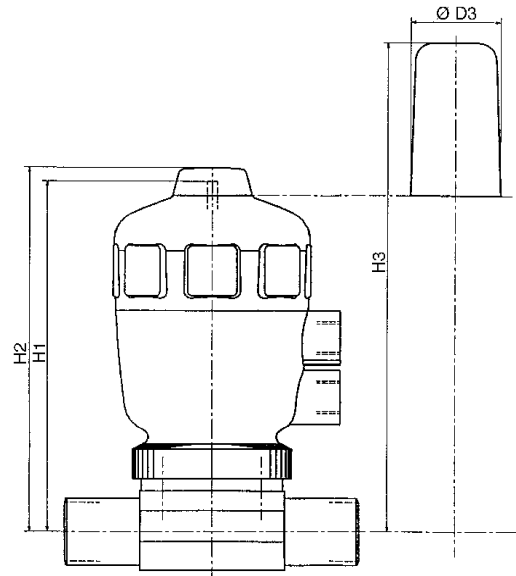

Specifications Type 2030

Valve Size	Actuator Size	H1	H2	D3
1/2	D	4.8	6.8	1.5
1/2	E	5.5	7.4	1.5
3/4	E	5.8	7.8	1.5
3/4	F	6.8	8.8	1.5
1	E	6.2	8.1	1.5
1	F	6.9	8.9	1.5
1 1/4	G	9.1	12.0	2.1
1 1/2	G	9.4	12.3	2.1
1 1/2	H	10.9	13.8	2.1
2	G	9.8	12.7	2.1
2	H	11.2	14.1	2.1

Specifications Type 2031

Valve Size	Actuator Size	H2	H3	D3
1/2	D	4.6	7.0	1.5
1/2	E	5.3	7.6	1.5
3/4	E	5.7	8.1	1.5
3/4	F	6.8	9.1	1.5
1	E	6.1	8.4	1.5
1	F	6.9	9.2	1.5
1 1/4	G	9.0	11.2	2.1
1 1/2	G	9.1	11.3	2.1
1 1/2	H	10.7	12.9	2.1
2	G	9.6	11.8	2.1
2	H	10.9	13.1	2.1
2 1/2	H	11.4	13.6	2.1

Manual Override

With Visual Position Indication



Advantages / Benefits

- ▶ For normally closed valves only
- ▶ Integrated visual position indicator
- ▶ Easy to retrofit
- ▶ May be combined with external inductive position indication Type 1071

Dimensions for Type 2000 [inch]

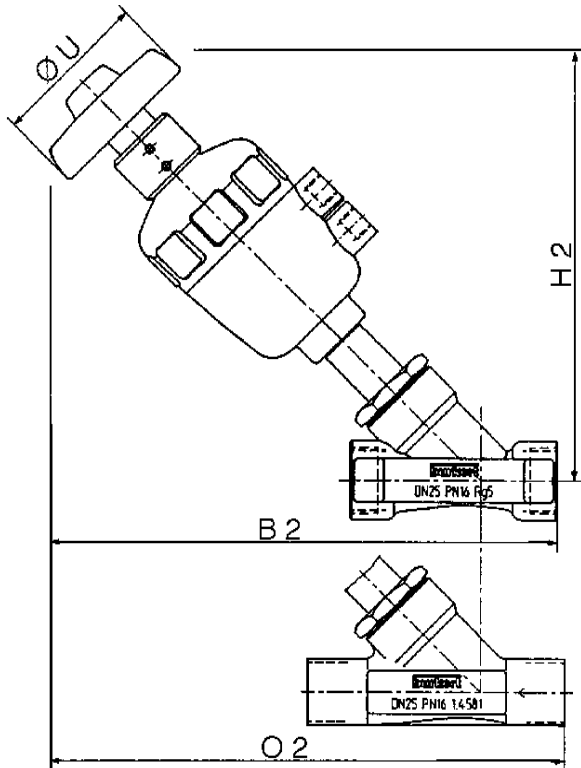

Specifications

Valve Size	Actuator Size	B2	H2	O2	øU
1/2	D	8.7	7.3	8.7	3.2
3/4	D	8.0	7.6	9.0	3.2
1	E	10.1	8.6	10.2	3.2
1	F	10.8	9.3	10.9	3.2
1 1/4	E	10.7	9.1	10.8	3.2
1 1/4	F	11.6	9.8	11.8	3.2
1 1/4	G	14.3	12.7	14.4	5.9
1 1/2	E	10.8	9.2	11.1	3.2
1 1/2	F	11.4	10.0	11.7	3.2
1 1/2	G	14.4	12.8	14.8	5.9
1 1/2	H	15.3	13.7	15.6	5.9
2	E	11.6	9.8	11.8	3.2
2	F	12.2	10.4	12.4	3.2
2	G	15.3	15.0	15.5	5.9
2	H	15.9	14.2	16.1	5.9
2 1/2	F	13.2	11.0	-	3.2
2 1/2	G	16.1	13.9	-	5.9
2 1/2	H	17.0	14.7	-	5.9

Manual Override

With Visual Position Indication

Dimensions [inch]

Type 2030

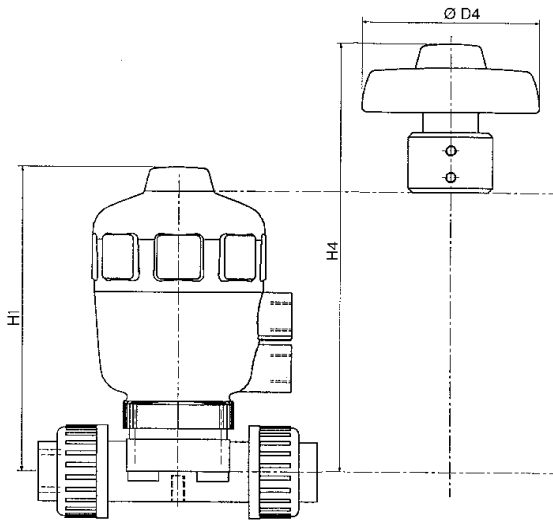

Type 2031

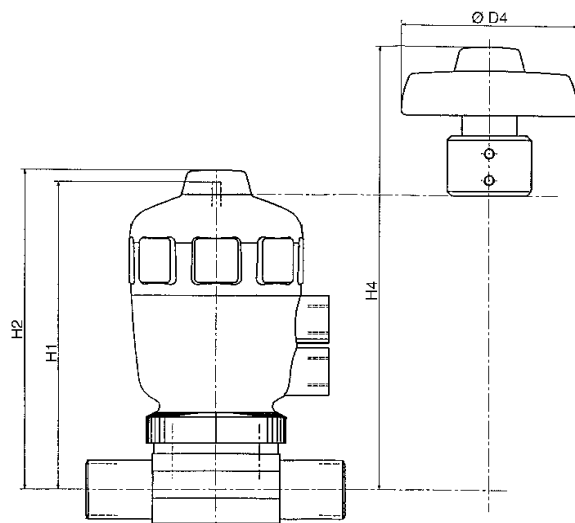

Specifications Type 2030

Valve Size	Actuator Size	H1	H4	D4
1/2	D	4.8	7.2	3.2
1/2	E	5.5	7.8	3.2
3/4	E	5.8	8.1	3.2
3/4	F	6.8	9.1	3.2
1	E	6.2	8.5	3.2
1	F	6.9	9.3	3.2
1 1/4	G	9.1	11.3	5.9
1 1/2	G	9.4	11.6	5.9
1 1/2	H	10.9	13.1	5.9
2	G	9.8	12.0	5.9
2	H	11.2	13.4	5.9

Specifications Type 2031

Valve Size	Actuator Size	H2	H4	D4
1/2	D	4.6	6.9	3.2
1/2	E	5.3	7.5	3.2
3/4	E	5.7	8.0	3.2
3/4	F	6.8	9.0	3.2
1	E	6.1	8.3	3.2
1	F	6.9	9.1	3.2
1 1/4	G	9.0	11.8	5.9
1 1/2	G	9.1	11.9	5.9
1 1/2	H	10.7	13.4	5.9
2	G	9.6	12.3	5.9
2	H	10.9	13.7	5.9
2 1/2	H	11.4	14.2	5.9

Namur-Adapter for Pilot Valves



Advantages / Benefits

- ▶ **Namur interface** allows easy installation of pilot valve to actuator
- ▶ **Increased operational reliability** when using the Burkert pilot valves Types 6519 and 5470.

Technical Data

Materials

- ① Plate and ② hollow screw Steel 1.4021 or CuZn39 Pb3 F44
- ③ O-rings DIN3771
16x2-N-NBR75

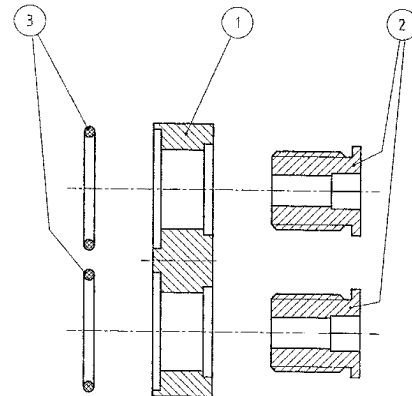

Dimensions [inch]

Adapter for actuators: D, E, F

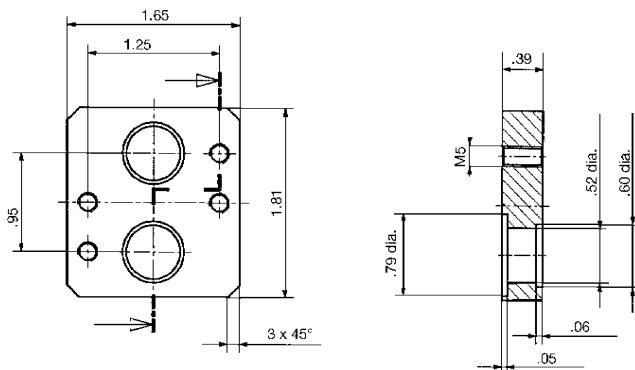

Adapter for actuators: G, H

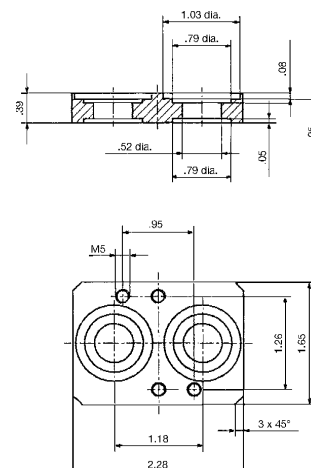

Hollow screw with hexagonal socket SW 6

Combination Options of Accessories

	Electrical position feedback Type 1062	External magnet inductive position feedback Type 1071	Electrical feedback signaller with optical position indication Type 1060	Max. stroke limitation	Min./max. stroke limitation	Manual override with opt. position indication	Namur-adapter for pilot valves
Electrical position feedback Type 1062		and	or	or	or	or	and
External magnet inductive position feedback Type 1071	and		and	and	and	and	and
Electrical feedback signaller with optical position indication Type 1060	or	and		or	or	or	and
Max. stroke limitation	or	and	or		or	or	and
Min./max. stroke limitation	or	and	or	or		or	and
Manual override with opt. position indication	or	and	or	or	or		and
Namur-adapter for pilot valves	and	and	and	and	and	and	

Electrical Position Feedback Type 1062 - Ordering Chart

With mechanical limit switches:

Actuator Size	Indicated Valve Position	Item No.	
		110V - 250V AC/DC	12V - 48V AC/DC
D, E, F	OPEN	005415K	007462U
	CLOSED	005409E	007461T
	OPEN/CLOSED	005416L	007463V
G, H	OPEN	007459H	007465X
	CLOSED	007458G	007464W
	OPEN/CLOSED	007460E	007466Y

Note: Voltage ranges 48-110 VAC/DC available on request.

With inductive limit switches:

Actuator Size	Indicated Valve Position	Item No.	
		Standard Inductive 10-30 VDC	NAMUR Exi 8 VDC
D, E, F	OPEN	005434N	007471V
	CLOSED	005422J	007470G
	OPEN/CLOSED	005461Z	007472W
G, H	OPEN	007468A	007473X
	CLOSED	007467Z	007474Y
	OPEN/CLOSED	007469B	007475Z

Specification Tag	Item No.	633529W
-------------------	----------	---------

External Magnet Inductive Position Feedback Type 1071 - Ordering Chart

Magnetic piston

Actuator Size	Item No.
D	630063F ¹⁾
E	630064G
F	630065H
G	630066A
H	630067B

¹⁾ For Types 2000/2001 only

Sensor

Type	Style	Item No.
1071	Plug Connector	780110E
1071	With Cable (No LED)	780111T

Sensor mounting bracket

Actuator Size	Item No.
D	636239E ¹⁾
E-H	636239E

¹⁾ For Types 2000/2001 only

Plug Connector

Style	Item No.
Elbow Plug, Cable 10 ft.	780112U
Straight Plug Connector, No LED	780113V

Elbow joint

Material	Item No.
Diecast	780558K
Stainless Steel	636241G

Ordering Chart - Accessories

Min./max. stroke limitation with visual position indication

Actuator Size	Item No.
D	636820Z
E	636820Z
F	636820Z
G	636821N
H	640703Y

Electrical feedback switch Type 1060 with installation nipple

Actuator Size	Item No.
D	701515V
E	701515V
F	701515V
G	701516W
H	701516W

Max. stroke limitation without visual position indication

Actuator Size	Item No.
D	637866U
E	637866U
F	637866U
G	637867V
H	637868E

Manual override with visual position indicator (Normally closed function only)

Actuator Size	Item No.
D	636822P
E	636822P
F	636822P
G	636823Q
H	636823Q

Namur-adapter, all brass

Actuator Size	Item No.
D	637113R ¹⁾
E	637113R
F	637113R
G	637114J
H	637114J

Namur-adapter, all stainless steel

Actuator Size	Item No.
D	632974T ¹⁾
E	632974T
F	632974T
G	634275G
H	634275G

1) For Y--attern Valve Type 2000/2001/2002 only.