

2/2-Way; DN 8-50 mm



Advantages / Benefits

- ▶ Hermetic isolation of fluid from the atmosphere
- ▶ Higher flow than conventional diaphragm valves
- ▶ Zero dead volume
- ▶ Corrosion resistant
- ▶ Long service life even with polluted "dirty" or high viscosity fluids
- ▶ Self-draining when installed appropriately

Design

This diaphragm valve with stainless steel body is an alternative to ball valves for polluted, dirty, abrasive or high viscosity fluids.

High flow rates are attained with the 2-way unique stainless steel body.

The diaphragm between the actuator and body hermetically isolates the fluid from the actuator.

The maintenance-free and robust valves can be retro-fitted with a comprehensive range of accessories for position indication, stroke limitation or hand wheel operation.

Applications

- Pollution control equipment
- Chemical processing equipment
- Cosmetic processing equipment
- Food processing equipment
- Bottling systems
- Water treatment
- Textile dyeing
- Paint Spraying equipment

bürkert
Easy Fluid Control Systems

Technical Data

Control Functions

A 2/2-way valve,
normally closed by spring action.

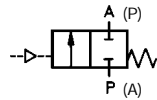

I 2/2-way valve, with double-
acting actuator.

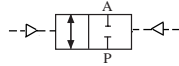

Specifications

Orifice [mm]	Kv-Value [m³/h]	Operating Pressure		Actuator Size [ø mm]	Weight [kg]
		Diaphragm EPDM [bar]	PTFE [bar]		
8	1.77	10.0	9	40	0.39
15	5.40	7.0	-	50	0.69
		10.0	8.5	63	1.00
20	13.90	7.5	-	63	1.30
		10.0	10	80	2.00
25	22.60	5.0	-	63	1.30
		10.0	7	80	2.17
32	33.50	10.0	8	100	3.90
40	43.30	7.0	-	100	4.16
		10.0	10	125	5.80
50	74.30	8.5	7	125	7.60

Operating Data (Valve)

Fluid temperature -10 °C to +140 °C
depending on
diaphragm material

Valve body 1.4404 Stainless steel
Body surfaces: Internally Ra 1,0...Ra 2,2

Diaphragm material EPDM, PTFE

On request

- Flanged connection
- Tri-Clamp
- Digital electropneumatically operated positioner

Operating Data (Actuator)

Material PA (Threaded port version)
PPS (Weld-end version)

Ambient temperature PA -10°C to + 60°C
PPS +5°C to +140°C

Control Pressure

Max. admissible control pressure 10 bar (PA)
7 bar (PPS)

Circuit function A (spring to close):

Min. required control pressure 5,5 bar

Circuit function I (no spring):

The following max. control pressures are required to provide max. operating pressure: 6 bar

Control fluid neutral gases, air

Diaphragm valve with stainless steel body

Type 2031

General Purpose

Materials

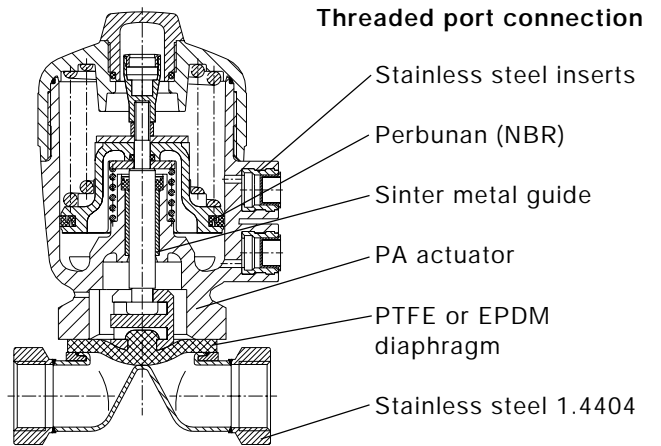
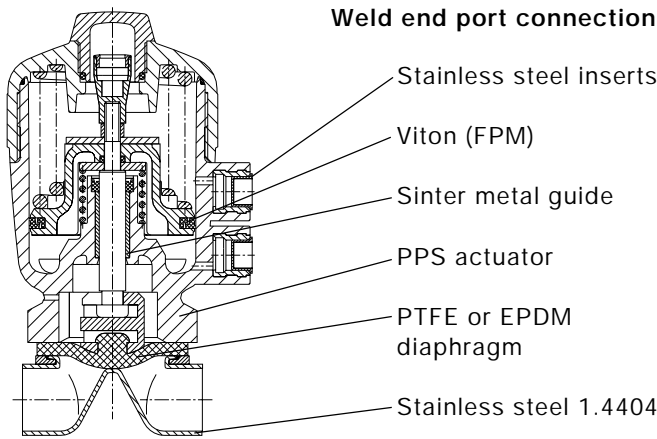

Dimensions [mm]

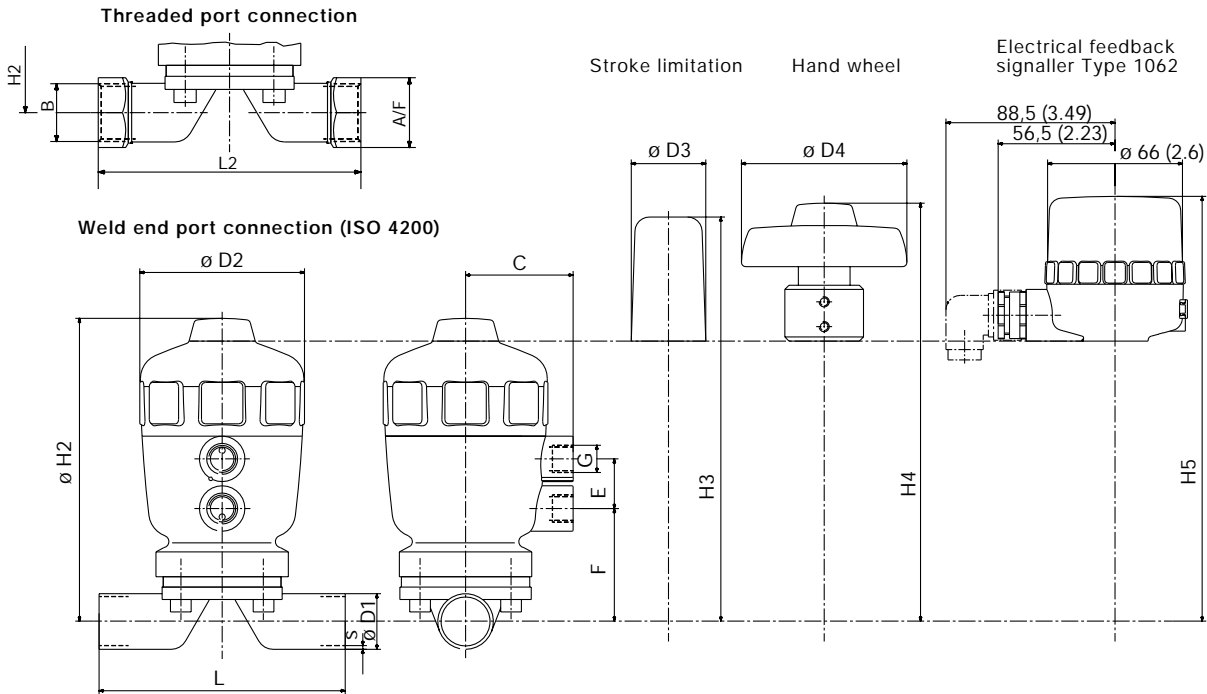

Orifice	Actuator	B	C	D1	ø D2	ø D3	ø D4	E	F	G	H2	H3	H4	H5	L	L2	A/F	S
[mm]	[mm]																	
8	40	G 1/4	34	13.5	53	-	-	16.5	29	G 1/8	85	-	-	-	90	85	17	1.6
15	50	G 1/2	39	21.3	64	39	80	20	44	G 1/8	122	172	178	181	110	102	27	1.6
15	63	G 1/2	52	21.3	80	39	80	24	43	G 1/4	139	189	195	198	110	102	27	1.6
20	63	G 3/4	52	26.9	80	39	80	24	54	G 1/4	146	198	204	207	119	118	32	1.6
20	80	G 3/4	60	26.9	101	39	80	24	62	G 1/4	174	224	230	233	119	118	32	1.6
25	80	G1	60	33.7	101	39	80	24	65	G 1/4	177	227	233	236	129	127	41	2.0
32	100	G11/4	73	42.4	127	53	150	24	81	G 1/4	230	303	300	286	148	146	50	2.0
40	100	G11/2	73	48.3	127	53	150	24	85	G 1/4	235	308	305	291	161	159	60	2.0
40	125	G11/2	86	48.3	153	53	150	30	93	G 1/4	274	347	344	330	161	159	60	2.0
50	125	G2	86	60.3	153	53	150	30	99	G 1/4	278	351	348	334	192	191	70	2.0

Ordering Chart (Other Versions on Request)

Control Function A, normally closed by spring, G-port connection, PA-actuator

Port connect.	Orifice [mm]	Diaphragm	Operating pressure [bar]	Actuator Size [mm]	Order-No.
G 1/4	8	EPDM	10.0	40	135 443 M
G 1/4	8	PTFE/EPDM	9.0	40	135 447 R
G 1/2	15	EPDM	7.0	50	135 460 S
G 1/2	15	EPDM	10.0	63	135 467 M
G 1/2	15	PTFE/EPDM	8.5	63	135 473 K
G 3/4	20	EPDM	7.5	63	135 482 D
G 3/4	20	EPDM	10.0	80	135 490 R
G 3/4	20	PTFE/EPDM	10.0	80	135 492 F
G1	25	EPDM	5.0	63	135 504 K
G 1	25	EPDM	10.0	80	135 512 A
G 1	25	PTFE/EPDM	7.0	80	135 514 C
G 11/4	32	EPDM	10.0	100	135 526 G
G 11/4	32	PTFE/EPDM	8.0	100	135 541 P
G 11/2	40	EPDM	7.0	100	135 549 X
G 11/2	40	EPDM	10.0	125	135 556 N
G 11/2	40	PTFE/EPDM	10.0	125	135 571 M
G 2	50	EPDM	8.5	125	135 586 D
G 2	50	PTFE/EPDM	7.0	125	135 593 C

Control Function A, normally closed by spring, Weld-end port connection (ISO 4200), PPS-actuator

Port connect.	Orifice [mm]	Diaphragm	Operating pressure [bar]	Actuator Size [mm]	Order-No.
Weld end	8	EPDM	10.0	40	135 442 L
Weld end	8	PTFE/EPDM	9.0	40	135 446 Q
Weld end	15	EPDM	7.0	50	135 459 V
Weld end	15	EPDM	10.0	63	134 305 S
Weld end	15	PTFE/EPDM	8.5	63	134 311 P
Weld end	20	EPDM	7.5	63	135 481 C
Weld end	20	EPDM	10.0	80	134 306 T
Weld end	20	PTFE/EPDM	10.0	80	134 312 Q
Weld end	25	EPDM	5.0	63	135 503 J
Weld end	25	EPDM	10.0	80	134 307 U
Weld end	25	PTFE/EPDM	7.0	80	134 313 R
Weld end	32	EPDM	10.0	100	134 308 D
Weld end	32	PTFE/EPDM	8.0	100	134 314 J
Weld end	40	EPDM	7.0	100	135 548 W
Weld end	40	EPDM	10.0	125	134 309 E
Weld end	40	PTFE/EPDM	10.0	125	134 315 K
Weld end	50	EPDM	8.5	125	134 310 S
Weld end	50	PTFE/EPDM	7.0	125	134 316 L

Control Function I, double-acting actuator, G-port connection, PA-actuator

Port connect.	Orifice [mm]	Diaphragm	Operating pressure [bar]	Actuator Size [mm]	Order-No.
G 1/4	8	EPDM	10.0	40	135 676 W
G 1/4	8	PTFE/EPDM	10.0	40	135 677 X
G 1/2	15	EPDM	10.0	50	135 680 X
G 1/2	15	PTFE/EPDM	9.5	63	135 684 P
G 3/4	20	EPDM	8.5	63	135 688 T
G 3/4	20	EPDM	10.0	80	135 694 R
G 3/4	20	PTFE/EPDM	10.0	80	135 696 K
G 1	25	EPDM	10.0	80	135 702 Z
G 1	25	PTFE/EPDM	9.0	80	135 704 T
G 11/4	32	EPDM	10.0	100	135 708 F
G 11/4	32	PTFE/EPDM	9.0	100	135 712 J
G 11/2	40	EPDM	10.0	100	135 716 N
G 11/2	40	PTFE/EPDM	10.0	125	135 720 W
G 2	50	EPDM	10.0	125	135 724 N
G 2	50	PTFE/EPDM	9.5	125	135 728 S

Control Function I, double-acting actuator, Weld-end port connection (ISO 4200), PPS-actuator

Port connect.	Orifice [mm]	Diaphragm	Operating pressure [bar]	Actuator Size [mm]	Order-No.
Weld end	8	EPDM	10.0	40	135 674 U
Weld end	8	PTFE/EPDM	10.0	40	135 675 V
Weld end	15	EPDM	10.0	50	135 679 H
Weld end	15	PTFE/EPDM	9.5	63	135 683 N
Weld end	20	EPDM	8.5	63	135 687 J
Weld end	20	EPDM	10.0	80	135 691 N
Weld end	20	PTFE/EPDM	10.0	80	135 693 Q
Weld end	25	EPDM	10.0	80	135 699 W
Weld end	25	PTFE/EPDM	9.0	80	135 701 Y
Weld end	32	EPDM	10.0	100	135 707 W
Weld end	32	PTFE/EPDM	9.0	100	135 711 R
Weld end	40	EPDM	10.0	100	135 715 M
Weld end	40	PTFE/EPDM	10.0	125	135 719 Z
Weld end	50	EPDM	10.0	125	135 723 M
Weld end	50	PTFE/EPDM	9.5	125	135 727 R

Accessories and Options on Request

- Digital electro-pneumatically operated positioner
- Electrical feedback signaller Type 1062
- Magnetic-inductive proximity sensors for position sensing mounted to the actuator
- Independently adjustable stroke limitation:
 - for maximum flow
 - for minimum flow
- Hand wheel
- Namur adapter for pilot valve

