

OGDEN INSTRUCTION MANUAL

ETR-3 FM SUB-PANEL MOUNT HI-LIMIT CONTROL

The ETR-3 Series is designed for industrial and commercial applications which require high temperature protection. These controls feature a latching, manually resettable relay output which de-energizes whenever the sensed temperature exceeds the set point temperature. It can also be configured as an on-off temperature control.

SPECIFICATIONS

Power Input: 120VAC $\pm 15\%$, 50/60Hz, 3VA max. standard (240VAC and other AC/DC voltages optional).

Control Output: SPDT Relay rated 3.8 (1.5) Amps Res. and 1.5 (.8) Amps Pilot Duty 120 (240)VAC. 100,000 cycles. Optional DC output to drive SSR.

Control Mode: Latching with Manual Reset or power off.

Reset Function: Integral reset switch standard; terminals available for optional remote reset switch.

Set Point Adjustment: Local SP dial adjustment.

Compensation (TC only): Automatic cold junction compensation.

Control Stability: Typically less than $\pm 5\mu V/^\circ F$ ambient and 0.1% of SPAN/% rated line voltage.

Set Point Accuracy: $\pm 3\%$ of FS maximum at 78°F (25°C) and rated line voltage.



Sensor Break Protection: Contacts 4 and 5 open for thermocouple or RTD break.

Ambient Operating Temperature: 32 - 140°F (0 - 60°C).

MECHANICAL

Enclosure Material: Noryl, Black color.

Field Terminations: Screw Terminals with wire clamping plates and touch safe shield.

Mounting: 35mm DIN rail or surface mounting.

AGENCY APPROVALS: UL 873 and CUL per CSA C22.2 No.24 File #E179225; FM 3545.

MOUNTING

The ETR-3 can be surface mounted or mounted on a DIN rail. The ETR-3 must be located inside a suitable control enclosure. It can be mounted to any suitable flat surface using two #8 screws (not supplied). To install simply position the top set of rear clips over the top of the DIN

rail. Then swing the bottom of the controller toward the rail applying pressure until the lower clips snap on to the bottom of the DIN rail. To remove apply pressure to the top of the controller's base and move the bottom of the controller toward you. Then lift the top of the controller off the upper DIN rail.

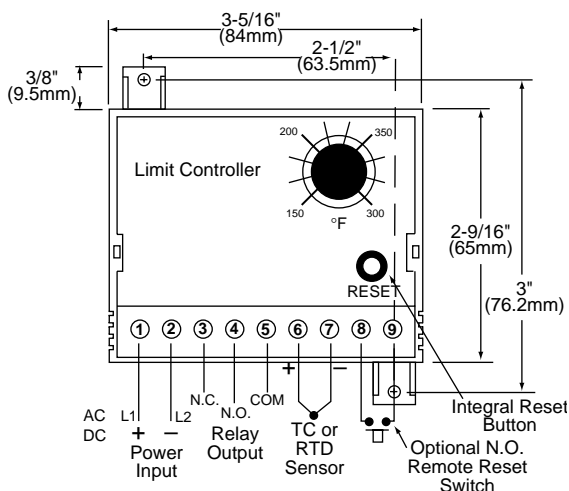

DIMENSIONS:

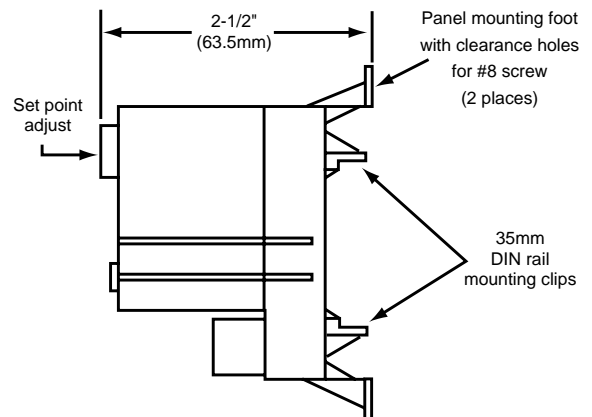

TYPICAL WIRING DIAGRAM

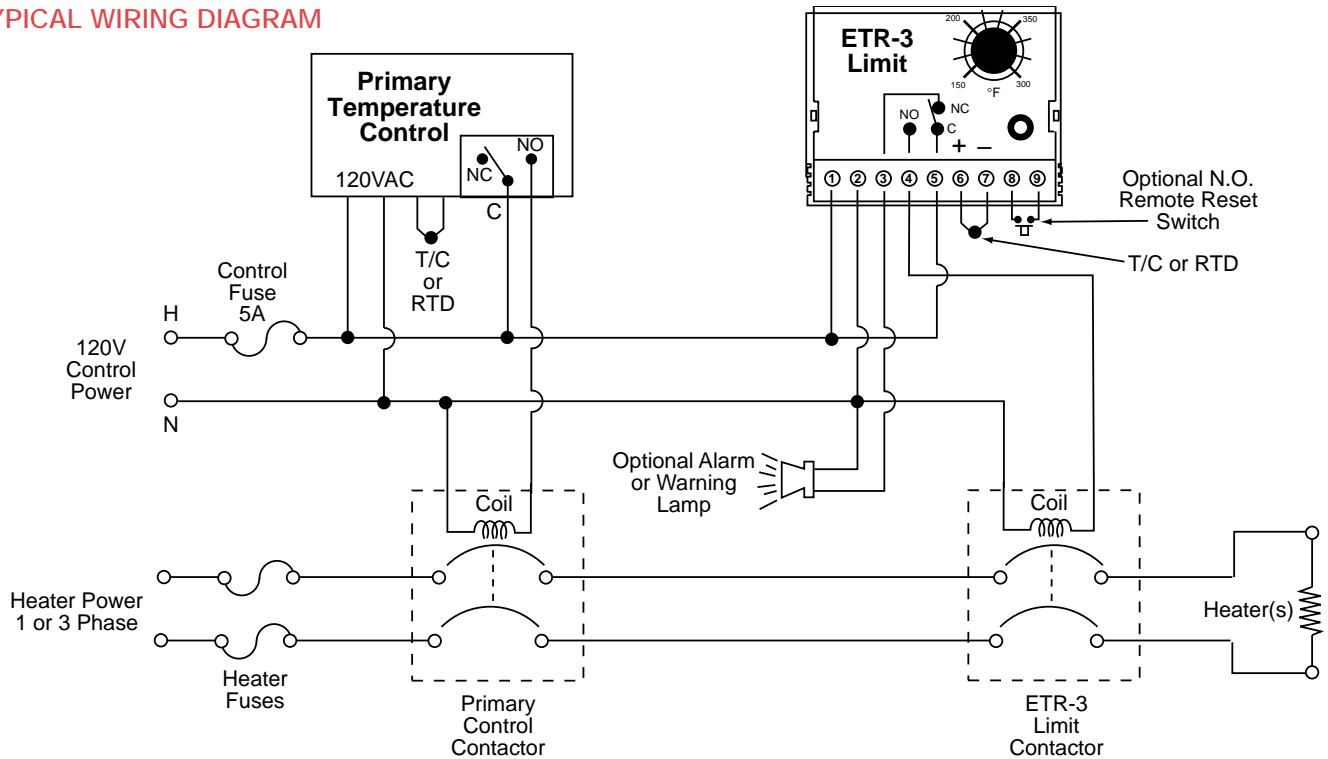

WIRING

Carefully follow the terminal diagram pictured on the controller's housing and shown above. The power and load wiring should be 18 AWG or larger size. Be sure to observe that the ratings for voltage and current are not exceeded. All local and national electrical codes must be followed. Use only the sensor type as indicated on the control and maintain correct polarity. **THE RED THERMOCOUPLE LEAD ALWAYS CONNECTS TO THE NEGATIVE (-) TERMINAL.**

To reduce electrical noise, the thermocouple wire must be isolated from any power or heater wiring. Shielded thermocouple wire may be necessary in high noise environments or when lead lengths exceed 10 feet. Thermocouples are tip sensitive and must be in good mechanical contact with the load.

OPERATION

The set point temperature is adjustable by turning the integral dial. If the set point is exceeded, contacts 4 and 5 will open. It will remain in this state until the temperature drops below the set point and the controller is manually reset. Manual reset can be accomplished by one of the following means: a) Press the "reset button". b) A momentary switch closure between terminals 8 and 9. c) Interrupt power to the control.

CAUTION

This controller must be mounted in an enclosure suitable for protection against normally expected operation environments and to minimize unauthorized tampering with the limit settings. This control is not to be used in hazardous locations as defined in Articles 500 and 505 of the National Electric Code.

MAINTENANCE

No specific maintenance is required. However, it is recommended that all wiring be checked periodically for loose connections and damaged wires. Disconnect power to the panel before any maintenance is performed. Check wires and tighten connections.

TROUBLE SHOOTING

RISK OF ELECTRIC SHOCK - Dangerous and potentially fatal voltages are present when working on this equipment. Before installation or beginning any troubleshooting procedures, the electric power to this equipment must be disconnected and locked out as described by OSHA Standards. Units suspected of being faulty must be removed and returned to Ogden for inspection and/or repair. They contain no user serviceable components.

Experience has proven that many control problems are not caused by a defective instrument.

Some of the common causes of failure are broken sensors, open fuses and poor wire connections.

If these points have been checked and the control still does not function, it is suggested that the instrument be returned for inspection.

Use adequate packing materials to prevent damage in shipment.

Return Control To:
OGDEN MANUFACTURING CO.
 ATTN: Repair Department
 64 West Seegers Road, Arlington Heights, IL 60005



(847) 593-8050 • Fax: (847) 593-8062
 www.ogdenmfg.com

OGDEN and ETR are Registered
 Trademarks of
 Ogden Manufacturing Co.
 MARCA REGISTRADA