



MANUAL NO. 20
SOFTWARE VERSION
3.3 AND HIGHER

Model ETR-8120 and ETR-8130 Microprocessor Based SMARTER LOGIC[®] Temperature Control



INSTRUCTION MANUAL

INSTRUCTION MANUAL FOR ETR-8120 and ETR-8130

Section 1: INTRODUCTION

This manual contains information for the installation and operation of the **Ogden** Model ETR-8120 and ETR-8130 auto-tuning micro-processor based controller with Smarter Logic[®]. The ETR-8120 has one control output and the ETR-8130 has two control outputs for heating and cooling. Both models are available with (2) optional auxiliary outputs for use as alarms or other functions.

Ease of use is an essential feature on this versatile controller. Four touch keys are used to select sensor type, control mode, control parameters, alarm mode, degrees C/F, auto-manual mode, and to lock the parameters from the prevention of unauthorized tampering. Two large 4-digit displays show process and set point values at a glance. Precise 14 slope sensor linearization, self-diagnostic capability, cold junction compensation and 3-mode PID calculations are automatically exe-

cuted by the single chip microprocessor. The wide selection of parameters, values, sensor types, set points, control modes, alarm modes, degrees C/F and security codes are held in a non-volatile memory and retained for ten years if the unit is left unpowered. Batteries are not necessary.

The auto-tuning function determines the correct proportional band, rate and reset values to provide accurate control with minimal overshoot and temperature oscillation. This is accomplished without the need for expensive and time consuming procedures for set-up of control parameters. In case of a power failure or temporary shutdown, the instrument retains the correct parameters. This instrument also has manual override capabilities that allow the operator to bypass the auto-tuning parameters. Required fine tuning adjustments can then be made.

WARNING!

Failure of devices, such as the thermocouple-RTD sensor, heater output relay or temperature control can result in severe damage to a product while in process, melting of the heater or a damaging fire. An over-temperature protection device must be installed in your process that will remove all power from the heating circuit if the above failure occurs. We recommend that this device be classified as a safety control and carry FM, U.L. and CSA Listing or Certification. Failure to install high-limit temperature control protection where a potential hazard exists, could result in damage to equipment and property, and severe injury to personnel.



64 West Seegers Road
Arlington Heights, IL 60005
(847) 593-8050 • Fax: (847) 593-8062
www.ogdenmfg.com • www.sales@ogdenmfg.com

© Ogden Manufacturing Co. 1999
OGDEN, ETR and Smarter Logic are
Registered Trademarks of
Ogden Manufacturing Co.
MARCA REGISTRADA

Section 2: CATALOG NUMBERING SYSTEM

ETR-8120-

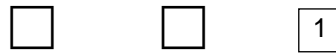
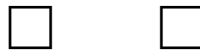

Power Input

- 3 90-264VAC, 50/60Hz
- 4 20-32VAC or VDC

Signal Input

- 1 Thermocouple J, K, T, E, B, R, S, N
- 2 RTD PT100 ohms, Alpha = 0.00385/DIN 43760
- 3 RTD PT100 ohms, Alpha = 0.00392/JIS
- 4 Voltage -10-60mV or other current or voltage (specify range)

Control Output

- 1 None
- 2 Relay rated 3A/240VAC resistive
- 3 Pulsed voltage to drive SSR, 3-32VDC
- 5 Isolated 4-20mA linear
- 6 Isolated 0-20mA linear
- 7 Isolated 0-10VDC linear
- 8 Special order

Alarm Outputs

- 1 None
- 2 With alarms A1 and A2, relays rated 2A/240VAC resistive
- 3 Special order

Example:

ETR-8120-31521

- 90-264VAC operating voltage
- Thermocouple input
- 4-20mA output
- With alarm option

ETR-8130-



Power Input

- 3 90-264VAC, 50/60Hz
- 4 20-32VAC or VDC

Signal Input

- 1 Thermocouple J, K, T, E, B, R, S, N
- 2 RTD PT100 ohms, DIN
- 3 RTD PT100 ohms, JIS
- 4 Voltage -10-60mV or other current or voltage (specify range)

Cooling Control Output

- 1 None
- 2 Relay rated 3A/240VAC
- 3 Pulsed voltage to drive SSR, 3-32VDC
- 5 Isolated 4-20mA linear
- 6 Isolated 0-20mA linear
- 7 Isolated 0-10VDC linear
- 8 Special order

Alarm Outputs

- 1 None
- 2 With alarms A1 and A2, relays rated 2A/240VAC resistive
- 3 Special Order

Heating Control Output

- 1 None
- 2 Relay rated 3A/240VAC
- 3 Pulsed voltage to drive SSR, 3-32VDC
- 5 Isolated 4-20mA linear
- 6 Isolated 0-20mA linear
- 7 Isolated 0-10VDC linear
- 8 Special order

Example:

ETR-8130-322221

- 90-264VAC operating voltage
- RTD input
- Relay output-heating
- Relay output-cooling
- With alarm option

Section 3: SPECIFICATIONS

Line Voltage:	90-264VAC, 50-60Hz, 20-32VAC/DC available on special order	Thermocouple break Protection:	Operator selectable
Input:	Type: J, K, R, T, B, E, S, N thermocouple, PT100 ohm RTD (DIN) 43760/BS1904 (JIS) and -10 to 60mV (given span).	Display:	Process ½" red LED Set point ⅜" green LED
Power consumption:	Less than 5VA.	Display update rate:	4 repeats per second
Accuracy:	±.1%, ± least significant digit.	°F/°C:	External keypad selectable
Operating ambient for rated accuracy:	14-120°F (-10 to 50°C)	Auto/Manual operation:	External keypad selectable
Storage Temperature:	-4 to 160°F (-20 to 70°C)	Linearization:	Software driven
Humidity:	0 to 90%RH (non-condensing)	Outputs:	Heating (and cooling) or alarms
Dimensions:	Front panel: H - 3¼" (96mm) W - 1⅞" (48mm) D - 3⅞" (79mm) Depth behind panel: 2⅞" (65mm)	Output modules	
Panel cutout:	1 ²⁵ / ₃₂ " x 3 ⁵ / ₈ " (45 x 92mm)	-Current output:	4-20mA isolated, max. load 500 ohms
Weight:	18 oz. (227 grams)	-Voltage output:	0-10V isolated, minimum impedance 500K ohms
Normal mode rejection:	60dB	-Pulsed voltage:	24VDC, unisolated max. current 20mA
Common mode rejection:	120dB	-Relay:	3A/240V, Resistive load for heating, 2A/240V, Resistive load for alarm.
		Control Action:	Heating (relay closed on temperature rise) or cooling (relay open on temperature rise) front panel selectable.

Maximum Temperature Ranges:

Sensor	Input Type	Max. Range F°	Sensor Accuracy F°	Max. Range C°	Sensor Accuracy C°
J	Iron/Constantan	-58 to 1832°F	±3.6°F	-50 to 1000°C	±2°C
K	Chromel/Alumel	-58 to 2500°F	±3.6°F	-50 to 1370°C	±2°C
T	Copper/Constantan	-454 to 752°F	±3.6°F	-270 to 400°C	±2°C
E	Chromel/Constantan	-58 to 1382°F	±3.6°F	-50 to 750°C	±2°C
B	Pt-30%RH/Pt-6%RH	32 to 3272°F	±5.4°F	0 to 1800°C	±3°C
R	Pt-13%RH/Pt	32 to 3182°F	±3.6°F	0 to 1750°C	±2°C
S	Pt-10%RH/Pt	32 to 3182°F	±3.6°F	0 to 1750°C	±2°C
N	Nicrosil/Nisil	-58 to 2372°F	±3.6°F	-50 to 1300°C	±2°C
RTD	PT 100 ohms (DIN)	-328 to 752°F	±0.72°F	-200 to 400°C	±0.4°C
RTD	PT 100 ohms (JIS)	-328 to 752°F	±0.72°F	-200 to 400°C	±0.4°C
Linear	Voltage or Current	-1999 to 9999	±0.05%	-1999 to 9999	±0.05%

Chromel® and Alumel® are Registered Trademarks of Hoskins Manufacturing Company.

Section 4: INSTALLATION

WARNING!



RISK OF ELECTRIC SHOCK - Dangerous and potentially fatal voltages are present when working on this equipment. Before installation or beginning any troubleshooting procedures, the electric power to this equipment must be disconnected and locked out as described by OSHA Standards. Units suspected of being faulty must be removed and returned to Ogden for inspection and/or repair. They contain no user serviceable components.

WARNING!



To help minimize the possibility of fire or shock hazards, do not expose this instrument to rain or excessive moisture. This control is not to be used in hazardous locations as defined in Articles 500 and 505 of the National Electric Code.

CAUTION!



Do not use this instrument in areas subject to hazardous conditions such as excessive shock, vibration, dirt, moisture, corrosive gases or oil. The ambient temperature of the areas should not exceed the maximum rating specified in Section 3, on previous page.

Unpacking:

Upon receipt of the shipment remove the instrument from the carton and inspect the unit for shipping damage. If any damage due to transit is noticed, report and file a claim with the carrier. Write down the model number, serial number, and date code for future reference when corresponding with our service center. The serial number (S/N) and date code (D/C) are located inside the control.

Mounting:

Make panel cutout to dimensions shown below right. Insert the controller into the panel cutout. The maximum panel thickness is 1/8" (3.2mm).

Wiring Precautions:

- Before wiring, verify the label for correct model number and options. Switch off the power when checking.
- Care must be taken to ensure that maximum voltage ratings specified in Section 3 on previous page are not exceeded.
- It is recommended that power to these instruments be protected by fuses and circuit breakers rated at the minimum value possible.
- All units should be installed inside a suitably grounded metal enclosure to prevent live parts being accessible to human hands and metal tools.
- All wiring must conform to appropriate standards of good practice, national and local codes and regulations. Wiring must be suitable for the maximum voltage, current, and temperature ratings expected in the system.
- Both solderless terminals or "stripped" leads as specified in Figure 4.1 below can be used for power leads. Only "stripped" leads should be used for thermocouple connections to prevent compensation and resistance errors.
- Take care not to over-tighten the terminal screws.
- Unused control terminals should not be used as jumper points as they may be internally connected, causing damage to the unit.
- Verify that the ratings of the output devices and the inputs as specified in Section 3 are not exceeded.
- Electric power in industrial environments contains a certain amount of noise in the form of transient voltages and spikes. This electrical noise can enter and adversely affect the operation of microprocessor-based controls. For this reason we strongly recommend the use of shielded thermocouple extension wire which connects from the sensor to the controller. This wire is a twisted-pair construction with foil wrap and drain wire. The drain wire is to be attached to earth ground at the sensor end only. We carry both type J and type K in our stock.

NOTE: The use of motor starters in place of magnetic contactors should be avoided. They have very large inductive loads that can damage the controller's relay.

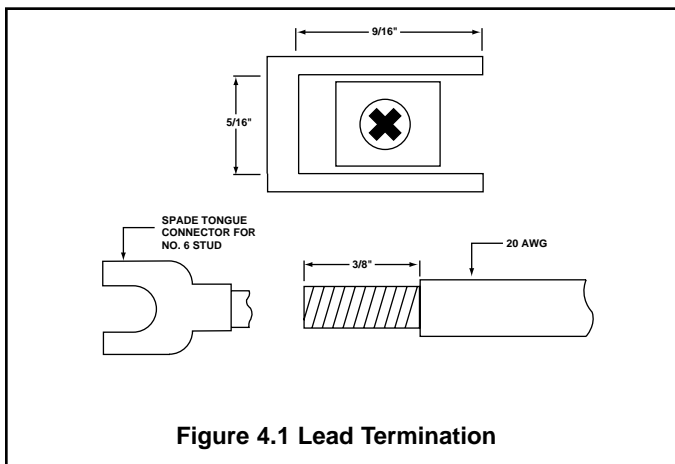

Figure 4.1 Lead Termination

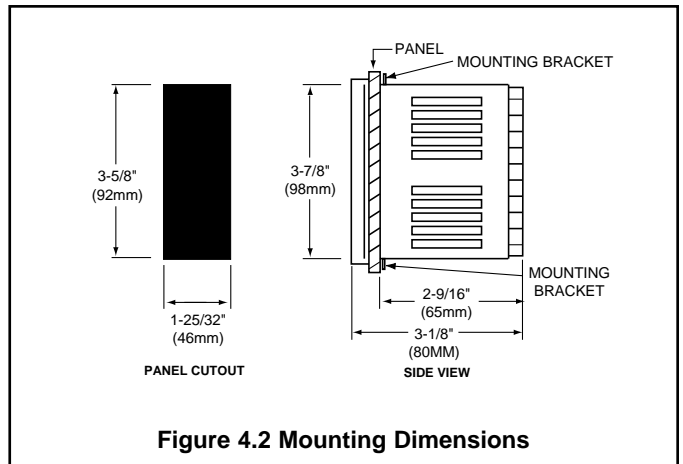
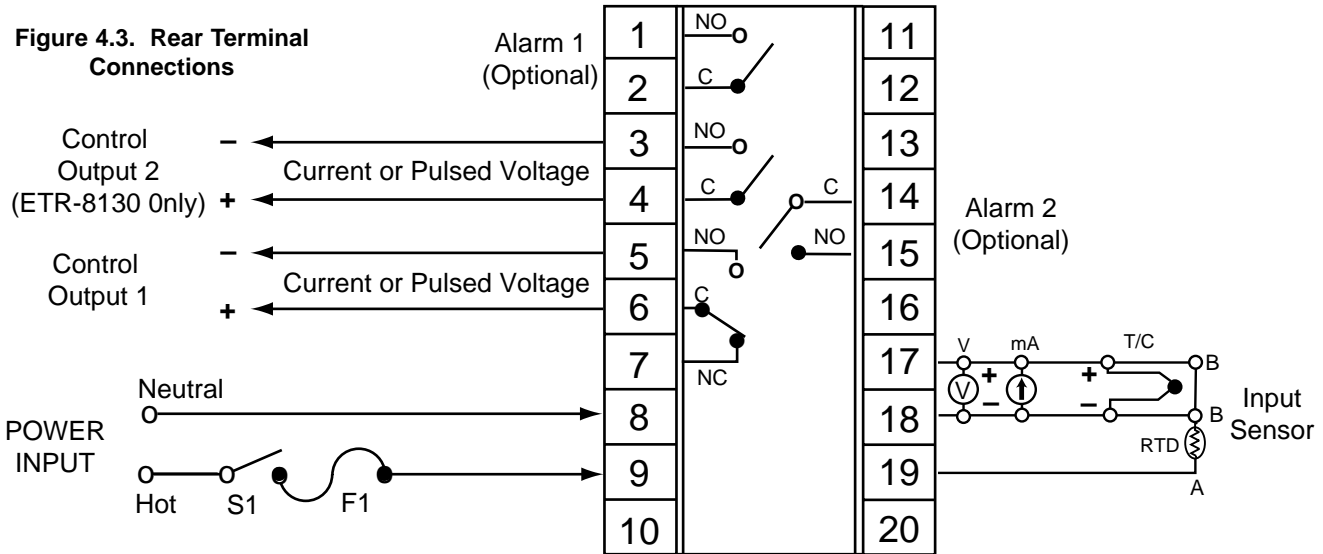

Figure 4.2 Mounting Dimensions

Power Wiring:

Connect terminals as shown in Figure 4.3. The power switch S1 and Fuse F1 are included for illustrative purposes only. For ETR-8120 sample wiring diagrams,

refer to Figures 4.4, 4.5, 4.6, 4.7 and 4.8 on the following pages. For ETR-8130 sample wiring diagrams, refer to Figures 4.9, 4.10, 4.11, 4.12 and 4.13.



Input Wiring:

Connect appropriate sensor to terminals 17, 18 or 19 as illustrated above. Verify that the instrument is selected for the correct sensor and the correct polarity is observed at both the sensor-end and instrument-end of the cable. Do not run sensor cables in the same conduit or wiring trough as power lines because the low level signal is noise sensitive.

When wiring the thermocouple, check the thermocouple and extension wire (compensating cable) to make sure they conform to the appropriate thermocouple type

specified by the instrument. Extension wires must be the same alloy and polarity as the thermocouple. The total lead resistance should not exceed 100 ohms for accurate measurements. One hundred ohms of lead resistance will introduce a 1°F (0.5°C) error.

For wiring 3 wire RTD (Resistance Temperature Detector) all leads connecting the RTD to the controller must be the same gauge and material. If the RTD is a 3 wire device, install the two common wires of the RTD to terminals 17 and 18. If a 2 wire RTD is to be used, install a jumper between terminals 17 and 18.

Table 4.1 International Thermocouple Cable Color Codes

Thermocouple Type	Cable Material	American ANSI	British BS 1843	German DIN 43710	French NFE 18001
J	Iron/Constantan	+ white - red * black	+ yellow - blue * black	+ red - blue * blue	+ yellow - black * black
K	Chromel/Alumel	+ yellow - red * yellow	+ brown - blue * red	+ red - green * green	+ yellow - purple * yellow
T	Copper/Constantan	+ blue - red * blue	+ white - blue * blue	+ red - brown * brown	+ yellow - black * black
R S	Platinum/Rhodium	+ black - red * green	+ white - blue * green	+ red - white * white	+ yellow - green * green
B	Platinum/Rhodium	+ grey - red * grey		+ red - grey * grey	

* Color of overall sheath

Chromel® and Alumel® are registered trademarks of Hoskins Mfg. Co.

ETR-8120 WIRING DIAGRAMS

Figure 4.4
ETR-8120-31211
Thermocouple Input
Relay Output
No Alarms

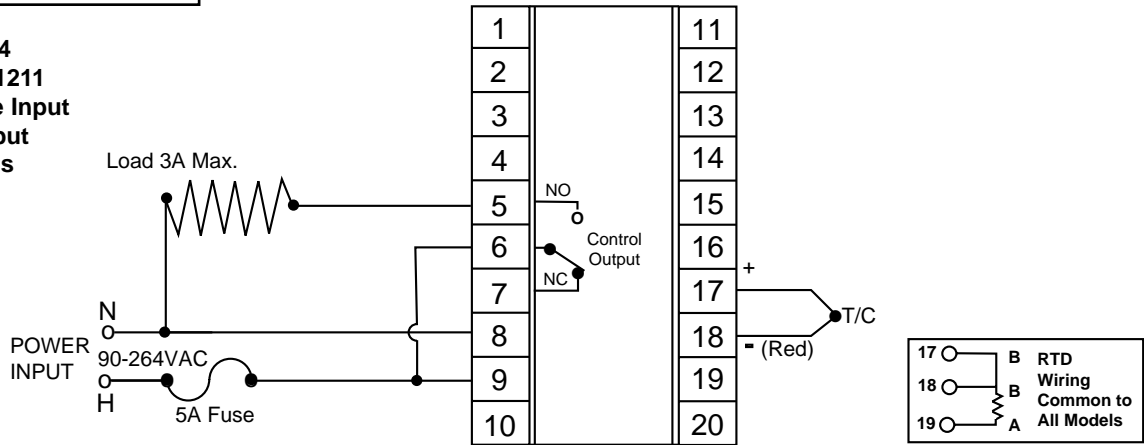
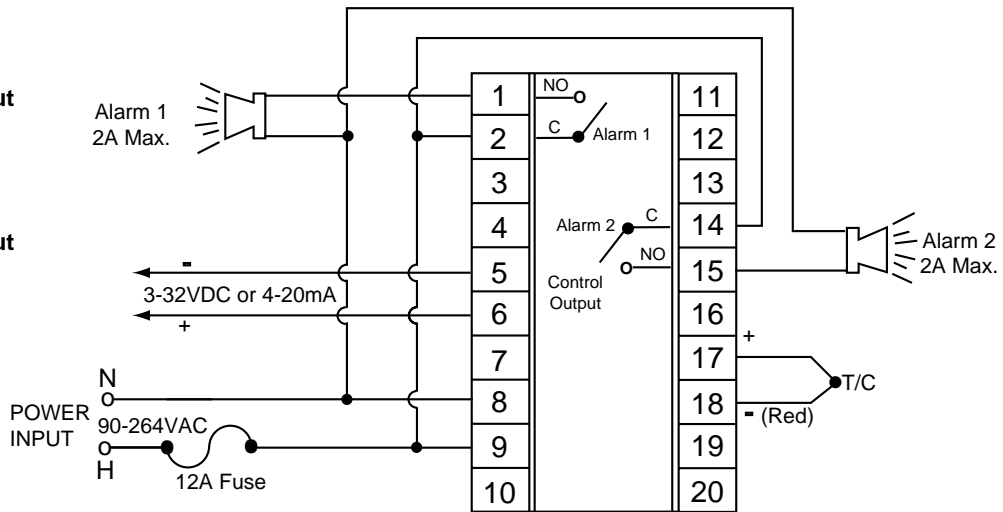

Figure 4.5
ETR-8120-31321
Thermocouple Input
3-32VDC Output
Dual Alarms



ETR-8120-31521
Thermocouple Input
4-20mA Output
Dual Alarms

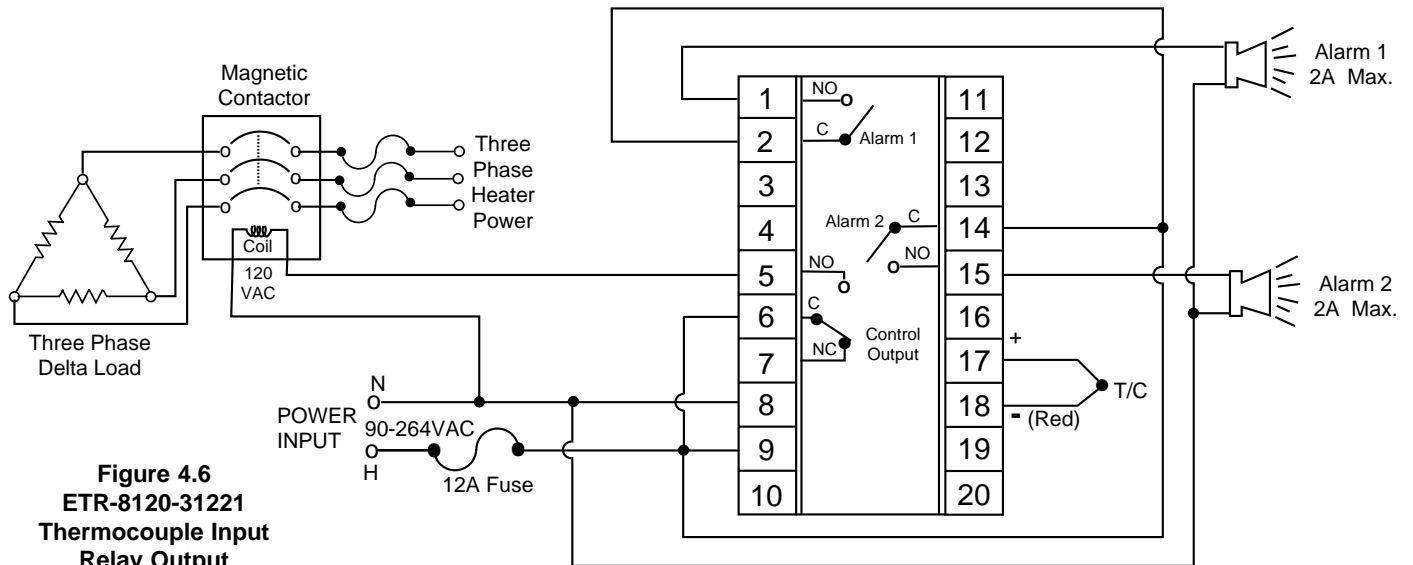

Figure 4.6
ETR-8120-31221
Thermocouple Input
Relay Output
Dual Alarms
With Contactor for
3-Phase Load

Figure 4.7
ETR-8120-31221
Ramp and Soak
Thermocouple Input
Relay Output
One Alarm
Dwell Time Relay Off
ALA1 = 12

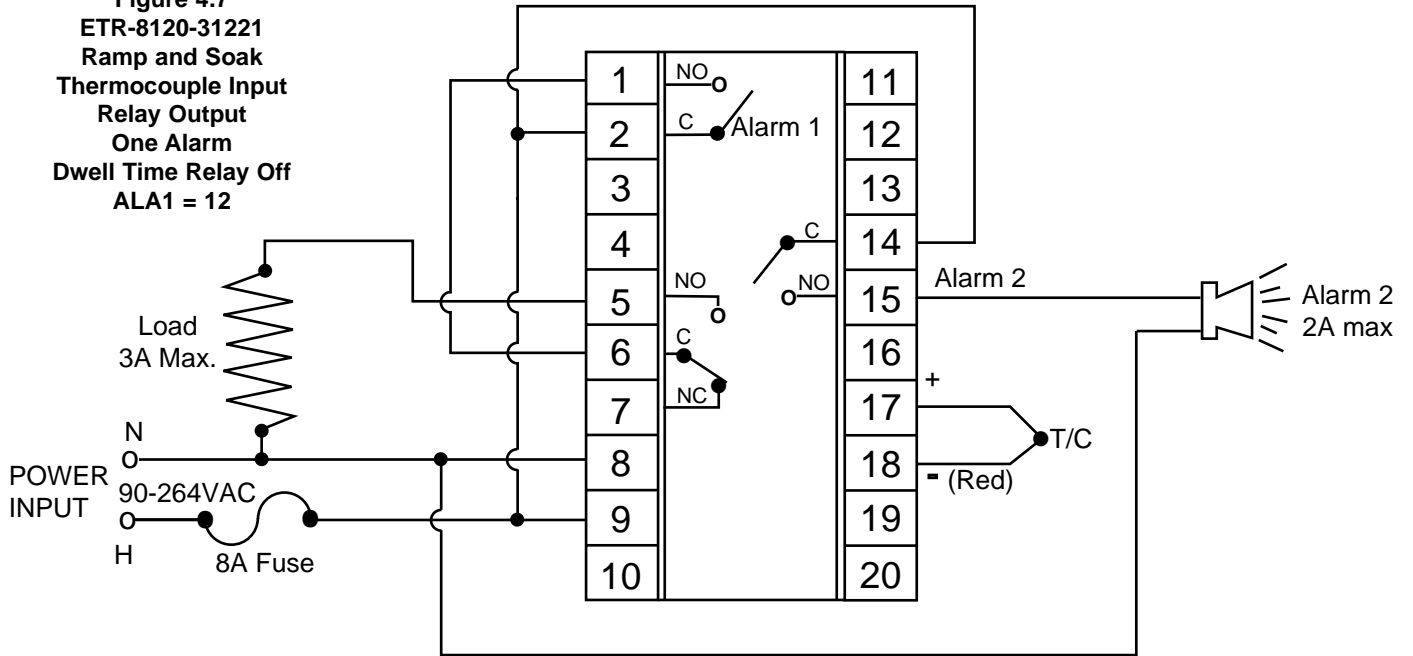
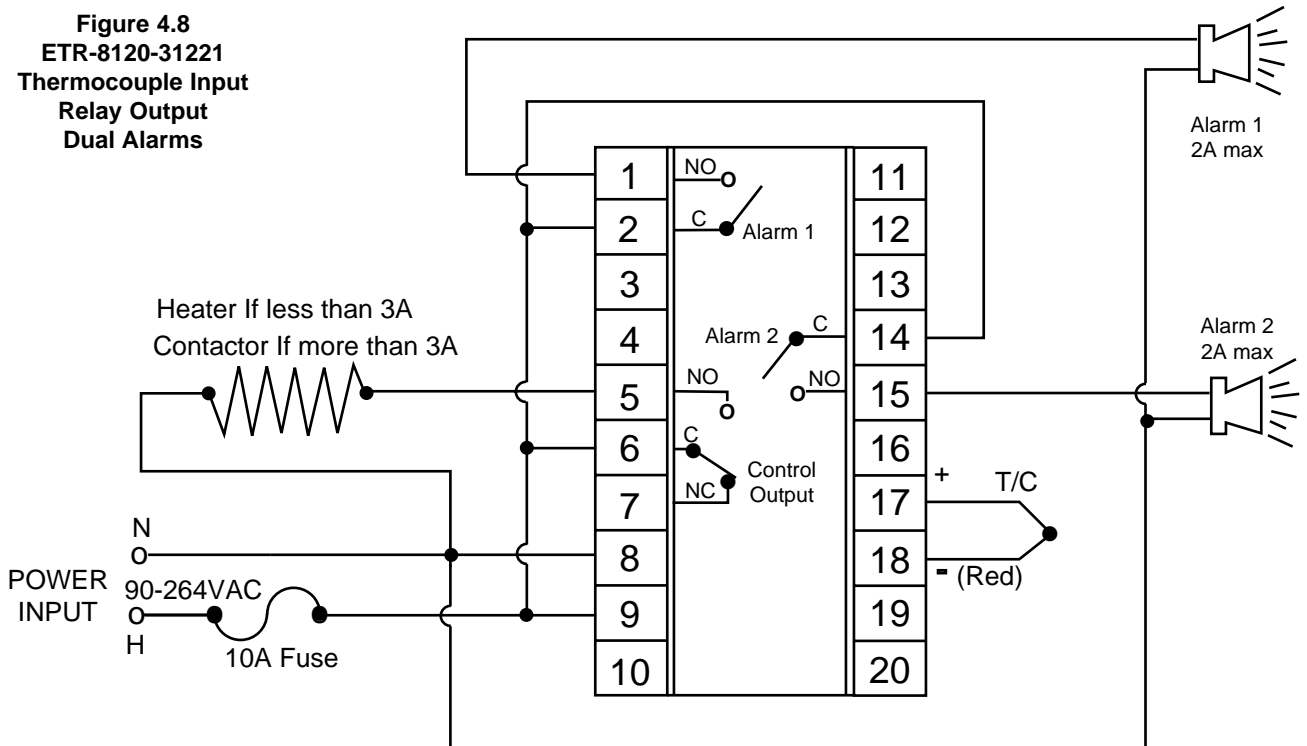

Figure 4.8
ETR-8120-31221
Thermocouple Input
Relay Output
Dual Alarms



A contactor or external relay must be used with loads that exceed 3 amps for control outputs and 2 amps for alarm outputs.

ETR-8130 Wiring Diagrams

Figure 4.9
ETR-8130-312211
Thermocouple Input.
Relay Output for
heating and cooling

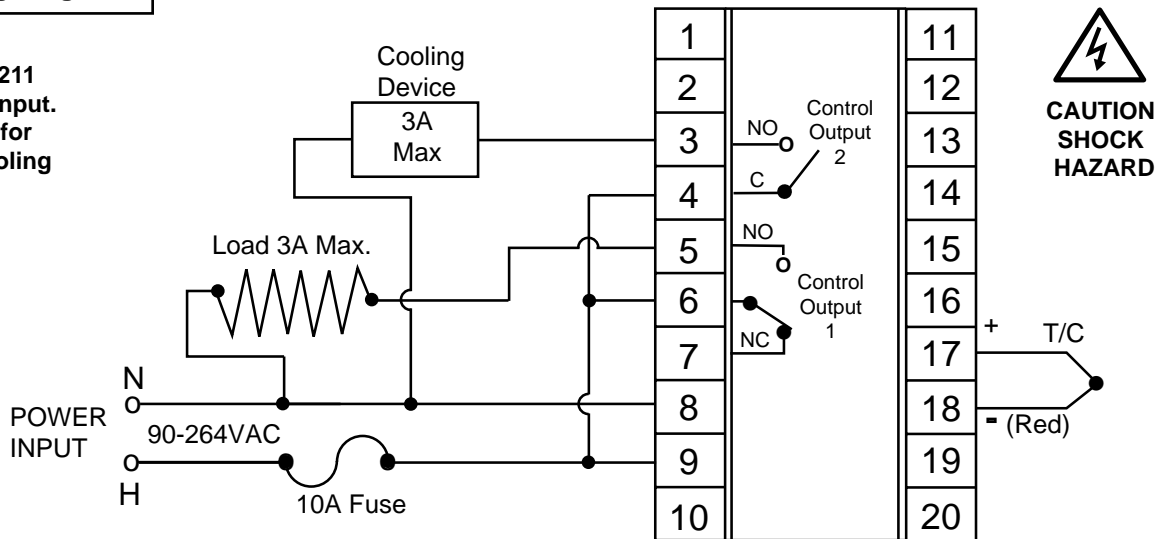

Figure 4.10
ETR-8130-313211
Thermocouple Input
SSR Output 1
Relay Output 2

ETR-8130-315211
Thermocouple Input
4-20mA Output
Relay Output 2

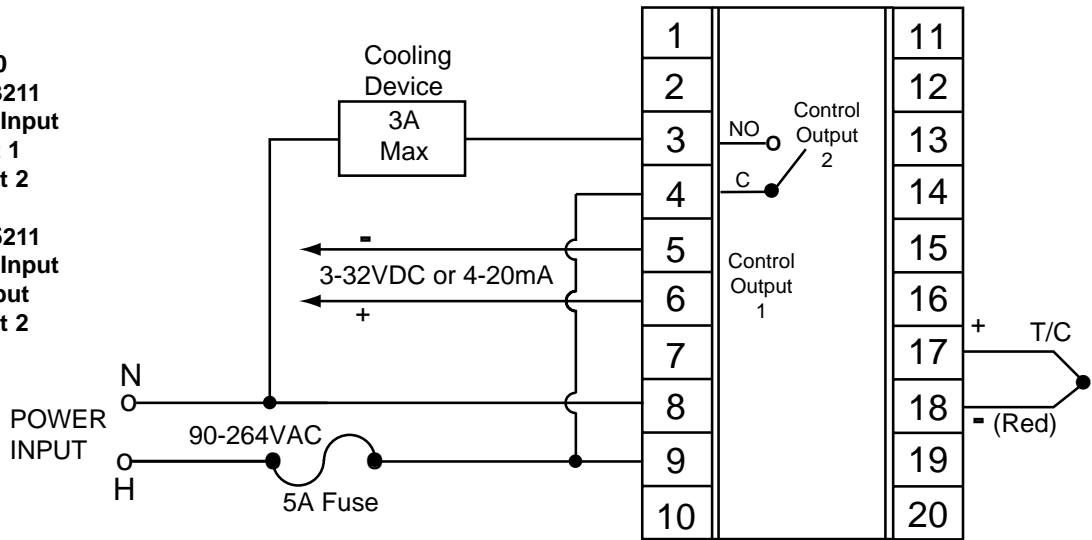
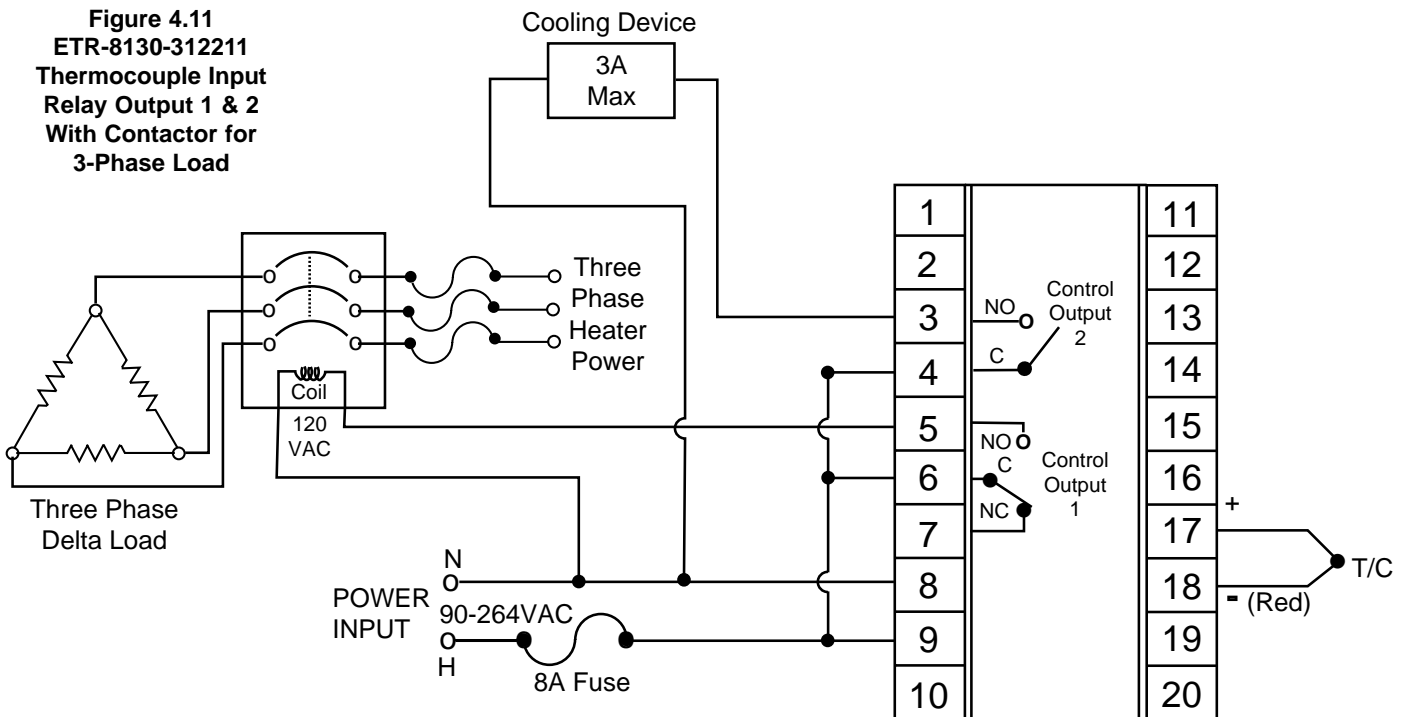

Figure 4.11
ETR-8130-312211
Thermocouple Input
Relay Output 1 & 2
With Contactor for
3-Phase Load



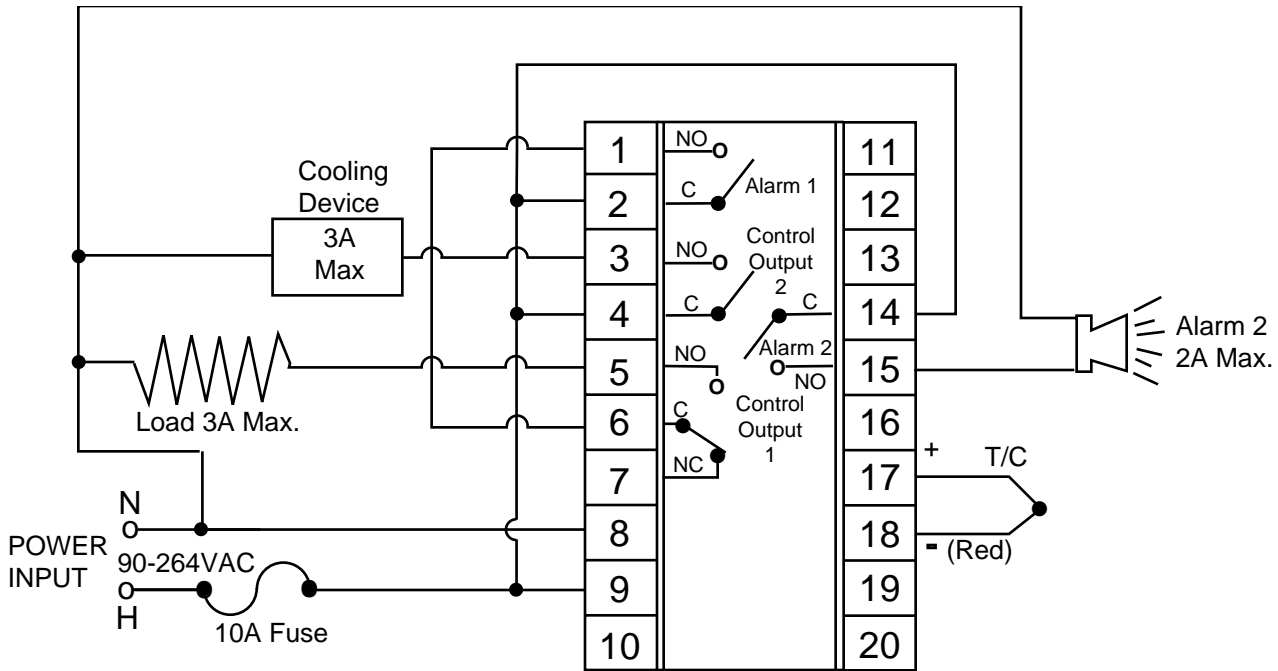

Figure 4.12
ETR-8130-312221
Ramp and Soak
ALA1 = 12
Dwell Time Out
Relay Output 1 and Output 2

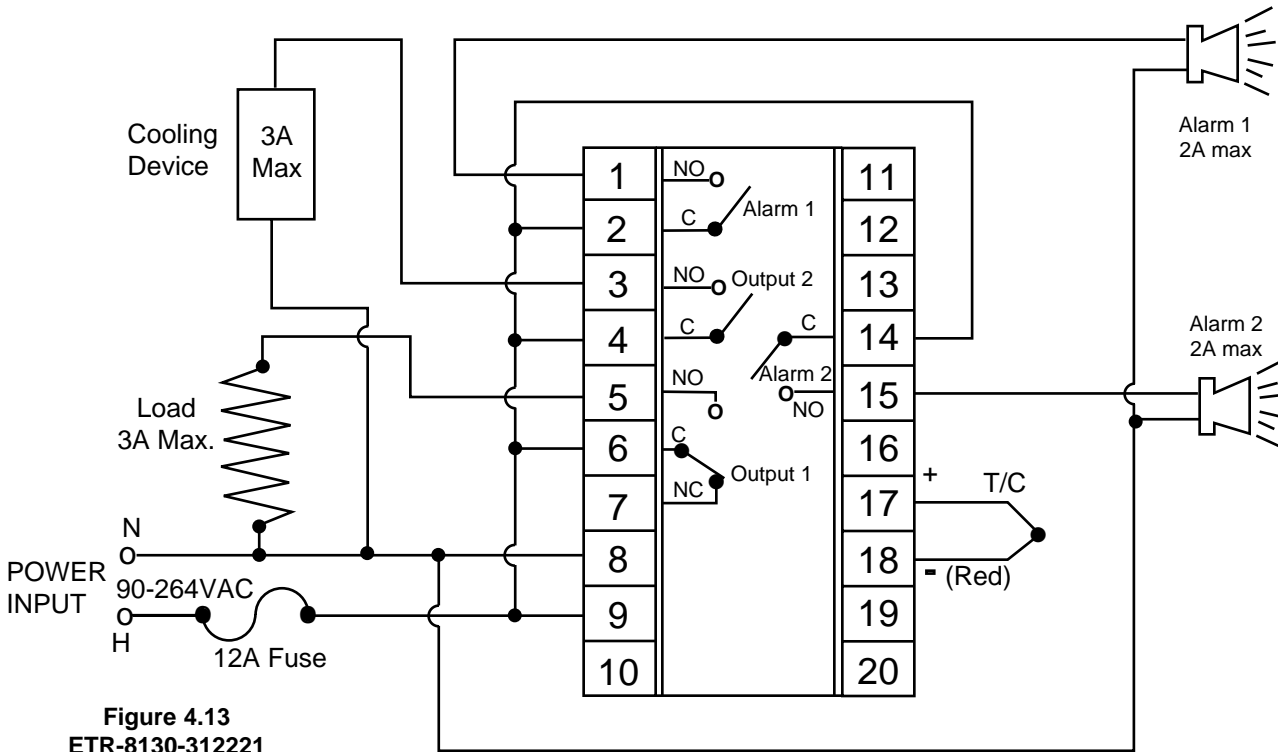

Figure 4.13
ETR-8130-312221
Thermocouple Input
Heating and Cooling
Outputs with Alarms

Table 4.2 Heating Output Wiring

Function	Internal Device: Terminals:	External Connection:
1. Relay (Isolated). Relay contact is closed during ON phase of output cycle. (OUT lamp ON)		To line 240VAC max.
2. Linear Current (Isolated). Reverse acting current (The function of OUT lamp ON lasts longer during decreasing process value).		Input impedance of control device, MAX. 500 ohms.
3. Linear Voltage (Isolated). Reverse acting voltage (The Flashing of OUT lamp ON lasts longer during decreasing process value).		Input impedance of control device, MIN. 500K ohms.
4. Pulsed Voltage. The non-isolated logic signal goes high during ON phase of output cycle. (OUT lamp ON).		To drive solid state relay or other isolated control device 24 VDC/20mA MAX.

Output Wiring:

Four different types of output devices can be used from output one. Relay, current, voltage and pulsed voltage provide a variety of control applications. Verify that the output device is correctly selected to meet your application requirements and make certain the ratings of the output devices are not exceeded before wiring the system.

The external connections depend on what type of output is installed. Pulsed voltage output is not isolated from the internal circuits of the instrument.

Alarm

This instrument offers 14 different alarm modes. Each one can be selected by pressing the keypads on the front panel. The detailed descriptions are shown on Table 5.4, Page 14 and on Table 5.8, Page 21.

Sensor Placement

Proper sensor placement can eliminate many problems in a control system. The probe should be placed so that it can detect any temperature change with minimal thermal lag. In a process that requires fairly constant heat output, the probe should be placed close to the

heater. In processes where the heat demand is variable, the probe should be closer to the work area. Some experimenting with probe location is often required to find this optimum position.

In a liquid process, addition of a stirrer will help to eliminate thermal lag. Since the thermocouple is basically a point measuring device, placing more than one thermocouple in parallel will provide an average temperature reading and produce better results in most air heated processes.











Proper sensor type is also a very important factor in obtaining precise measurements. The sensor must have the correct temperature range to meet the process requirements. In special processes the sensor might have to have different requirements such as leak-proof, anti-vibration, antiseptic, etc.

Standard sensor limits of error are ± 4 degrees F (± 2 degrees C) or 0.75% of sensed temperature (half that for special) plus drift caused by improper protection or over-temperature occurrence. This error is far greater than controller error and cannot be corrected at the sensor except by proper selection and replacement.

Section 5: OPERATION

Front Panel Adjustments

Table 5.1 Keypad Operation

TOUCHKEYS	FUNCTION	DESCRIPTION
	Scroll Key	Advances the index display to the desired position. Parameters advance continuously and cyclically by pressing this keypad.
	Up Key	Increases the parameter.
	Down Key	Decreases the parameter.
	Return Key	Resets the controller to the Process Value. Also stops auto-tuning, output percentage monitoring and manual mode operation.
Press  for 6 seconds	Long Scroll	Allows more parameters to be inspected or changed. Allows the controller to move from the end of one level to the next level.
Press  for 6 seconds	Long Return	1. Executes auto-tuning function. 2. Calibrates control when in calibration level.
Press  and 	Output Percentage Monitoring	Allows the set point display to indicate the control output value in percent.
Press  and  for 6 seconds	Manual Mode Execution	Allows the controller to enter the manual mode. This can be used if the sensor fails.

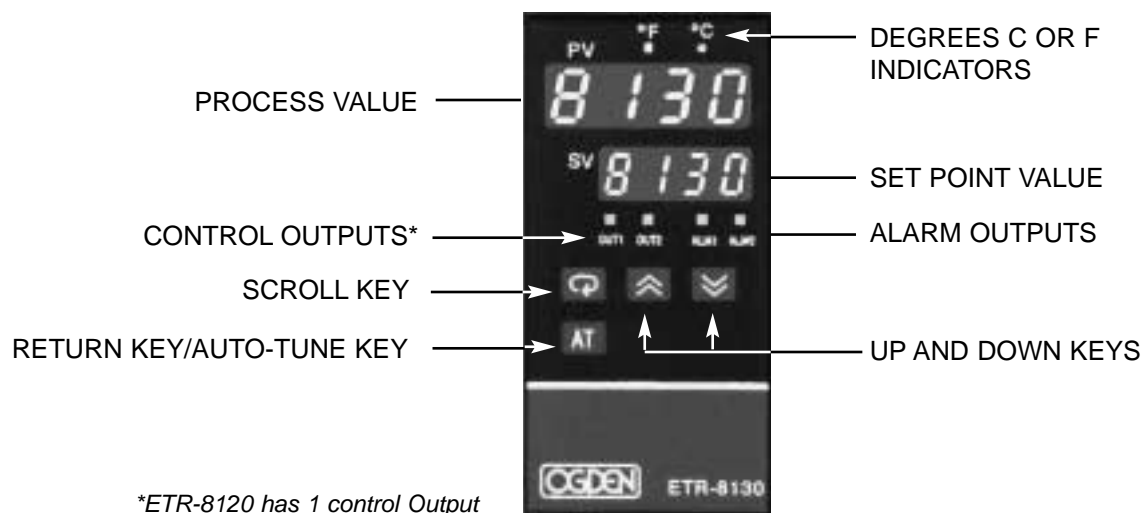

*ETR-8120 has 1 control Output

ETR-8120

Table 5.2 ETR-8120 Control Function and Display Flow Chart

PROCESS VALUE DISPLAY SET VALUE DISPLAY AND ADJUSTMENT

Long (6 seconds)

ASP1
 r r
 oFSt
 ASP2
 SHIF
 Addr
 Pb
 t1
 td

Long (6 seconds)

LoCL
 SEL
 Ct
 in
 ALn1
 ALn2
 AHY1
 AHY2
 CF
 rESo
 ConR
 ErPr
 HYSL
 LLit
 HLit

Long (6 seconds)

LCAL
 HCAL

The "return" (AT) key can be pressed at any time. This will prompt the display to return to the Process Value/Set Value.

- Power Applied:
- 8120 43.3 Displayed for 2 seconds (Software Version 3.3 or higher)
 - 8888 8888 LED test. All LED segments must be lit for 2 seconds.
 - Process value and set point indicated.

WARNING: Do not enter Level 4 unless you have proper calibration instruments. Refer to Page 23 for further information.

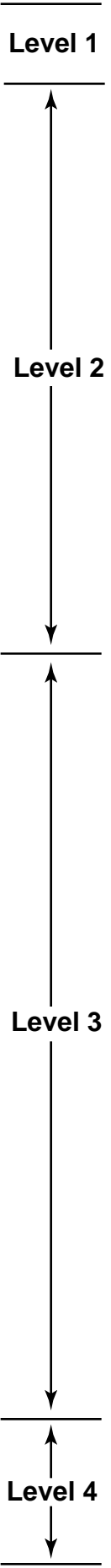

ETR-8130

Table 5.3 ETR-8130 Control Function and Display Flow Chart

PROCESS VALUE DISPLAY SET VALUE DISPLAY AND ADJUSTMENT

Long (6 seconds)

ASPI
r r
oFSt
ASp2
SH.F
Addr
Pb
CPb
db
t1
td

Long (6 seconds)

LoCL
SEL
Et
CCt
in
ALn1
ALn2
AHY1
AHY2
CF
rESo
ConR
ErPr
HYSt
LLit
HLit

Long (6 seconds)

LCAL
HCAL

The "return" (AT) key can be pressed at any time. This will prompt the display to return to the Process Value/Set Value.

- Power Applied:
- 8130 v3.3 Displayed for 2 seconds (Software Version 3.3 or higher)
 - 8888 8888 LED test. All LED segments must be lit for 2 seconds.
 - Process value and set point indicated.

WARNING: Do not enter Level 4 unless you have proper calibration instruments. Refer to Page 23 for further information.

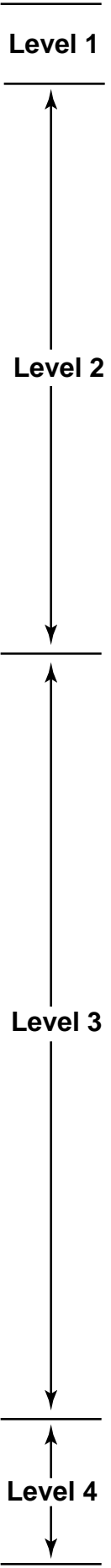

Table 5.5 Parameter Record Sheet

Parameter	Control No.	Date
SV SET POINT VALUE		
<i>ASP1</i> ALARM SET POINT 1		
<i>rr</i> RAMP RATE		
<i>oFSt</i> OFFSET		
<i>ASP2</i> ALARM SET POINT 2		
<i>SHiF</i> DISPLAY SHIFT		
<i>Addr</i> ADDRESS		
<i>Pb</i> PROPORTIONAL BAND HEAT		
<i>CPb</i> * PROPORTIONAL BAND COOL		
<i>db</i> * DEAD BAND		
<i>t_i</i> INTEGRAL TIME		
<i>t_d</i> DERIVATIVE TIME		
<i>LoCL</i> LOCK OUT		
<i>SEL</i> SELECT PARAMETERS		
<i>CT</i> CYCLE TIME		
<i>CCt</i> * COOLING CYCLE TIME		
<i>in</i> INPUT MODE		
<i>ALn1</i> ALARM MODE 1		
<i>ALn2</i> ALARM MODE 2		
<i>HY1</i> HYSTERESIS ALARM 1		
<i>HY2</i> HYSTERESIS ALARM 2		
<i>CF</i> DEGREES C OR F		
<i>RES</i> RESOLUTION		
<i>ConA</i> CONTROL ACTION		
<i>ErPr</i> ERROR PROTECTION		
<i>HYS</i> HYSTERESIS ON-OFF		
<i>LLiE</i> LOW LIMIT RANGE		
<i>HLiE</i> HIGH LIMIT RANGE		

PARAMETER DEFINITIONS:

PV - Process Value - This is the temperature (or other process variable) as measured at the sensor. This will indicate a value within the range between the low scale value (LLiE) and High scale value (HLiE). This indication will read an error code if the temperature (process variable) goes out of the preset span. Note items 4 and 5 of the troubleshooting guide on page 25 for the error code descriptions.

SV - Set Point Value - This parameter is the desired set point of the process. It can be adjusted within the range defined by the low scale (LLiE) and high scale value (HLiE). The span adjustments can be used to limit the set point setting of the controller.

ASP1 - Alarm Set Point Value or Dwell Time - This sets the point at which the alarm will energize if ALAI (alarm mode selection) is set for an alarm function. If ALAI is selected for the dwell timer function (setting 11 or 12), then this becomes the timer setting in minutes. The dwell timer starts counting when the process value reaches the set point value. Note page 21 for more information.

rr - Ramp Rate - This controls the heat-up and cool-down rate of the process. This setting is in degrees per minute. Note page 18 for more information.

oFST - Offset Value - This parameter is only functional if the integral time (Ti) is set to zero. The oFST than functions the same as manual reset to correct the process temperature to the set point temperature. If the process temperature stabilizes below the set point, set a positive amount of oFST. If the process temperature stabilizes above the set point, set a negative amount of oFST. Wait for the system to stabilize and make further adjustments as required. The number observed in this parameter can be ignored if you have a number greater than 1 entered in the integral setting (Ti).

SHiF - Display Shift - A value entered here will be added to or subtracted from the Process Value. This offset can be used as a correction factor if the sensor does not read the same temperature as the item being sensed. It can also be used to correct for calibration. Note page 20 for more information.

Pb, Ti and Td - PID Values - Proportional band (Pb), Integral (Ti) and Derivative (Td) time constants. These must be set as close as possible to the process application requirements. During auto-tuning, these parameters will be adjusted. Note pages 16, 17 and 18 for more information.

LoCL - Local Mode - Used to disable the up and down buttons to prevent tampering.

SEL - Select - Used to upgrade commonly used parameters to Level 1.

CT - Proportional Cycle Time - This sets the proportional cycle time for the control output. This should be set according to the type of output device used. For mechanical relays, cycle times of 15 to 20 seconds are used. For solid-state relays, set this adjustment to 1 or 0. For 4-20mA or other linear outputs, adjust to 0.

in - Input Mode Selection - This parameter is used to program the control to the type of input sensor used.

ALAI - Alarm Mode Selection - This adjustment sets the type of alarm (or dwell timer) to be used: deviation alarm, band alarm or process alarm. Refer to page 21 for more information.

(Continued on next page.)

* These parameters are not present in ETR-8120 Controls.

AHY1 - Hysteresis of Alarm - The value entered here defines the deadband for the alarm. The alarm will not change state until the temperature is outside of the deadband.

CF - Degrees Selection - Sets the indication to degrees Celsius or Fahrenheit.

rESO - Display Resolution - This parameter is used to place a decimal point in the process and set point values. A two-place decimal point can only be used if the "in" adjustment is set to 10; linear voltage or current.

ConA - Control Action - This parameter selects heating (reverse) or cooling (direct) action for the control output.

ErPr - Error Protection - Sets the control and alarm output to be used in case of sensor failure.

hYSE - Hysteresis of On-Off Control - This parameter defines the deadband when on-off control is used and PID control has been disabled. For on-off control, set Pb, Ti and Td to 0. The output on a relay control will not change state until the temperature is outside of the deadband. Note below for more information.

LLiE, HLiE - Low Scale/High Scale Range - The parameters are used to define the range (span) of the control. These should be set for the requirements and safety of your process. Refer to "Span Adjustment" below for further information.

Operating Procedure:

When the control has been wired, you can apply power. The display will indicate the model number, software version and LED lamp test. The temperature as measured at the sensor should now be indicated by the PV display. The thermocouple is wired in reverse if the indicated temperature decreases as the temperature at the thermocouple increases. The set point should be lowered to a value (eg. 30°F) so the heaters will not be energized. This will allow time to enter and make any adjustments of the parameters. The process will not heat-up.

Span Adjustment:

During this initial set-up, alarm points and any other settings can now be made. The low limit and high limit range settings (LLiE) and (HLiE) should be adjusted to your process. This sets the range (SPAN) of the control. The set point cannot be adjusted out of this range. For plastics processing and packaging, a span of 0-800°F is common. If oils are used, a lower span such as 0-300°F should be entered.

Automatic Tuning Procedure

When the settings have been made, you can return to the PV/SV level. Do not enter the calibration level. Adjust the required process temperature set point. The green "output" lamp should turn on indicating the heaters have been energized. You can auto-tune the control to the set point by depressing the return () button for six seconds, then release. This matches the control's PID values to your process requirements. The lower decimal point will flash, indicating the control is in the auto-tune mode. No other adjustments can be made while the control is auto-tuning. During auto-tuning, the process will take approximately twenty-five percent longer to heat-up than it normally takes. After auto-tuning, the correct PID values will be entered into the control's memory.

Auto-tuning will not function if the control has been configured from PID to ON-OFF. For electric heating, PID is usually recommended.

Auto-tuning may not give satisfactory results and hold a close temperature on all applications. If this occurs, you can change the PID values manually using the three charts in Figure 5.1 on the top of the next page and Table 5.6 for a guide. It is recommended to change only one parameter at a time, so the results of that change can be clearly noted.

ON-OFF Control:

On-off control action is recommended when continuous cycling of the load cannot be used. Examples are mechanical solenoids, large contactors and valves. For on-off control, set the following parameters to zero: proportional band; integral; derivative and offset (oFSE). The hysteresis (hySE) adjustment is now used to set the deadband. The larger the hysteresis is set, the larger the deadband will be. A large deadband will cause the contactor (or other device) to switch less often, but the process will oscillate farther from the set point. This setting is measured in degrees.

Adjusting PID Parameters:

The PID parameters can be reviewed by operating the scroll key and noting whether the values are reasonable or not. Examine the controller's result. Modify the PID parameters, if necessary, according to Table 5.6 on page 18 until the control quality is acceptable.

PID Control

For various applications, the controller can be used as P control only (set integral = 0, derivative = 0); PI control (set derivative = 0), PD control (set integral = 0), and PID control.

Figure 5.3 on page 17 represents the response of a typical control system using various modes of control.

- 1.) P control results in a response showing a deviation (offset), a high overshoot and a moderate period of oscillation. In addition, a significant length of time is required before the system ceases to oscillate.
- 2.) PI control has no offset, but elimination of offset comes at the expense of higher overshoot, larger period of oscillation and a longer time required for oscillations to cease compared with other modes of control.
- 3.) PD control generally brings the system to steady state in the shortest time with the least oscillation. However, it still has offset.
- 4.) PID control is essentially a compromise between the advantages of PI and PD control. Offset is eliminated by the integral action. The derivative action serves to lower overshoot and to eliminate some of the oscillation realized with PI control.

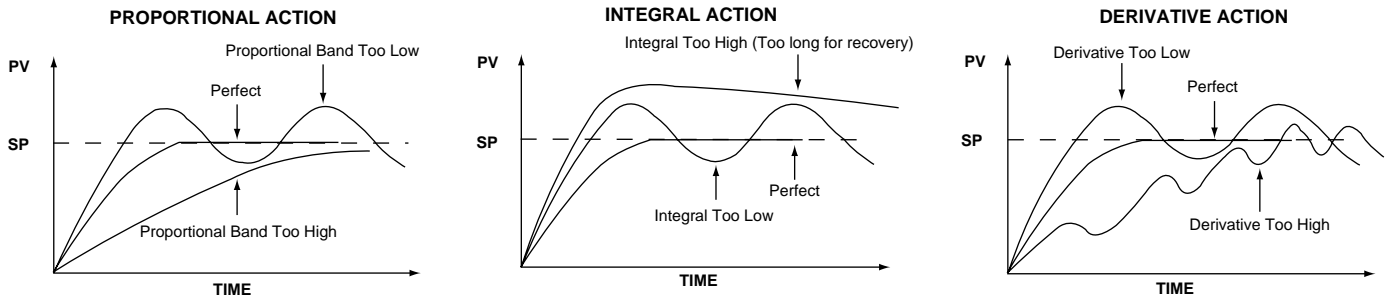

FIG 5.1 Effects of PID Adjustment on Process Response

The proportional band (Pb) is a temperature band expressed in degrees. When the controller is within this band, the time proportioning functions are active.

Integral action (automatic reset) corrects for offset (load error) for load variations. Reset wind-up inhibition prevents integral action from occurring outside of the proportional band. Software antisaturation minimizes process oscillations when the load changes.

Derivative action is adjusted to match the response time of the process and to compensate the integral action. Correct adjustment provides power output compensation for process load variations. It also minimizes overshoot and oscillations at start up or in large process upsets.

Manual Tuning Procedures:

For some systems it is difficult to execute automatic tuning or the automatic tuning results are not satisfactory. The following steps can then be used for initial tuning of a three-mode control:

- Step 1: Adjust the integral and derivative values to 0. This inhibits the rate and reset action.
- Step 2: Set an arbitrary value of proportional band and monitor the control results.
- Step 3: If the original setting introduces a large process oscillation then gradually increase the proportional band until the oscillation disappears.
- Step 4: If the original setting does not introduce process

oscillations then gradually decrease the proportional band until steady cycling is observed. Record this important proportional band percentage (Pc).

- Step 5: Time the period of steady cycling. Record this critical period Tc. The PID parameters are determined as:

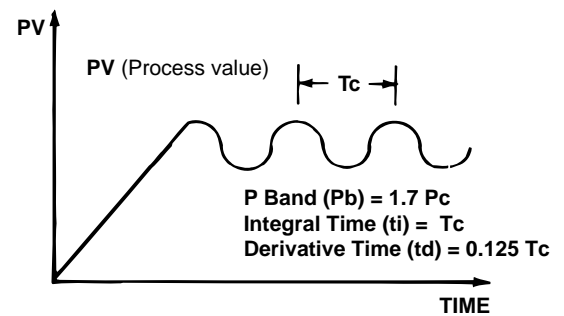

Fig. 5.2 Steady State Cycling

This method was developed by Ziegler and Nichols. If you are unfamiliar with tuning PID Controllers, we suggest that you obtain and become familiar with the following reference material: Tuning of Industrial Control Systems by A.R. Corripio ISBN: 1-55617-253-2-Q. Available from: ISA Publications and Training Aids, Phone: 919-549-8411.

This method should be performed with a temperature chart recorder.

Fig. 5.3 Response of a Typical Control System Using Various Modes of Control

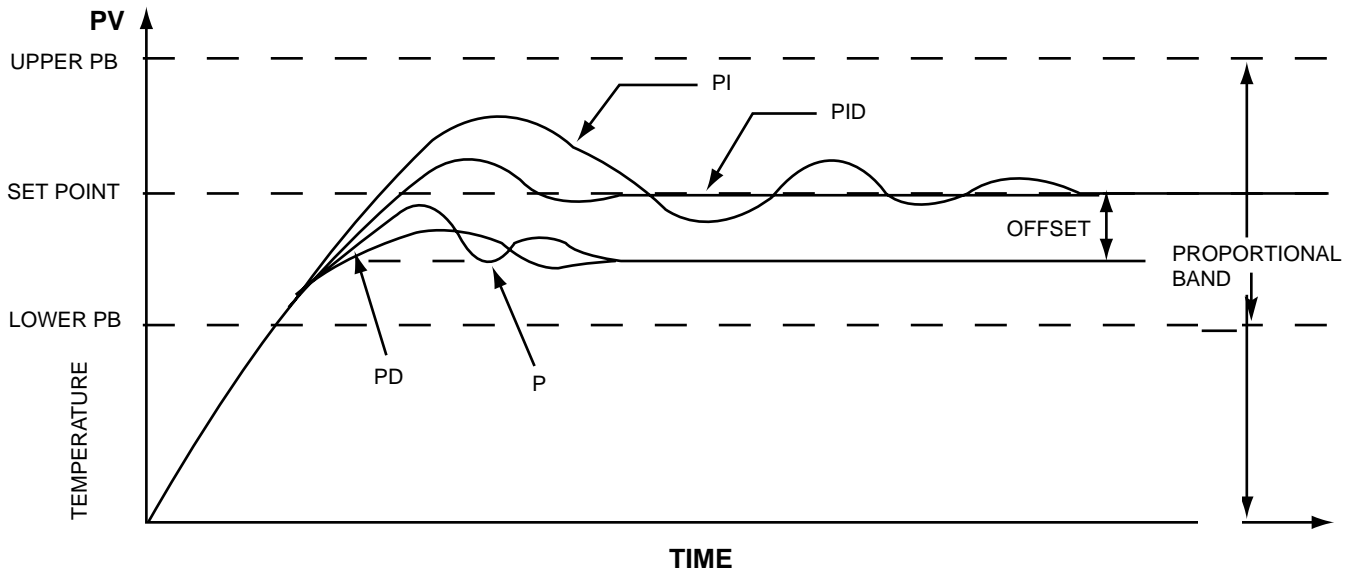

Table 5.6 Tuning Guide

ADJUSTMENT SEQUENCE:	SYMPTOM:	SOLUTION:
1.) Proportional Band	Slow Response	Decrease Proportional Band (Pb)
	High Overshoot or Oscillations	Increase Proportional Band (Pb)
2.) Integral Time (Reset)	Slow Response	Increase Reset (i.e. Decrease Integral Time)
	Instability or Oscillations	Decrease Reset (i.e. Increase Integral Time)
3.) Derivative Time (Rate)	Slow Response or Oscillations	Decrease Rate (i.e. Decrease Derivative Time)
	High Overshoot	Increase Rate (i.e. Increase Derivative Time)

RAMP RATE ADJUSTMENT

The purpose of this adjustment is to control the rate at which the process temperature can change. This feature would be used when rapid temperature changes could damage the product being controlled. When used, the ramp rate is in effect at all times, during heat-up, set point changes and cool-down.

The ramp rate (rr) is expressed in degrees/minute

EXAMPLE 1: The process temperature cannot change more than 5 degrees per minute.

Adjust $rr = 5$

EXAMPLE 2: The process temperature cannot change more than 60 degrees per hour.

Adjust $rr = 1$

The ramp rate is not functional if rr is set to zero.

Manual Mode Operation:

It is suggested to use Manual Mode (open loop operation) during the time the controller's sensor is not functioning and the control is unable to display the correct process value. This can also be used when automatic control (closed loop) is not possible or during the time required to test the characteristics of a process.

In order to enter the manual mode operation press both the "Scroll" key and the "Return" key for longer than 6 seconds and release. Now the control will display the output percentage with a range of -100% to 100%. A positive value for heating output percentage and a negative value for cooling output percentage. Press the UP or DOWN key to adjust the output percentage. Zero output percentage disables the heating output.

Table 5.7 Parameter Lockout

There are 5 levels of parameter security protection. They are shown below in the order of protection.		
LEVEL 1	LOCL = 0	No changes can be made
LEVEL 1	LOCL = 1	Only set point can be changed
LEVEL 2	LOCL = 1	Long scroll at Process Valve
LEVEL 3	LOCL = 1	Long scroll at t_d
LEVEL 4	LOCL = 1	Long scroll at $HLiL$

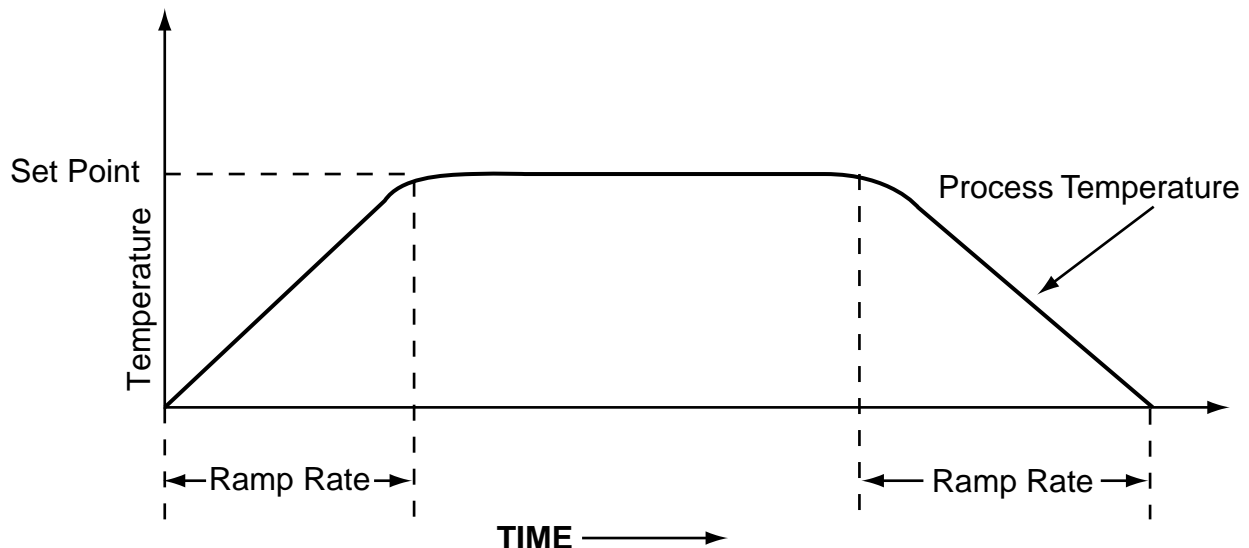
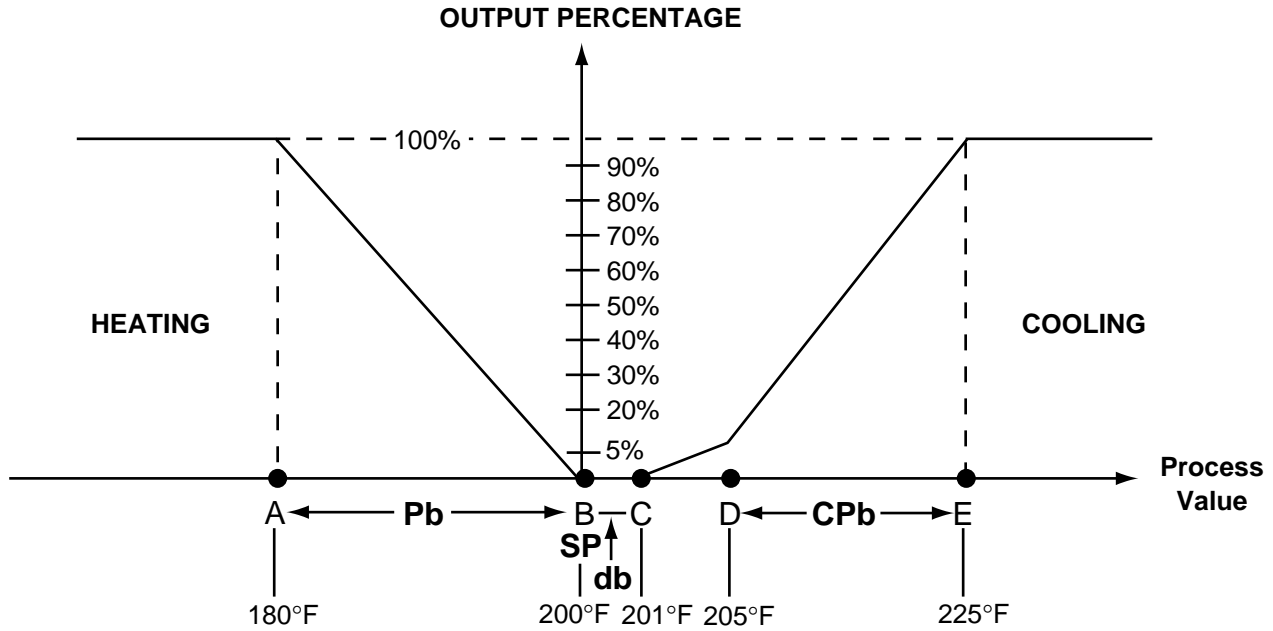

Figure 5.4 Ramp Rate Diagram

Cooling Deadband Adjustment:

This adjustment is used on the ETR-8130 to set the point at which the cooling set point is made. The heating proportional band, cooling proportional band and deadband are described in the following chart:



SP = Set Point (SV)
Pb = Heating Proportional Band
db = Deadband
CPb = Cooling Proportional Band

The points on the chart are:

A = $SP - Pb$
B = SP
C = $SP + (db \times Pb) - (CPb \times Pb/5)$
D = $SP + (db \times Pb)$
E = $SP + (db \times Pb) + (CPb \times Pb)$

An example of the settings of a typical system may be:

Set Point = 200°F
Pb = 20°F
CPb = 1
db = 25%

In this example the points on the chart would be:

A = 180°F $SP - Pb = 200 - 20 = 180$
B = 200°F SP
C = 201°F $SP + (db \times Pb) - (CPb \times Pb/5) = 200^\circ\text{F} + (.25 \times 20) - (1 \times 20/5) = 200 + 5 - 4 = 201$
D = 205°F $SP + (db \times Pb) = 200 + (.25 \times 20) = 200 + 5 = 205$
E = 225°F $SP + (db \times Pb) + (CPb \times Pb) = 200 + (.25 \times 20) + (1 \times 20) = 200 + 5 + 20 = 225$

Increasing the deadband (db) setting will increase the span between the heating and cooling set points. The range of this adjustment is from -100 to +100%.

Figure 5.5 Deadband Adjustment

Display Shift

In certain applications it is desirable to shift the controller's indicated value from its actual value. This can be easily accomplished with this control by using the display shift function. Cycle the control to $5HiF$ parameter by using the "Scroll" pushbutton. The number you adjust here, either positive or negative, will be the amount that the process value (PV) will be shifted from the actual value. This amount will be the same across the entire range of the control. Note the example stated below.

The desired temperature at the part to be heated is 330 degrees F. In order to achieve that temperature, the controlling value or the temperature at the sensor must be 375 degrees F. Due to the design and position of the components of the system, the sensor could not be placed any closer to the work.

Thermal gradients (different temperatures) are common and necessary to an extent in any thermal system for heat to be transferred from one point to another.

The difference between the two temperatures is 45 degrees F. You should input -45 as to subtract 45 degrees from the actual process value (PV).

Cycle the control back to the process value after making this adjustment.

The display shift will alter the process value (PV) only. The set point must be manually adjusted to 330.



DISPLAY BEFORE
INPUT SHIFT



DISPLAY AFTER
INPUT SHIFT.
ADJUST SV TO 330



DISPLAY AFTER SHIFT AND
SV ADJUSTMENT

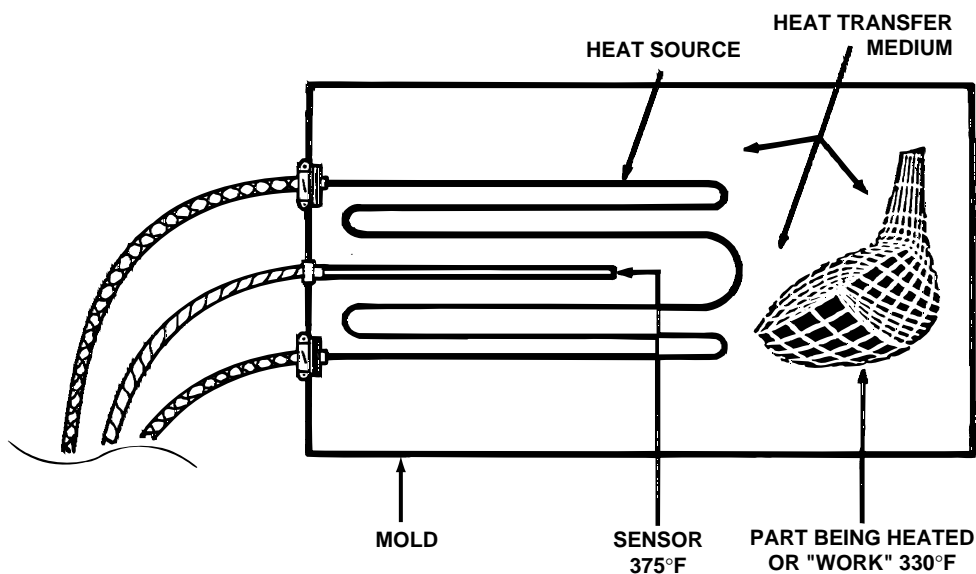

Figure 5.6 Display Shift

Table 5.8 Code Assignments and Description of Alarm Modes

ASP1 = ALARM 1 SET POINT VALUE

ASP2 = ALARM 2 SET POINT VALUE

 ALARM

SV = SET POINT VALUE

<p>$AL_{\bar{n}i}(2) = 0$ PROCESS HIGH ALARM</p> 	<p>$AL_{\bar{n}i}(2) = 1$ PROCESS LOW ALARM</p> 	<p>$AL_{\bar{n}i}(2) = 2$ DEVIATION HIGH ALARM</p> 	<p>$AL_{\bar{n}i}(2) = 3$ DEVIATION LOW ALARM</p> 
<p>$AL_{\bar{n}i}(2) = 4$ INHIBITED PROCESS HIGH ALARM</p> 	<p>$AL_{\bar{n}i}(2) = 5$ INHIBITED PROCESS LOW ALARM</p> 	<p>$AL_{\bar{n}i}(2) = 6$ INHIBITED DEVIATION HIGH ALARM</p> 	<p>$AL_{\bar{n}i}(2) = 7$ INHIBITED DEVIATION LOW ALARM</p> 
<p>$AL_{\bar{n}i}(2) = 8$ OUTBAND ALARM</p> 	<p>$AL_{\bar{n}i}(2) = 9$ INBAND ALARM</p> 	<p>$AL_{\bar{n}i}(2) = 10$ INHIBIT OUTBAND ALARM</p> 	
<p>$AL_{\bar{n}i}(2) = 11$ INHIBIT INBAND ALARM</p> 	<p>$AL_{\bar{n}i} = 12$ DWELL TIME OUT RELAY OFF SOAK CONTROL</p>  <p>ASP1 = MINUTES See Ramp Example on Page 22</p>	<p>$AL_{\bar{n}i} = 13$ DWELL TIME OUT RELAY ON SOAK CONTROL</p>  <p>ASP1 = MINUTES See Ramp Example on Page 22</p>	

Table 5.8 (Continued)

Descriptions of Alarms
Process High Alarm: Alarm is actuated whenever the process value rises above the alarm set point. Changing the control set point does not affect the process alarm trip point.
Process Low Alarm: Alarm is actuated whenever the process value falls below the alarm set point. Changing the control set point does not affect the process alarm trip point.
Deviation High Alarm: Alarm is actuated whenever the process value goes above the control set point by a predetermined (alarm Value) amount. Changing the control set point changes the alarm set point value maintaining the same deviation from the control set point.
Deviation Low Alarm: alarm is actuated whenever the process value falls below the control set point by a predetermined (alarm Value) amount. Changing the control set point changes the alarm set point value maintaining the same deviation from the control set pint. This alarm value is a negative number.

Inhibited alarms do not energize the alarm relay the first time the process temperature enters the alarm area. From the second time the process temperature enters

the alarm area, the Inhibited Alarm offers ON as a normal alarm. For some systems, it is useful to bypass the first alarm section while the system is heating up.

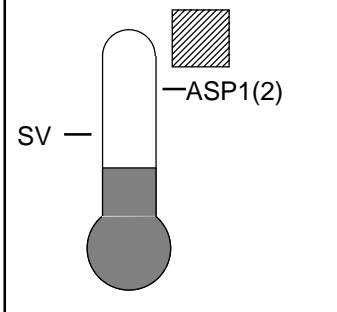
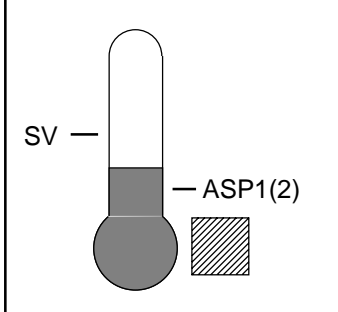
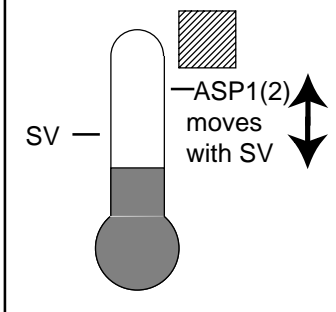
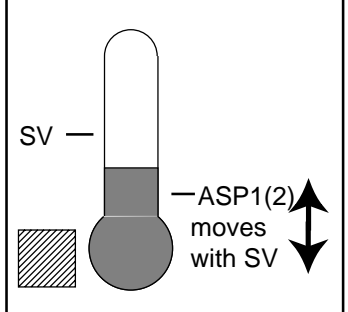
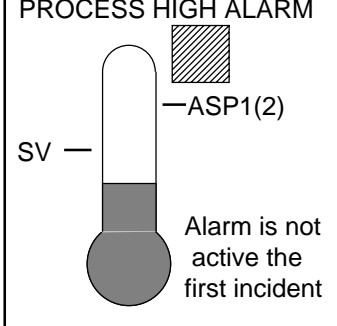
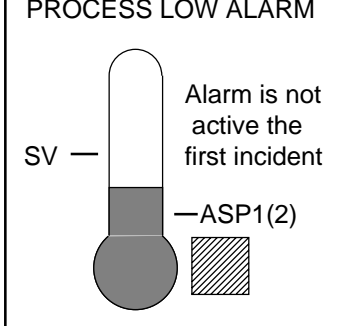
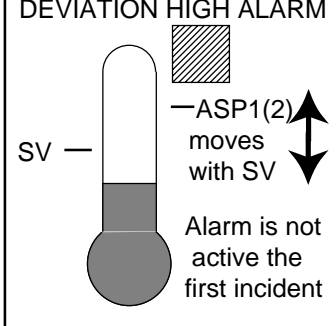
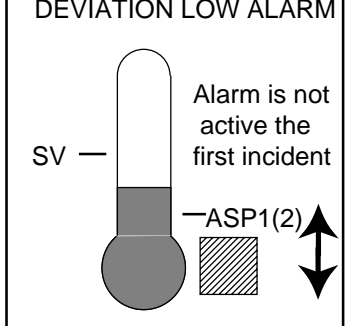
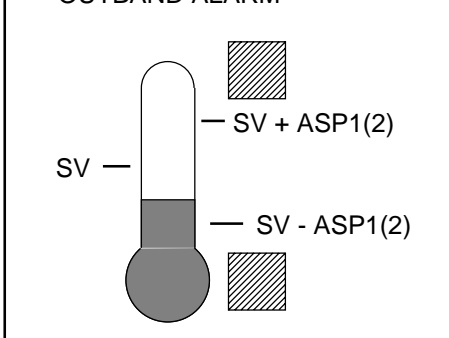
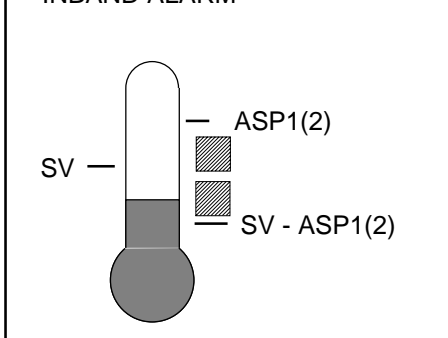
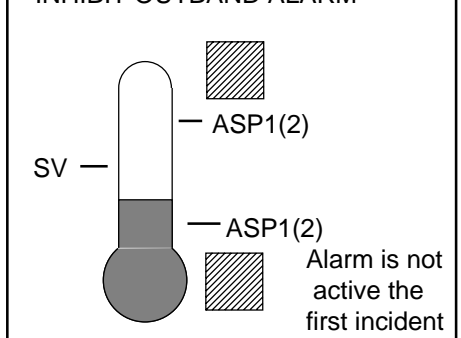
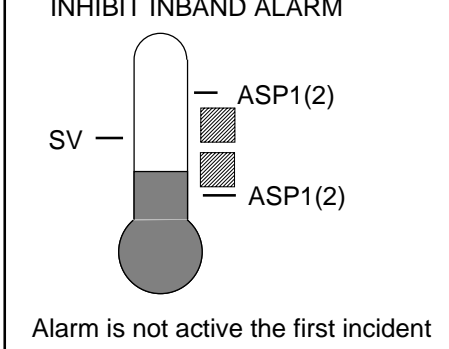
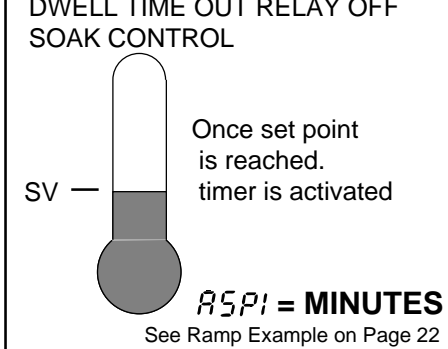
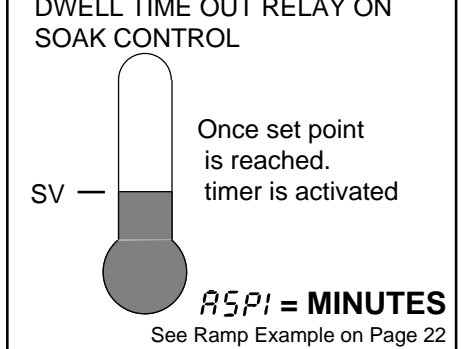
Ramp and Soak Function

The ETR-8120 and ETR-8130 can be programmed as either a fixed set point controller or as a two segment ramp and soak control. The ramp-up rate is determined by the “rr” setting. This setting can be adjusted in the range of 0-360°F (200°C) per minute. The ramp rate function is disabled if the “rr” is set to 0. The soak function is accomplished by configuring the alarm relay to act as timer. To use this function, set ALA1 to 12. The alarm relay will be closed at start-up and it will stay closed until the process temperature has remained at the set point temperature for the time period set in ASP1. The ASP1 setting is in minutes. When the alarm relay opens, the process temperature will drop at an uncontrolled rate. The heater power must be wired in series from the main relay through the alarm relay. The control will now operate as a guaranteed soak control.

Please note the following example: The ramp rate “rr” is set to 5°F per minute. The ALA1 is set to 12, and the ASP1 is set to 30 (minutes). When the unit is turned on, the process will climb at 5°F per minute to the set point of 175°F. Once the set point has been reached, the timer will activate. (After 30 minutes, the alarm relay will open, the process temperature falls.) The process will repeat every time power has been switched off and on to the controller. See Diagram 1 at right.

Single Event Function

The single event function may be used to control external devices such as lights, bells or locks. It could also be used to alert the operator when a guaranteed soak time has been reached. To use this function, set ALA1 to 13. The alarm relay will now operate as a timer. The relay will be open at start-up. Once the set point temperature has been reached and the time

period set in ASP1 has elapsed, the alarm relay will close. The relay will remain closed until power to the control has opened. The cycle will repeat each time the control is energized. Note Diagram No. 2 below.

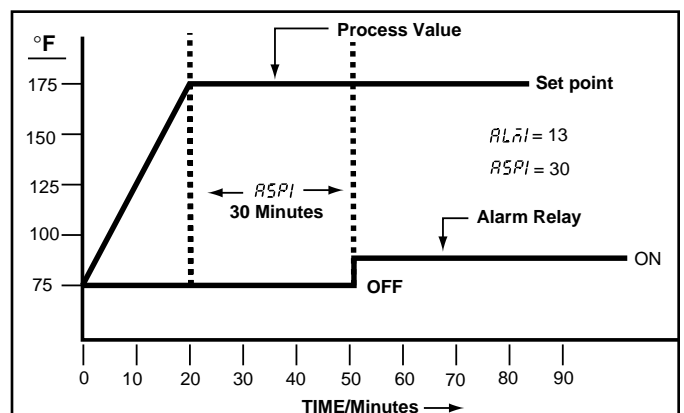
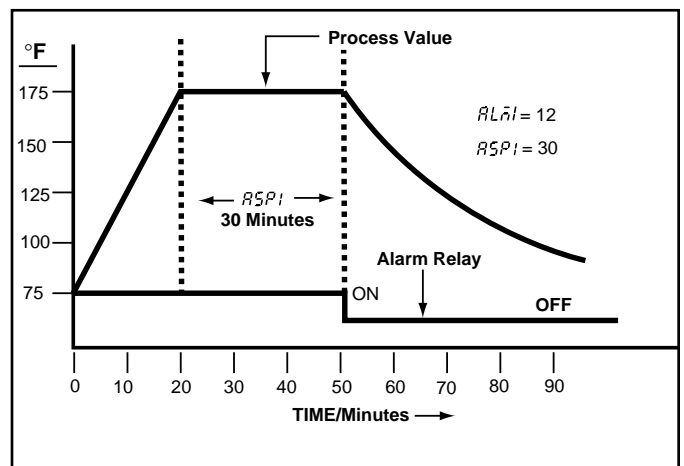

DIA. 2 Single Event

Section 7: TROUBLESHOOTING

WARNING! THIS PROCEDURE REQUIRES ACCESS TO THE CIRCUITRY OF A LIVE POWER UNIT. DANGEROUS ACCIDENTAL CONTACT WITH LINE VOLTAGE IS POSSIBLE. ONLY QUALIFIED PERSONNEL ARE TO PERFORM THESE PROCEDURES. POTENTIALLY LETHAL VOLTAGES ARE PRESENT.

Experience has proven that many control problems are not caused by a defective instrument. See chart below and Table 7.1 on the next page for some of the other common causes of failures:

- | | |
|--|----------------------------------|
| Incorrect parameters entered in menu. | Short across terminals. |
| Excessive electrical interference. | Open or shorted heater circuit. |
| Line wires are improperly connected. | Open coil in external contactor. |
| No voltage between line terminals. | Burned out line fuses. |
| Incorrect voltage between line terminals. | Burned out relay inside control. |
| Connections to terminals are open, missing or loose. | Defective solid-state relays. |
| Thermocouple (or RTD) is open at tip. | Defective line switches. |
| Thermocouple (or RTD) lead is broken. | Burned out contactor. |
| Shorted thermocouple (or RTD) leads. | Defective circuit breakers. |

If the points listed on the chart have been checked and the controller does not function, it is suggested that the instrument be returned for inspection.

Do not attempt to make repairs. Also, it is advisable to use adequate packing materials to prevent damage in shipment.

Return control to:
OGDEN MANUFACTURING COMPANY
ATTN: REPAIR DEPARTMENT
64 W. SEEGER ROAD
ARLINGTON HEIGHTS, IL 60005



Table 7.1 Troubleshooting

Symptom	Probable Cause(s)	Solution(s)
1.) LED's will not light.	—No power to instrument.	—Check power line connections.
	—Power supply defective.	—Replace power supply board.
2.) Some segments of the display or LED lamps not lit or lit erroneously.	—LED display or LED Lamp defective.	—Replace LED display or LED lamp.
	—Related LED driver defective.	—Replace the related transistor or IC chip.
3.) Process Display shows: <i>5bEr</i>	—Sensor break error.	—Replace RTD or sensor. —Use manual mode operation.
4.) Process Display shows: <i>LLEr</i>	—Process value beyond the low range setpoint.	—Re-adjust <i>LLiE</i> value.
5.) Process Display shows: <i>HLEr</i>	—Process value beyond the high range setpoint.	—Re-adjust <i>HLiE</i> value.
6.) Process Display shows: <i>REr</i>	—Analog hybrid module damage.	—Replace module. Check for outside source of damage such as transient voltage spikes.
7.) Process Display shows: <i>REr</i>	—Incorrect operation of auto tune procedure. Prop. Band set to 0.	—Repeat procedure. Increase Prop. Band to a number larger than 0.
8.) Process Display shows: <i>oPEr</i>	—Manual mode is not allowable for an ON-OFF control system.	—Increase proportional band.
9.) Process Display shows: <i>ESr</i>	—Check sum error, values in memory may have changed accidentally.	—Check and reconfigure the control parameters.
10.) Display Unstable	—Analog portion or A-D converter defective.	—Replace related components or board.
	—Thermocouple, RTD or sensor defective.	—Check thermocouple, RTD or sensor.
	—Intermittent connection of sensor wiring	—Check sensor wiring connections.
11.) Considerable error in temperature indication.	—Wrong sensor or thermocouple type. Wrong input mode selected.	—Check sensor or thermocouple type and if proper input mode was selected.
	—Analog portion A-D converter defective.	—Replace related components or board.
12.) Display goes in reverse direction (counts down scale as process warms).	—Reversed input wiring of sensor.	—Check and correct.
13.) No heat or output	—No heater power (output), incorrect output device used.	—Check output wiring and output device.
	—Output device defective.	—Replace output device.
	—Open fuse outside of the instrument.	—Replace output fuse.
14.) Heat or output stays on but indicator reads normal.	—Output device shorted, or power service shorted.	—Check and replace.
15.) Control abnormal or operation incorrect.	—CPU or EEPROM (non-volatile memory) defective. Key switch defective.	—Check and replace.
	—Operation of control incorrect.	—Read the operation procedure carefully.
16.) Display blinks, entered values change by themselves.	—Electromagnetic interference (EMI), or Radio Frequency Interface (RFI).	—Suppress arcing contacts in system to eliminate high voltage spike sources. Separate sensor and controller wiring from "dirty" power lines, ground heaters.
	—EEPROM defective.	—Replace EEPROM.