

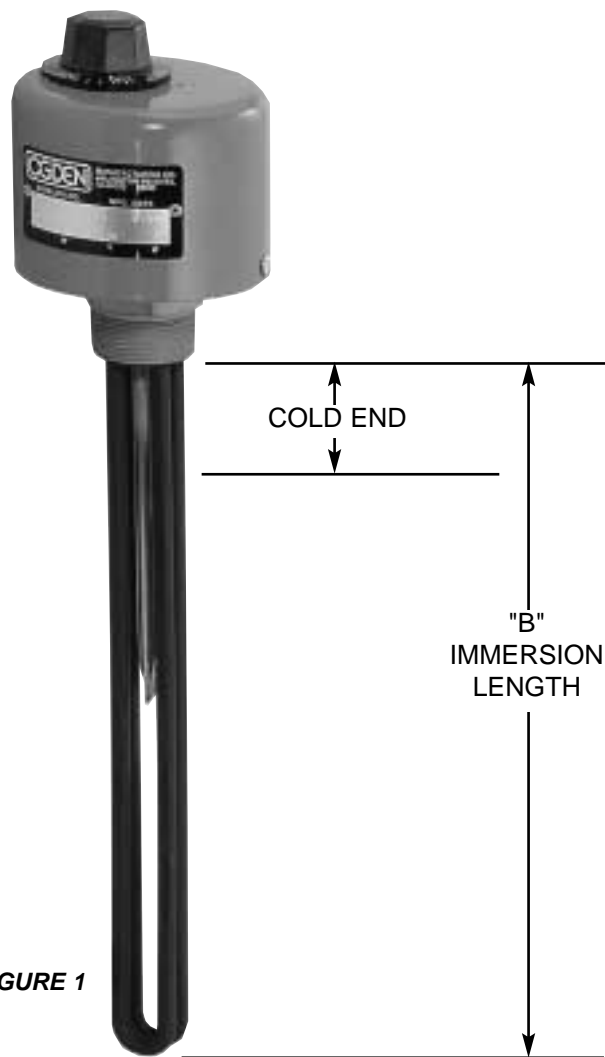

INSTALLATION AND OPERATION INSTRUCTIONS FOR OGDEN PIPE PLUG IMMERSION HEATERS



PIPE PLUG SIZE	COLD END
1" NPT	1"
1¼" NPT	1"
2" NPT	2"
2½" NPT	2"

FIGURE 1

READ AND FOLLOW ALL INSTRUCTIONS

BEFORE INSTALLING:

1. Unpack the heater at the place of installation. Inspect the heater for shipping damage and report any claims to the carrier. **Do not operate damaged equipment.** Consult OGDEN for instructions.
2. Check the nameplate watt and volt rating against your supply voltage and capacity and the requirements of your installation.

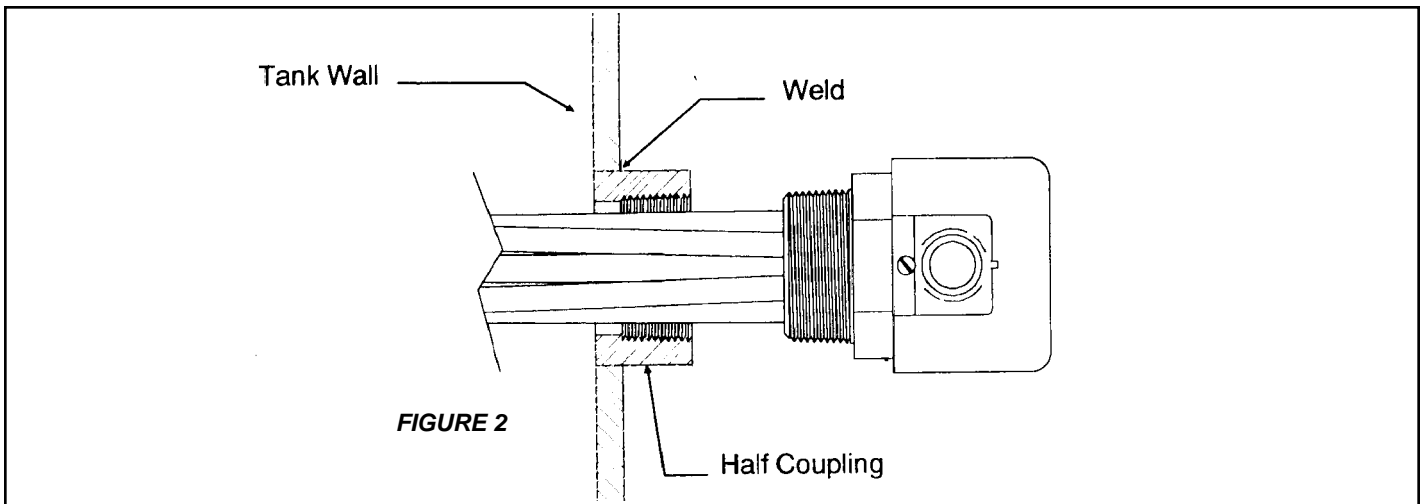

INSTALLATION INSTRUCTIONS

MOUNTING (FIGURE 2)

1. The heater must be installed so that the heated section is immersed at all times. Premature failure of the element will occur if this is not done.
2. Horizontal mounting of the heater is recommended.
3. The heater should be located as close to the bottom of the tank as possible for maximum heating efficiency.
4. Locate the heater below the minimum liquid level and above the maximum expected sludge level. (Figure 3.)
5. Cover the threads of screw plug immersion heaters with teflon tape or sealing compound before installing.
6. Use a wrench on the hex portion of screw plug to tighten the heater in the threaded tank opening. **Do not** turn the heater by the terminal enclosure.

WIRING

1. All wiring should be done in accordance with the National Electrical Code and applicable local codes.
2. Refer to the wiring diagrams on the back page of this manual for the proper method of connecting the heater.
3. The current carrying capacity of the power supply leads should exceed the heater amperage by at least 25%. Be sure to consider the ambient operating temperature and apply the appropriate correction factor to the ampacity rating of the wire. Lead wire used must be rated for 150°C minimum.

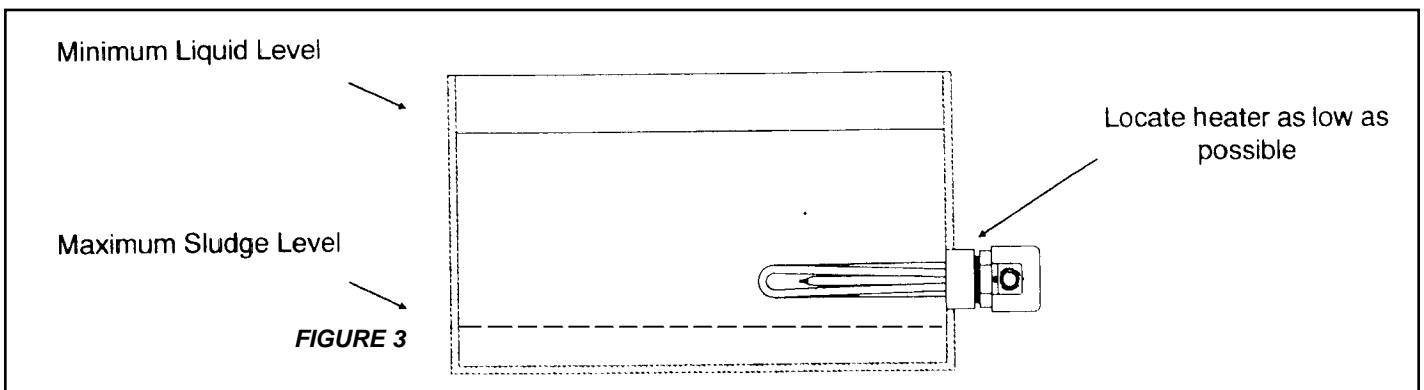

THERMOSTATS

1. Integrally mounted thermostats are designated as "T1" for single pole, single throw models and as "T2" for double pole, single throw models.
2. Electrical rating of thermostats:
3. Thermostats may be connected directly to heaters that are

Voltage	Thermostat Type	
	T1	T2
120	25 Amps	30 Amps
240	25 Amps	30 Amps
480	N/A	21 Amps

rated within the electrical capacities specified above. When the heater amperage exceeds the contact rating of the thermostat, the heater should be controlled by a magnetic contactor with the thermostat wired for pilot duty. Refer to the wiring diagram packed with the heater.

BEFORE ENERGIZING

1. Check that the pipe plug is properly sealed and screwed tightly into the coupling.
2. Check that power supply connections are made according to the wiring diagram. Also check for positive connection of all bus bars and power supply leads.
3. The insulation material used in electric heaters may absorb moisture during shipping, while in storage or when subjected to a humid environment. Because this moisture can lead to eventual failure of the heater, it is recommended that the heater be subjected to a high potential test and/or checked with a megohmmeter before energizing. A test voltage of 1000 volts plus twice the rated voltage should be used for the hi-pot test. [ex.: heater voltage = 480V, Test voltage = $1000V + (2 \times 480V) = 1960V$]. A reading of 50 megohms or greater can be considered acceptable if checking insulation resistance.
4. If a moisture condition exists, it can be corrected by removing the terminal hardware and baking the heater in an oven at 350°F to 500°F for several hours. If the heater is too large or an oven is not available, an alternative method is to energize the heater at half voltage for 15 minutes, repeating heating cycles as required. The first procedure is preferred and particularly recommended if the heater has long cold ends and/or a low watt density.

OPERATION AND MAINTENANCE

1. Do not operate the heater unless it is completely immersed.
2. Do not bend the elements. Consult OGDEN if bending is necessary.
3. The heater can be protected from possible mechanical damage by placing a screen or grill around the elements.

4. Protect the terminal end of the heater from spray, condensation, dripping and vapors. A protective terminal enclosure should be used if the heater is to be subjected to these conditions.
5. If the heater is to be operated in the presence of explosive vapors or dust, an explosion resistant terminal enclosure must be provided.
6. Do not set the thermostats above the boiling point of the liquid. The boiling liquid could create a steam pocket which could cause the element(s) to overheat and burn out.
7. Periodically, remove the heater from the tank to inspect the elements for signs of corrosion and remove any deposits from the sheath. **BE SURE POWER IS DISCONNECTED BEFORE REMOVING ELEMENTS.**
8. Be sure the sheath material is compatible with the material being heated. Copper sheathed elements are used to heat oil, alkaline, wax and other similar materials. Stainless steel and Incoloy sheathed elements are most often used for heating water and corrosive solutions. Check with the supplier of the material or OGDEN for a recommendation of a suitable sheath material.
9. Make sure the watt-density of the heater is suitable for the material being heated. The velocity, viscosity, thermal conductivity of the material and operating temperature are all factors in determining the allowable watt-density of the element. Consult OGDEN if in doubt about the proper watt-density for the heater in a particular application.
10. When heating liquids in a large tank, the use of several small heaters will provide more uniform heat distribution than a single large heater.

Special Requirements for Electric Heaters and Terminal Enclosures in Hazardous Locations:

Wiring - The proper use of Type M6 and M7 terminal enclosures on electric heaters located in hazardous areas requires that all electrical wiring comply with National Electrical Code (NEC) requirements for hazardous locations.

Maximum Temperatures - Safe operation in a hazardous location requires the maximum operating temperatures of all exposed surfaces of the heater including temperatures on the outside of the vessel, piping, flanges, screw plugs, enclosures and other heat conducting parts be limited. The flammable liquids, vapors or gases present determine the maximum surface temperature permitted in any hazardous location. The end user or purchaser of the electric heating equipment is responsible for determining the proper classification of an area and for providing Ogden Mfg. Co. with hazardous area specifications and requirements for proper equipment design. (NEC Articles 500 and 501 provide guidelines for evaluating and classifying hazardous locations.)

Safety Devices - Approved pressure and/or temperature limiting controls must be used on electric heaters and heating elements to ensure safe operation in the event of system malfunctions.

Note 1 - Class I Group B locations include Hydrogen gas. These areas require additional conduit seals and thread engagement.

TYPICAL WIRING DIAGRAMS

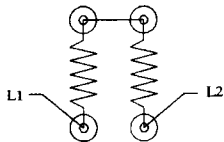

1 Phase, Series

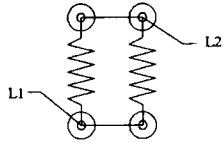

1 Phase, Parallel

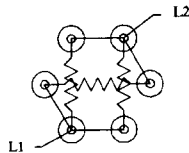

1 Phase

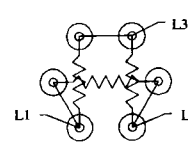

3 Phase Delta

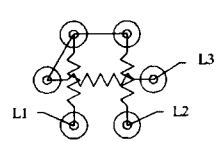

3 Phase Y

1 1/4" & 2" Pipe Plugs, 2 Elements

2" Pipe Plugs, 3 Elements

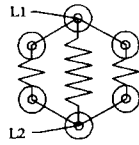

1 Phase

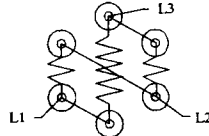

3 Phase Delta

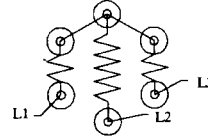

3 Phase Y

2 1/2" Pipe Plugs, 3 Elements

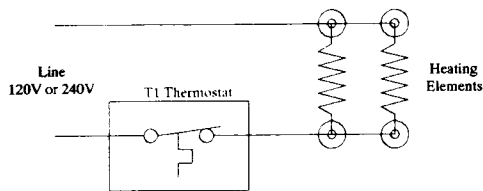

Single Phase

Maximum Rating 3000W @ 120V, 6000W @ 240V

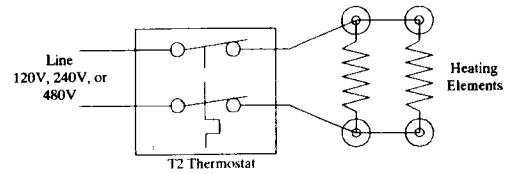

Single Phase

Maximum Rating 3.6KW @ 120V, 7.2KW @ 240V, 10KW @ 480V

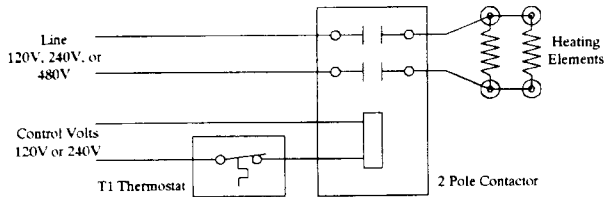

Single Phase

For 120V, 240V or 480V heaters when current exceeds thermostat rating

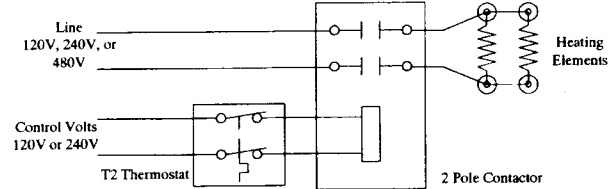

Single Phase

For 120V, 240V or 480V heaters when current exceeds thermostat rating

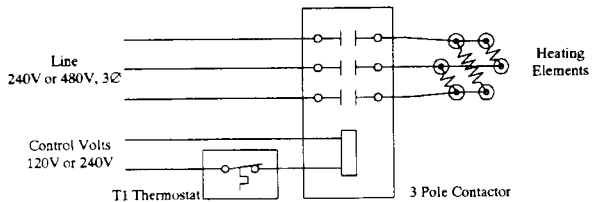

All 3 Phase Heaters

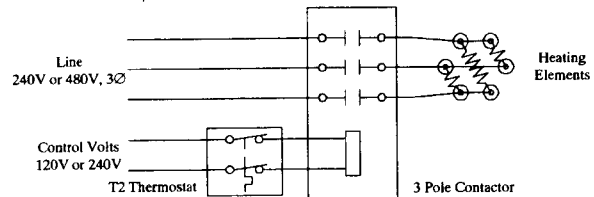

All 3 Phase Heaters



64 West Seegers Road, Arlington Heights, IL 60005
 Phone: 847-593-8050 • Fax: 847-593-8062
 www.ogdenmfg.com

2002
 OGDEN is a Registered Trademark of
 Ogdan Manufacturing Co.
 MARCA REGISTRADA