

INTRODUCTION

Vaisala's GMD20/D transmitters use a completely new CO₂ sensor technology. The silicon based CARBOCAP[®] sensor provides for excellent stability and reliability. The GMD20/D transmitters require almost no maintenance: the recommended calibration interval is five years in HVAC and related benign applications. This combined with the high performance makes the GMD20/D transmitters an extremely attractive choice for various applications.

MOUNTING

The GMD20/D transmitters are truly duct mounted. The distance between the probe and the duct wall is easily adjusted using the mounting plate. The mounting plate is fastened with four screws ST.4.2x16-C-Z/A4m DIN 7981. Note that four Ø3.2 holes on the duct surface are needed, as well as one Ø22...25 mm hole in the middle (see figure below). Insert the transmitter through the mounting plate and adjust the distance.

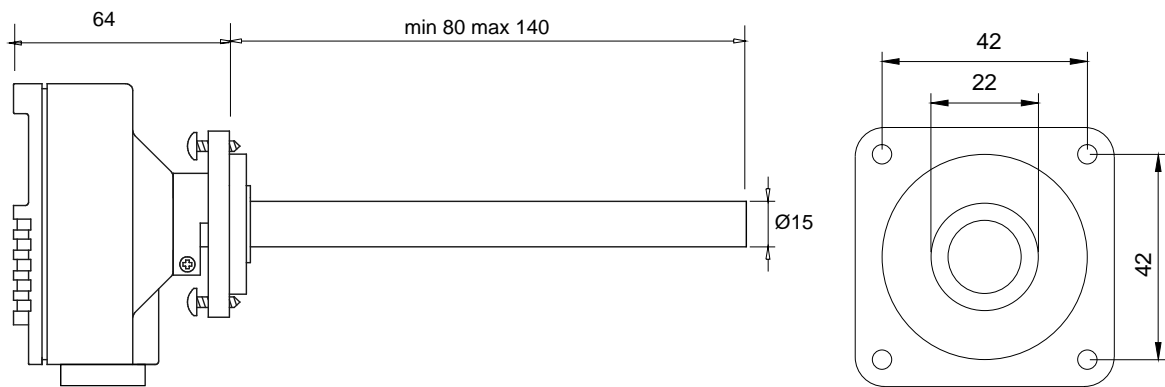

Figure 1 Dimensions of the GMD20/D and the mounting plate(in mm)

ELECTRICAL CONNECTIONS

Open the transmitter cover and remove the display board if there is one installed. The cable is inserted through a rubber plug included in the package. Pierce the rubber plug with a screwdriver or a similar instrument in order to open the hole for the cable. Then insert the plug in the appropriate hole in the transmitter cover. Strip a few millimetres of the cable insulation and insert the cable carefully through the rubber plug so that you can connect the wires to the terminal block on the righthand side of the component board.

The nominal 24 V supply must be connected between terminals + and -. The analogue output is available at remaining

terminals. The common wire is connected to terminal 0 and the other wire either to terminal V (voltage output) or to terminal mA (current output). The current output type is chosen with the jumper 0/4mA (see Figure 2): 4...20mA is chosen by connecting the jumper (default) and the 0...20 mA is chosen by disconnecting the jumper. If the relay output of the display board (in GMD20D only) is used, connect the wires to the terminal block at the back of the display board before re-installing it. The default relay trigger point has been set to 1000 ppm and it can be changed with the optional software kit 19222GM. For further details, contact your local Vaisala representative. If an optional LonWorks interface or a relay output is installed in

the GMD20, please, refer to the corresponding manuals for details.

Note that during normal operation the green led (V10) at the lower righthand corner is blinking. In case the self-diagnostics procedure comes across some abnormality, the red led (V7) lights up (see Figure 2).

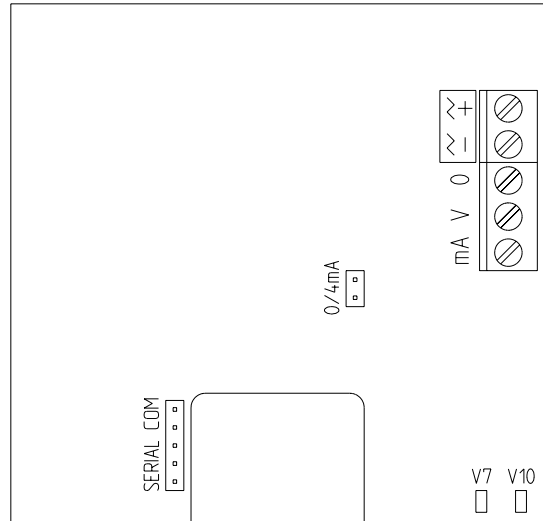

Figure 2 Electrical connections and leds V7, V10

SERVICE AND MAINTENANCE

The GMD20/D transmitters have an excellent stability and require almost no maintenance. In benign environments the recommended calibration interval is five years. Users who prefer checking the calibration every now and then on-site, are able to do it easily and conveniently with Vaisala's portable CO₂ meter and the GM35001 calibration pipe.

If the reading differs too much from the reference value during checking, the transmitter should be removed and preferably sent to Vaisala or Vaisala distributor for re-calibration. In case the user prefers to do the re-calibration himself, Vaisala's software Kit 19222GM and accurate calibration gases are needed.

If full accuracy is required, the transmitter has to be calibrated against accurate and traceable calibration gases in stable environmental conditions (temperature, pressure). Accurate calibrations are usually performed in laboratories; in these calibrations, temperature and pressure corrections have to be made. A full after sales calibration and service facility is naturally provided by Vaisala and its

distributors. For further details, consult your local Vaisala representative.

POWER SUPPLY REQUIREMENTS

The GMD20/D transmitter is designed to operate from a nominal 24 VAC/VDC supply. The power supply should maintain the voltage between 18...30 VDC or 20...26 VAC for all load conditions and all mains voltages. The power input includes a halfwave rectifier. To avoid current peaks, it is recommended to use a DC supply. The average transmitter current consumption is 85 mA maximum but peak currents of 170 mA may occur during normal operation.

CONNECTION TO A 24 VAC SUPPLY

The GMD20/D transmitters can also be connected to a 24 VAC supply without an external rectifier. However, when more than one transmitter is connected to one 24 VAC transformer, a common loop

is formed and there is an increased risk of a short-circuit. To avoid this, always use separate floating supply for each transmitter (see Figure 3A). However, if several transmitters have to share one transformer, the phase (~) must always be connected to + connector in each transmitter (see Figure 3B).

A) NO COMMON LOOP FORMED - RECOMMENDED

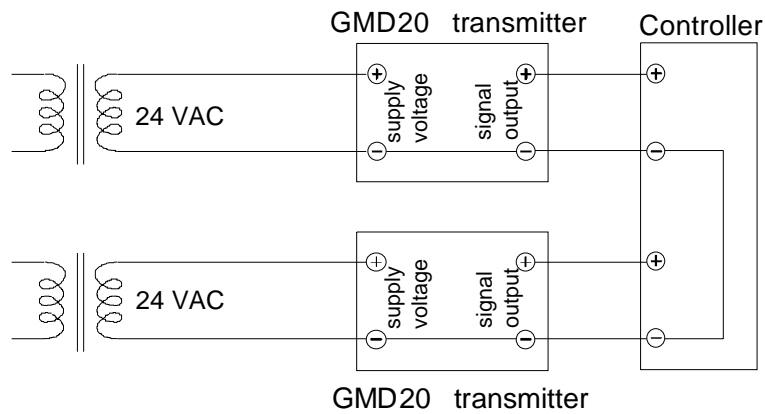

B) COMMON LOOP FORMED - NOT RECOMMENDED!

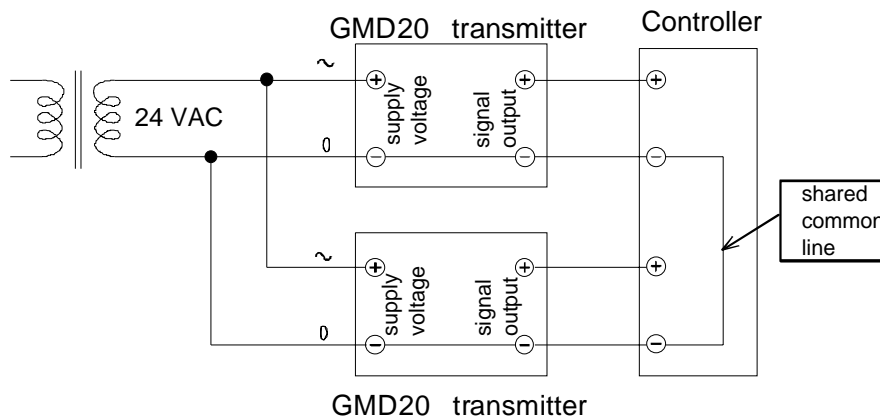

Figure 3 AC connections

TECHNICAL DATA
Carbon dioxide

Measuring range	0-2000 ppm CO ₂ (nominal); with recalibration 0-5000 ppm, 0-10 000 ppm, 0-20 000 ppm
Accuracy at 20°C against certified factory references (including non-linearity and calibration uncertainty)	<±[1 %FS + 1.5% of the reading]
Repeatability	<±1 %FS
Temperature dependence of output	< 0.05 %FS / °C
Long-term stability	<±5 %FS / 5 years
Response time (0...63%)	1 minute

Operating conditions

Operating temperature	-5...+45 °C
Storage temperature	-20...+70 °C
Humidity range	short term 0...100 %RH (non-condensing) long term 0...85 % RH
Air flow range	0...10 m/s

General

Analogue outputs	0...20 mA or 4...20 mA and 0...10 V
Recommended external load:	
current output	max. 500 Ω
voltage output	min. 1kΩ
Relay contact ratings	max. 50 V 0.5 A
Power supply	nominal 24 VDC/VAC (18...30 VDC)
Power consumption	< 2.5 W average
Warm-up time	< 5 minutes

Mechanics

Housing material	ABS plastic
Housing classification (electronics housing)	IP65
Weight:	
GMD20	140 g
GMD20D	170 g

Accessories

Order code	Description
GMR20	Relay output option (GMD20 only)
GML20	LonWorks [®] interface option (GMD20 only)
GM35001	Calibration pipe
GM12	Portable CO ₂ meter
18192GM	Field calibration kit (used with Vaisala's portable CO ₂ meters)
19222GM	Calibration software kit (incl. disk and serial COM adapter)

GUARANTEE

Vaisala issues a guarantee for the material and workmanship of this product under normal operating conditions for one (1) year from the date of delivery. Exceptional operating conditions, damage due to careless handling and misapplication will void the guarantee.