

HMP230 Humidity and Temperature Transmitters



Versatile Humidity Transmitters for Demanding Users

There are many diverse industrial processes which all make their own demands on the instrumentation used.

Ideally such instruments should be easy to install, use and maintain, stable, completely reliable and at the same time they must measure the process accurately. With these requirements in mind Vaisala's HMP230 series humidity transmitters provide a flexible solution for various industrial applications.

The HMP230 series of humidity and temperature transmitters have been designed for use in demanding applications where humidity control is important.

Applications include industrial control (such as drying processes), demanding air-conditioning in special environments as well as storage and warehouse areas.

The transmitters' accuracy, flexibility and interfacing options also make them suitable for laboratory measurements, where special parameters are required and the settings may need to be changed regularly.

HUMICAP® PERFORMANCE

All five HMP230 transmitters incorporate the latest version of the HUMICAP® humidity sensor.

The HUMICAP® sensor is accurate, reliable and has excellent long-term stability within the whole measurement range. The sensor is immune to particulate contamination and most chemicals and can be used with confidence in industrial environments.

The re-gaining option makes the HMP230 transmitters accurate and stable even in environments where high concentration of chemicals or cleaning agents are present helping to maintain measurement accuracy between calibrations.

In re-gaining the performance of the sensor is returned to normal by evaporating the chemicals from the sensor. This re-gaining can be made using a software command or it can be programmed to occur at set intervals.



HUMICAP humidity sensors

Five Models for Different Applications



FIVE MODELS

There are altogether five types of transmitters in the HMP230 series providing a solution even for the toughest applications.

The **HMP231** is suitable for **wall mounting** for a temperature range of -40...+60 °C.

The four other models – HMP233, HMP234, HMP235 and HMP238 – have separate sensor heads at the

end of a cable: they can be located directly in the process which improves measurement reliability significantly.

In the **HMP233** the sensor head is small and **fits into tight spaces**. It can be fitted with two different cables; one is for lower temperatures up to +80 °C and the other can be used in temperatures up to +120 °C.

The **HMP234** is designed specially for measurement in **pressurized spaces** or vacuum chambers; its pressure range goes from vacuum to as high as 100 bar (10 MPa). In addition to this, it withstands temperatures up to +180 °C.

The **HMP235** is designed for **high temperatures**; the sensor head can be used in temperatures as high as +180 °C.

The **HMP238** enables **flexible installations in pressurized pipelines** to as high as 40 bar (4 MPa).

Reliability & Flexibility

CONFIGURED TO YOUR REQUIREMENTS

The HMP230 transmitters are extremely flexible products which can be configured in many ways – both in hardware and software. They are manufactured on a production line where they are configured to the customer requirements. The user does not need to change any transmitter settings when installing the instrument unless the application has changed in some way. If so, the settings of the HMP230 transmitters are easy to change even in the field.

SETTINGS AND ADJUSTMENTS MADE EASY

The HMP230 transmitters have several output variables to choose from. They, like the other settings, are easy to change. Selecting, scaling and calibrating the analogue output signals and parameters can be done in a few minutes using simple software commands.

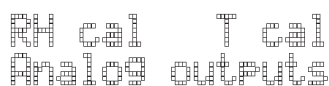

RH cal T cal
Analog outputs

This can be done by using the menus on the local display or with a PC or terminal connected to the transmitters' serial bus.

The microprocessor-based transmitters **measure the relative humidity and temperature**. From these two measurements other variables – dewpoint temperature, wet bulb temperature, absolute humidity, mixing ratio and enthalpy – can be calculated depending on the transmitter version. The transmitters have two analogue output channels and any two of the seven measured or calculated variables can be selected as output signals.

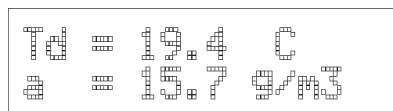

Td = 19.4 C
a = 15.7 g/m3

The measurement ranges and the output signals can be selected and scaled within certain limits which depend on the maximum measurement range. For example, the standard temperature measurement range of the HMP235 is -40...+180 °C, but it can easily be scaled so that -20...+100 °C corresponds to 0...20 mA or any other output signal.

CALIBRATION

The transmitter software also includes a procedure for calibrating the relative humidity and temperature. The calibration can be done either by making a fast one-point adjustment in the field against a reliable reference instrument, such as Vaisala's humidity data processor HMI38, or a two-point calibration in a controlled environment e.g. with a salt bath calibrator such as Vaisala's HMK15 calibrator.

The calibration interval depends on the application where the transmitter is used. In normal conditions calibration once year is recommended.

TRANSMITTER PROTECTION

The housing of the HMP230 transmitters is made of aluminium which provides IP 65 protection from dust and sprayed water.

The housing also provides protection from electromagnetic interference. The cables used are all protected from electromagnetic interference either to 3 V/m or 10 V/m. However, the electromagnetic compatibility of the sensor heads depends on the filters fitted. See General Technical Information for all cable/filter combinations.

Options



The transmitters are available with a display/keypad cover as well as several connector options

INSTALLATION OPTIONS

The sensor head of the **HMP233** transmitter is ideal for use in tight spaces, but it can also be installed in ducts and chambers or even on walls with the help of an installation kit. The kit consists of a flange and a supporting bar for the sensor head cable; using this kit the distance between the sensor head and the channel or duct wall can be easily adjusted.

The installation of the **HMP235** can be made easier with an optional mounting flange of aluminium or stainless steel. The steel flange is recommended for applications where the conditions require more hard-wearing materials.

The **HMP238** can be ordered with a ball valve set that enables disconnecting and re-installing the moisture probe for calibration for example without the need to interrupt the process.

CABLES

The cables of the HMP233, HMP234, HMP235 and HMP238 can be either two, five or ten metres long. The HMP233 is available with two types of cable: one for temperatures up to +80 °C, the other for temperatures up to +120 °C.

COVER

The transmitters can be supplied with a cover which has a **local display/keypad**. The display shows the measurement readings and also functions as a user interface.

A display/keypad transmitter is easy to use and configure with the menu-based commands of the built-in software. A basic transmitter without the display option is operated by using three press switches inside the cover.

SENSOR PROTECTION

The HMP230 sensors can be protected with three types of filter:

- stainless steel sintered filter (part no. 16452)
- PPS grid with stainless steel netting (part no. 16720)
- PPS grid (part no. 16562)

A sintered filter is recommended when the sensor head needs protection against mechanical shocks; otherwise a steel netting filter is sufficient. The open PPS (polyphenyl sulphide) grid should only be used in clean environments where a short response time is important. All the filters can tolerate temperatures up to +180 °C.

When the transmitter has a composite sensor for re-gaining, either the PPS grid with steel netting or sintered filter must be used.

POWER SUPPLY MODULE

Standard HMP230 transmitters are powered with 24 VDC or VAC. With the power supply module, the HMP233, HMP234, HMP235 and the HMP238 transmitters can also be used with 115 VAC or 230 VAC supplies. The module is installed inside the transmitter housing.

ALARM RELAYS

For applications where adjustable on/off alarm control is needed the alarm relay option is the solution. Alarm relays include two SPCO (single pole change over) type relays with 8A /230V contacts. They are easy to adjust with a display keypad or through RS 232. This option is available for the HMP233, HMP234, HMP235 and HMP238 transmitters.

CONNECTORS

The transmitters have several different connector options for analogue output signals, supply voltage (24 VAC/VDC) and RS lines (RS 232C/422/485) (see Technical Information on page 6). The connectors have the EMC and IP65 protection as well as easy screw connections.

Technical Information

MEASURED VARIABLES

Relative humidity

Measurement range 0...100 %RH

Accuracy (including nonlinearity and repeatability)

when calibrated against salt solutions (ASTM E104-85):

±2 %RH (0...90 %RH)

±3 %RH (90...100 %RH)

maximum achievable accuracy when calibrated against

high-quality, certified humidity standards:

±1 %RH (0...90 %RH)

±2 %RH (90...100 %RH)

Response time (90 %) at +20 °C

in still air (with sintered filter)

15 s

Humidity sensor

HUMICAP® sensor

Temperature

Measurement range

HMP231 -40...+60 °C

HMP233 -40...+80 °C or -40...+120 °C

HMP234, HMP235 & HMP238 -40...+180 °C

Typical accuracy of electronics at +20 °C

±0.1 °C

Typical temperature dependence

±0.005 °C/°C

of electronics

Temperature sensor

Pt 100 IEC 751 1/3 class B

CALCULATED VARIABLES (DEPENDS ON MODEL TYPE)

Typical ranges

HMP231

dewpoint temperature -40...+60 °C

mixing ratio 0...160 g/kg d.a.

absolute humidity 0...160 g/m³

wet bulb temperature 0...+60 °C

enthalpy -40...+460 kJ/kg

HMP233, HMP234, HMP235 & HMP238

dewpoint temperature -40...+100 °C

mixing ratio 0...500 g/kg d.a.

absolute humidity 0...600 g/m³

wet bulb temperature 0...+100 °C

enthalpy -40...+1500 kJ/kg

CONNECTORS

Vs = power supply

ao = analog outputs

24 POWER SUPPLY	Analog outputs	Power supply	Serial interface	Alarm output
no connectors	shared cable	shared cable	shared cable	-
no connectors, alarm output unit	shared cable	shared cable	shared cable	cable
shared connector for Vs and ao	shared connector		-	-
as above but with the alarm output unit	shared connector		-	cable
connector for the RS232C	shared cable	shared cable	connector	-
2 connectors: RS232C and ao + Vs	shared connector		connector	-
2 connectors: shared for RS485 and Vs	-	shared connector		-
115/230 V POWER SUPPLY	Analog outputs	Power supply	Serial interface	Alarm output
no connectors	shared cable	cable	shared cable	-
connector for ao	connector	cable	-	-

ACCURACIES OF THE VARIABLES

Accuracies of the calculated variables depend on the calibration accuracy of the humidity and temperature sensors; here the accuracies are given for ±2 %RH and ±0.2 °C.

Temp.	Relative humidity									
	10	20	30	40	50	60	70	80	90	100
-40	1.86	1.03	0.76	0.63	0.55	0.50	0.46	0.43	—	—
-20	2.18	1.19	0.88	0.72	0.62	0.56	0.51	0.48	—	—
0	2.51	1.37	1.00	0.81	0.70	0.63	0.57	0.53	0.50	0.48
20	2.87	1.56	1.13	0.92	0.79	0.70	0.64	0.59	0.55	0.53
40	3.24	1.76	1.27	1.03	0.88	0.78	0.71	0.65	0.61	0.58
60	3.60	1.96	1.42	1.14	0.97	0.86	0.78	0.72	0.67	0.64
80	4.01	2.18	1.58	1.27	1.08	0.95	0.86	0.79	0.74	0.70
100	4.42	2.41	1.74	1.40	1.19	1.05	0.95	0.87	0.81	0.76
120	4.86	2.66	1.92	1.54	1.31	1.16	1.04	0.96	0.89	0.84
140	5.31	2.91	2.10	1.69	1.44	1.26	1.14	1.05	0.97	0.91
160	5.80	3.18	2.30	1.85	1.57	1.38	1.24	1.14	1.06	0.99

Accuracies of mixing ratio g/kg (ambient pressure 1013 mbar)

Temp.	Relative humidity									
	10	20	30	40	50	60	70	80	90	100
-40	0.003	0.003	0.003	0.003	0.003	0.004	0.004	0.004	—	—
-20	0.017	0.018	0.019	0.021	0.022	0.023	0.025	0.026	—	—
0	0.08	0.09	0.09	0.10	0.10	0.11	0.11	0.12	0.13	0.13
20	0.31	0.33	0.35	0.37	0.39	0.41	0.43	0.45	0.47	0.49
40	0.97	1.03	1.10	1.17	1.24	1.31	1.38	1.46	1.54	1.62
60	2.68	2.91	3.16	3.43	3.72	4.04	4.38	4.75	5.15	5.58
80	6.73	7.73	8.92	10.34	12.05	14.14	16.71	19.92	24.01	29.29
100	16.26	21.34	28.89	40.75	60.86	98.85	183.66	438.56	—	—
120	40.83	74.66	172.36	—	—	—	—	—	—	—

Accuracies of wet bulb temperature °C (ambient pressure 1013 mbar)

Temp.	Relative humidity									
	10	20	30	40	50	60	70	80	90	100
-40	0.20	0.20	0.20	0.20	0.20	0.20	0.20	0.20	—	—
-20	0.21	0.21	0.22	0.22	0.22	0.22	0.23	0.23	—	—
0	0.27	0.28	0.28	0.29	0.29	0.29	0.30	0.30	0.31	0.31
20	0.45	0.45	0.45	0.44	0.44	0.44	0.43	0.43	0.42	0.42
40	0.84	0.77	0.72	0.67	0.64	0.61	0.58	0.56	0.54	0.52
60	1.45	1.20	1.03	0.91	0.83	0.76	0.71	0.67	0.63	0.60
80	2.23	1.64	1.32	1.13	0.99	0.89	0.82	0.76	0.72	0.68
100	3.06	2.04	1.58	1.31	1.14	1.01	0.92	0.85	0.80	0.75
120	3.85	2.40	1.81	1.48	1.28	1.13	1.03	0.95	0.88	0.83
140	4.57	2.73	2.03	1.65	1.41	1.25	1.13	1.04	0.97	0.91
160	5.25	3.06	2.25	1.82	1.55	1.37	1.24	1.13	1.05	0.99

Accuracies of absolute humidity g/m³

Temp.	Relative humidity									
	10	20	30	40	50	60	70	80	90	100
-40	0.004	0.004	0.005	0.005	0.005	0.006	0.006	0.006	—	—
-20	0.023	0.025	0.027	0.029	0.031	0.032	0.034	0.036	—	—
0	0.10	0.11	0.12	0.13	0.13	0.14	0.15	0.15	0.16	0.17
20	0.37	0.39	0.41	0.43	0.45	0.47	0.49	0.51	0.53	0.55
40	1.08	1.13	1.18	1.24	1.29	1.34	1.39	1.44	1.49	1.54
60	2.73	2.84	2.95	3.07	3.18	3.29	3.40	3.52	3.63	3.74
80	6.08	6.30	6.51	6.73	6.95	7.17	7.39	7.61	7.83	8.05
100	12.2	12.6	13.0	13.4	13.8	14.2	14.6	15.0	15.3	15.7
120	22.6	23.3	23.9	24.6	25.2	25.8	26.5	27.1	27.8	28.4
140	39.1	40.0	41.0	42.0	43.0	44.0	45.0	45.9	46.9	47.9
160	63.5	64.9	66.4	67.8	69.2	70.7	72.1	73.5	74.9	76.4

Accuracies of enthalpy kJ/kg (ambient pressure 1013 mbar)

Temp.	Relative humidity									
	10	20	30	40	50	60	70	80	90	100
-40	0.21	0.21	0.21	0.21	0.21	0.21	0.21	0.21	—	—
-20	0.24	0.25	0.25	0.25	0.26	0.26	0.26	0.27	—	—
0	0.4	0.42	0.43	0.45	0.46	0.47	0.49	0.5	0.52	0.53
20	0.98	1.03	1.08	1.13	1.18	1.23	1.29	1.34	1.39	1.45
40	2.7	2.87	3.04	3.22	3.4	3.59	3.78	3.98	4.18	4.39
60	7.2	7.82	8.48	9.19	9.96	10.79	11.69	12.65	13.7	14.84
80	18.04	20.72	23.88	27.66	32.22	37.77	44.61	53.17	64.02	78.06
100	43.96	57.64	77.98	109.93	164.1	266.37	494.62	1180.46	—	—
120	111.6	203.93	470.52	—	—	—	—	—	—	—

Technical Information

OUTPUTS

Two analogue outputs selectable and scaleable	0...20 mA 4...20 mA 0...1 V 0...5 V 0...10 V
Typical accuracy of analogue output at +20 °C	±0.05 % full scale
Typical temperature dependence of analogue output	0.005 % full scale/°C
Serial output available	RS 232C

GENERAL

Connections	screw terminals for 0.5 mm ² wires (AWG 20), stranded wires recommended
Operating voltage	24 VDC/isolated 24 VAC (20...28 V)
option	115 VAC, 230 VAC
Power consumption	
without alarm relays	100 mA max. (24 VDC)
during re-gaining	170 mA max. (24 VDC)
of the alarm relays	55 mA max. (24 VDC)
Recommended external load for current outputs	< 500 ohm
0...1 V output	> 2 kohm (to ground)
0...5 & 0...10 V outputs	> 10 kohm (to ground)
Operating temperature range for electronics	-40...+60 °C
with display cover	0...+50 °C
with power supply unit	-40...+45 °C
with alarm outputs up to 8A	-40...+40 °C
up to 6A	-40...+60 °C
Storage temperature range	-40...+70 °C
Pressure range of	
HMP234	0...10 MPa (0...100 bar)
HMP238	0...4 MPa (0...40 bar)
	absolute pressure
Housing material	G-ALSi12 (DIN 1725)
Housing classification	IP 65 (NEMA 4)
Bushing	for 7...10 mm diameter cables (8 x 0.5 mm ² shielded cable)

Electromagnetic compatibility - filter types

	sintered	PPS grid with steel netting	PPS grid
HMP231	EMC	EMC	emc
HMP233/ +80 °C cable	emc	emc	emc
HMP233/+120 °C cable	emc	EMC	emc
HMP234	EMC	emc	emc
HMP235	EMC	EMC	emc
HMP238	EMC	not available	emc

EMC = fully electromagnetically compatible: IEC 801-3, 10 V/m
emc = electromagnetically compatible: IEC 801-3, 3 V/m

OPTIONS

Output variables — depend on model type	
measured	relative humidity temperature
calculated	dewpoint temperature mixing ratio absolute humidity wet bulb temperature enthalpy
Sensor re-gaining	composite RH+T sensor
Cover	local display/keypad
display	2 x 16 characters' LCD
Filters	sintered filter of stainless steel PPS grid with steel netting PPS grid
Cable lengths	2, 5 or 10 metres
HMP233	+80 or +120 °C cable
HMP234, HMP235 & HMP238	+180 °C cable
Alarm relays*	2 relays 8A / 230VAC/24 VDC SPCO
Installation flanges	aluminium and stainless steel
for the HMP235	
Installation kits	duct mounting installation
for the HMP233	kits for +80 and +120 °C cables

POWER SUPPLY MODULE*

Operating voltage	115 VAC (93...127 V) 230 VAC (187...253 V)
Connections	
input	screw terminal for 1.5 mm ² wires (AWG 16)
output	screw terminal for 0.5 mm ² wires (AWG 20)
The power supply module can not be used when the sensor re-gaining option is included in the transmitter.	

SERIAL INTERFACE MODULES

Module types	RS 485/422 digital current loop
Connections	screw terminals for 0.5 mm ² wires (AWG 20), stranded wires recommended plug-in module
Assembly	
Number of devices on line	32
RS 485/422	
digital current loop	6 (single loop) or 9 (dual loop)
Network cable type	twisted pair
Network line length	1000 m max.
Network data speed	
RS 485/RS422	9600 baud max.
digital current loop	4800 baud max.

* Simultaneous installation with alarm outputs and power supply module is not possible. Neither of them is available for the HMP231.

Technical Information

Electronics housing

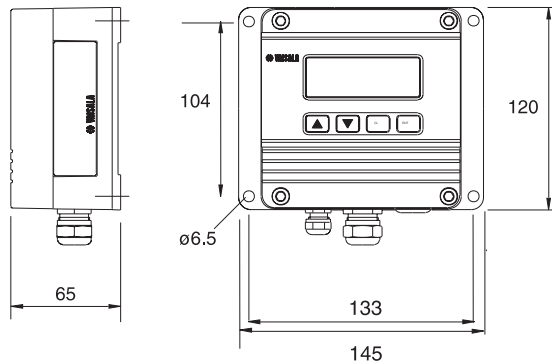

HMP231

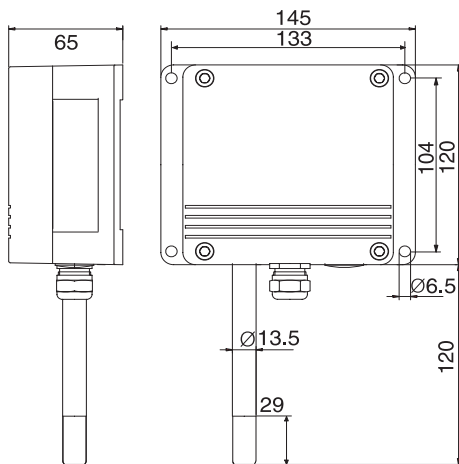

Installation flange of the HMP235

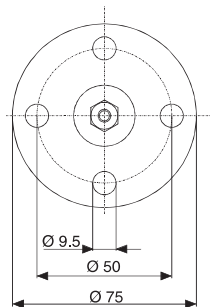

Dimensions in mm

Specifications subject to change without further notice.
HUMICAP® is a registered trademark of Vaisala
© Vaisala Oy



HMP233

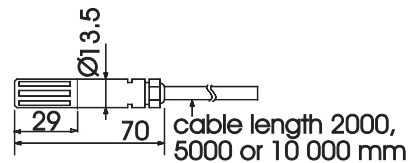

HMP234

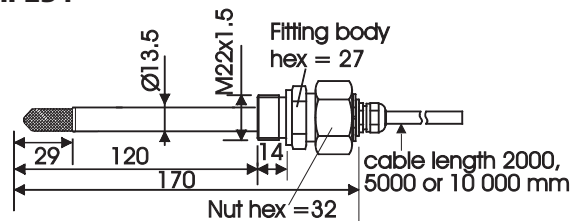

HMP235

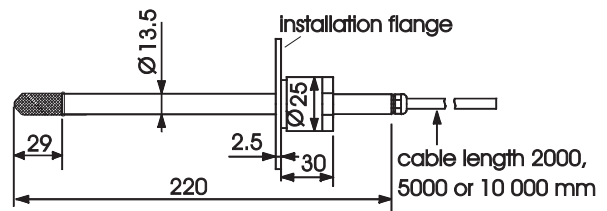

HMP238

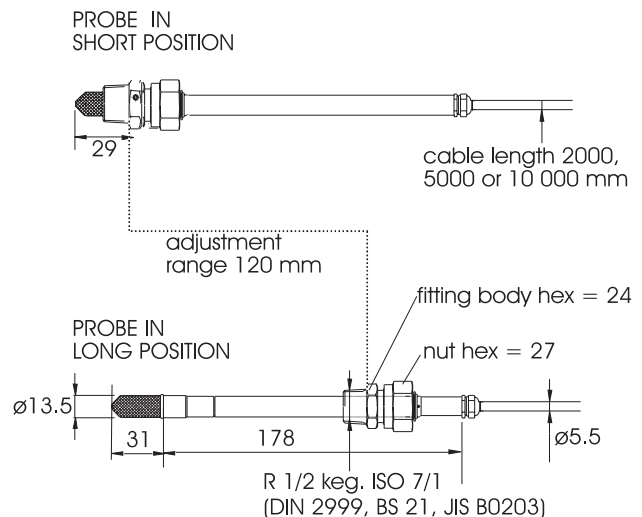

Head office:
Vaisala Oyj
P.O. Box 26
FIN-00421 Helsinki
FINLAND
Phone: (+358 9) 89 491
Telefax: (+358 9) 89 49 485
<http://www.vaisala.com>
industrialsales@vaisala.com

Vaisala Malmö
Drottninggatan 1 D
212 11 Malmö
SWEDEN
Phone nat.: 0200 848 848
Telefax: 0200 849 849

Vaisala GmbH
Postfach 540267
22502 Hamburg 54
GERMANY
Phone: (+49 40) 85 80 27
Telefax: (+49 40) 85 08 444

Vaisala (UK) Ltd
Suffolk House, Fordham Rd
Newmarket
Suffolk CB8 7AA
UNITED KINGDOM
Phone: (+44 1638) 67 44 00
Telefax: (+44 1638) 67 44 11

Vaisala Inc.
100 Commerce Way
Woburn, MA 01801-1068
USA
Phone: (+1 781) 93 34 500
Telefax: (+1 781) 93 38 029

Vaisala KK
42 Kagurazaka 6-chome
Shinjuku-ku
Tokyo 162
JAPAN
Phone: (+81 3) 32 66 96 11
Telefax: (+81 3) 32 66 96 10

Vaisala Pty Ltd
3 Guest Street
Hawthorn. VIC 3122
AUSTRALIA
Phone: (+61 3) 98 18 42 00
Telefax: (+61 3) 98 18 45 22
A.C.N. 006 500 616

Vaisala Beijing Representative Office
Room 520, Wangfujing Grand Hotel
No. 57, Wangfujing Street
Beijing 100006
PEOPLE'S REPUBLIC OF CHINA
Phone: (+86 10) 65 22 40 50
Telefax: (+86 10) 65 22 40 51