

# BABBITT INTERNATIONAL

## MAGNETIC LIQUID LEVEL GAGE

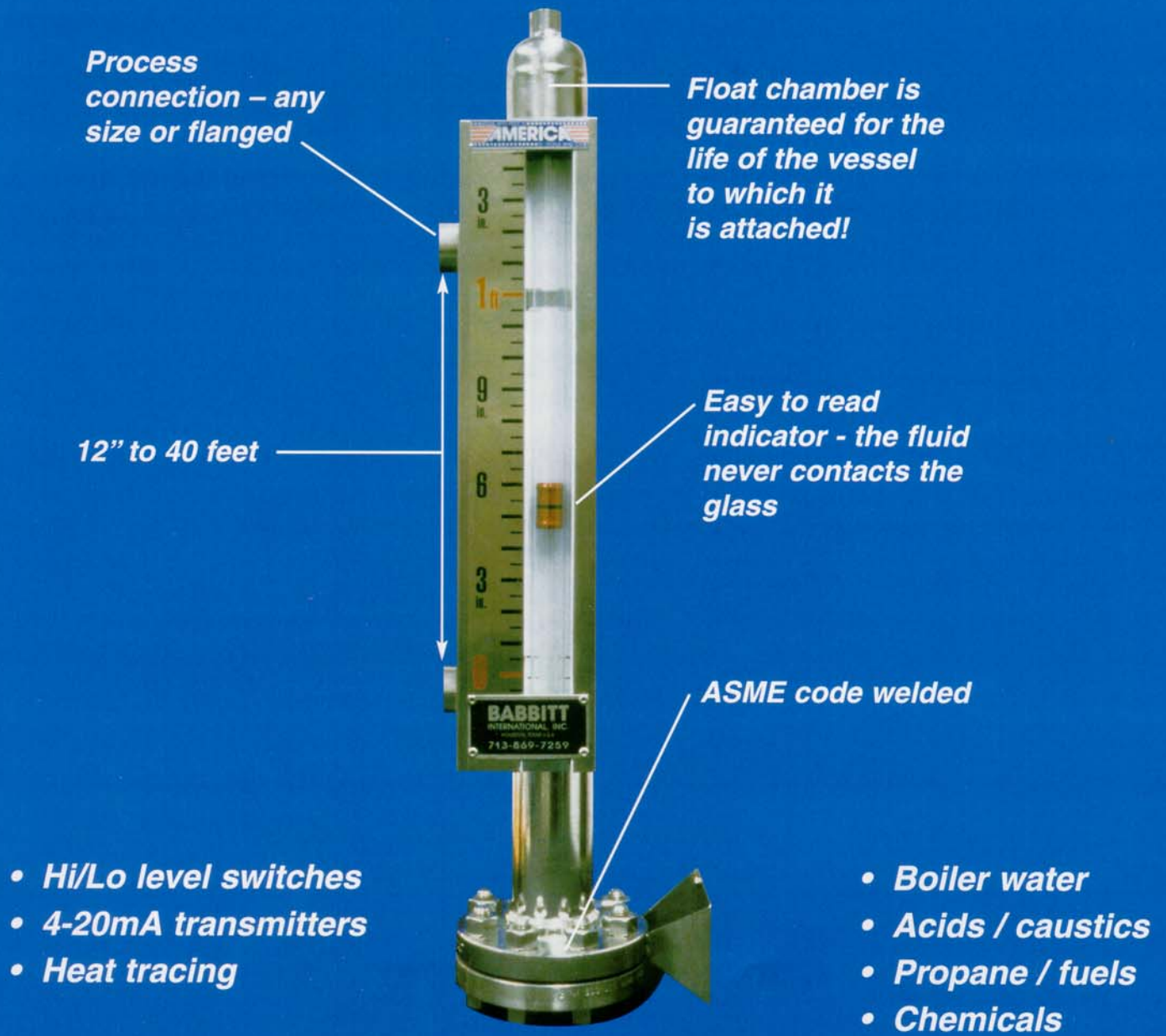

**SIMPLE • SAFE • RELIABLE**

# MODEL LG-Series Level Indicators

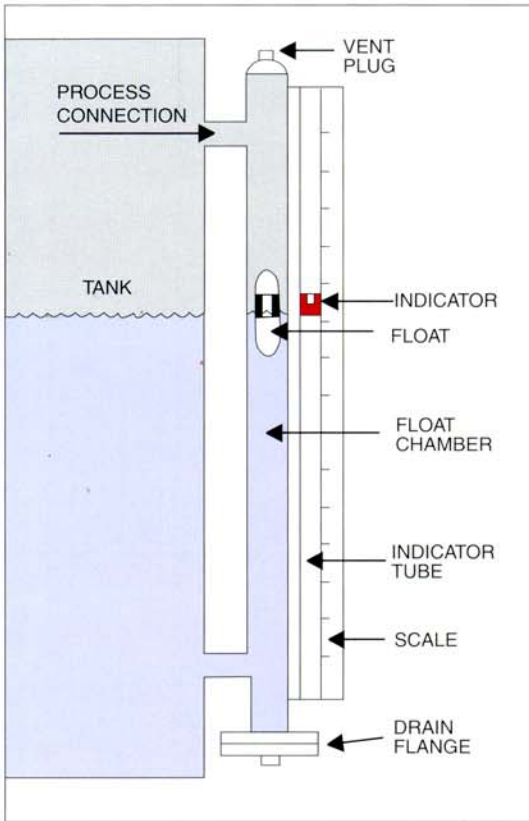

**Standard LG-Series Indicator**  
(Flipper style indicator also available;  
see page 4 for Indicator options)

## General

The basic Babbitt magnetic level gage offers simple visual level indication. By using the LT-1 transmitter, a 4-20mA signal can be sent to a remote location for indication or control functions. Additionally, level switches can be added, external to the float chamber, for alarm or control. These switches can easily be moved up or down the float chamber without shutting down or disturbing the process.

## Construction

The float chamber is typically a 2 1/2 inch stainless steel pipe with process connections that match those of the vessel. Some standard configurations are described in Table 1 on the facing page. All gages are custom made; any piping configuration is available.

The float construction is determined by the process fluid, pressure and temperature, and the specific gravity of the process fluid. Most processes use a stainless steel float, but other materials of construction are available, including exotic metals and plastics. In the sealed float is a 360° ring of magnets.

The standard indicator tube is made of glass, filled with an inert gas to eliminate condensation and hermetically sealed. An optional polycarbonate tube is available with a maximum temperature limit of 250°F. Inside the indicator tube is a lightweight magnetized indicator that is magnetically coupled to the float. This brightly colored indicator travels up and down tracking the fluid level. An operator can read the tank level from a distance of more than 100 feet.

## Safe, Simple, Reliable

Babbitt magnetic level gages are safe because the fluid never contacts the indicating glass. Should the glass ever break, there is no possibility of leakage. This is important if the liquid being measured is toxic, corrosive, flammable and/or in a high pressure or high temperature service.

Understanding the gages operation is simple. The fluid in the tank seeks its own level in the float chamber. The float in the chamber tracks the fluid level. Inside

the float assembly are magnets, located 360° around the floats inside circumference. These magnets move the visual indicator and actuate any switches or transmitters mounted on the gage.

The only moving part in the process is the float, giving this device a high degree of reliability. All maintenance to the indicator, level switches, or transmitter is external to the process.

## General Specifications

<b>Material:</b>	All wetted parts and external metal parts are stainless steel. Indicator tube is glass or polycarbonate. Other materials are available as options.
<b>Float Chamber:</b>	2 1/2 inch pipe with RF slip-on/Blind drain flange (standard) Pressure Rating: up to 4000 psig      Minimum Specific Gravity: 0.25 Temperature Rating: -200 to +1100 Deg. F Continuous
<b>Scale:</b>	Feet and inches standard with 1/2 inch scale divisions; resolution approximately 1/4 inch (Custom scales also available.)
<b>Indicator:</b>	7/8 inch diameter by 1 1/4 inch long, brightly colored red (flippers optional)
<b>Testing:</b>	All LG-Series gages are hydrostatic tested to the pressure rating specified.
<b>Welding:</b>	Boiler / piping codes ASME B31.1 / B31.3

# Standard LG-Series Mounting Styles

Gages can be fabricated to meet any mounting configuration.

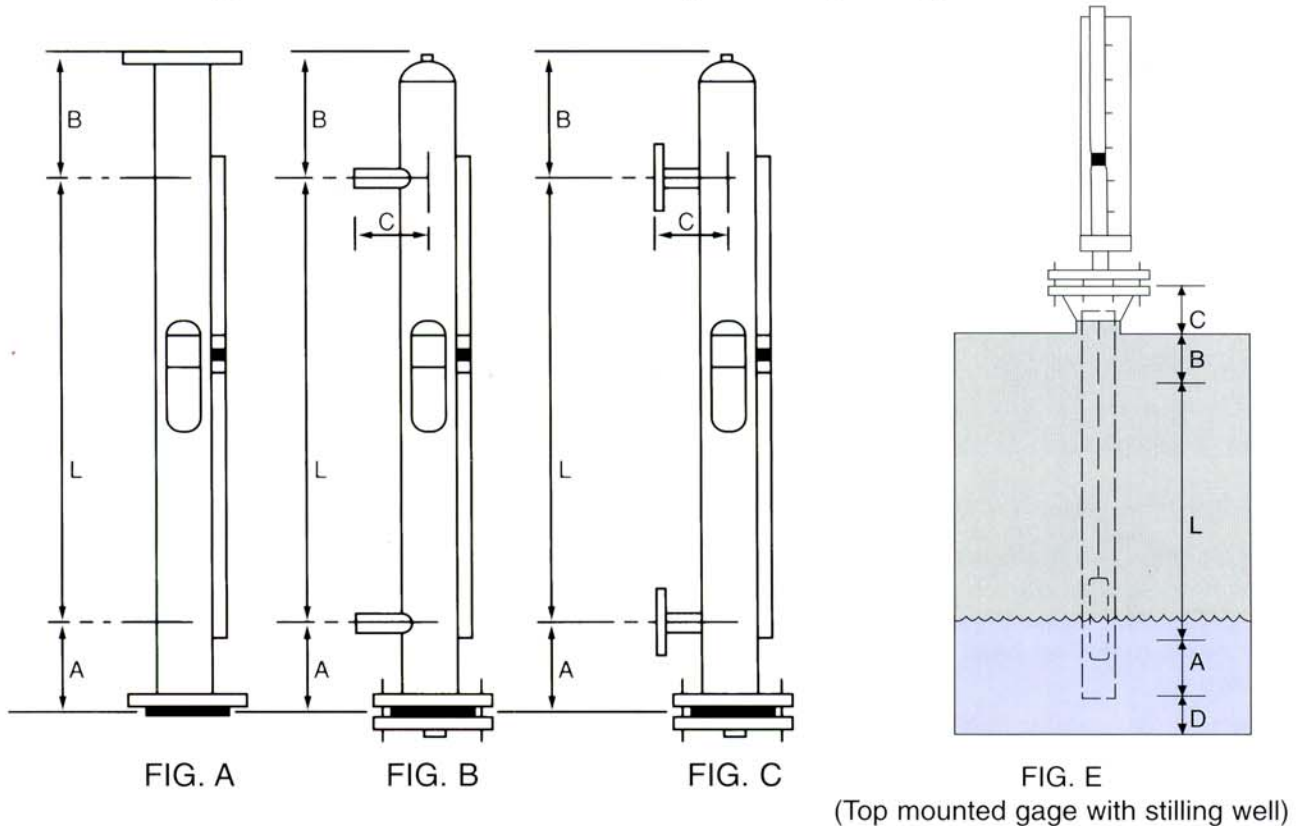

**NOTE:** Custom gages are available to accommodate other mounting configurations, Gages can be fabricated to meet most piping requirements.

Table 1

## Process Connections

- Fig. A: 2 1/2 in. RF Flanges
- Fig. B: 3000# threaded coupling; 1/2 in.; 3/4 in.; 1 in.; 1 1/2 in.; 2 in. FNPT
- Fig. C: 1/2 in. to 2 in. lap-joint flanges (other flange types optional)
- Fig. E: 3 in. Mounting Flange

**NOTE:** All flange bolt holes straddle center lines unless otherwise specified.  
1/2 in. NPT top vent and bottom drain plugs standard.

Table 2

## Indicator Dimensions (inches)

Dimension:	A**	B**	C**	D	L (measured length)
Fig. A:	8	6	—	—	Specify
Fig. B:	8	6	4	—	Specify*
Fig. C:	8	6	4	—	Specify*
Fig. E:	8	Specify	Specify	2 (min.)	Specify

\*Length to be measured center-to-center between process connections

\*\*Nominal Dimensions; may vary with low specific gravity fluids

Table 3

## Level Switches for Magnetic Level Gages

### GENERAL

Babbitt International offers level switches to meet your requirements for alarm and control functions. All of these switches are non-invasive; the float magnetically activates them directly through the chamber wall of the gage. Multiple control points can be added to the gage without cutting additional holes in the vessel.

The **MLS-3** is a hermetically sealed reed switch with form C contacts. A bias magnet latches the switch maintaining the output contact if the float continues to rise (or fall) past the point of actuation. The switch will unlatch only when the float passes the switch again in the opposite direction. This low cost switch is best suited for low power alarm signals.

The **MLS-3EX** is an explosion proof version of the MLS-3. It has terminal blocks for ease of wiring.

The **MLS-3EX-2** is a DPDT version (2 form C contacts).

The **MLS-10EX** is a high current level switch and an excellent choice for controlling pumps, alarms or solenoids. The switching mechanism is a cam activated internal UL approved switch. The unit can be factory set for rising or falling level applications. Meets Class I, Division 1 requirements.

The **PS-2** is a pneumatic switch designed to control air or natural gas from 15 to 100 PSI. The unit has a rotary cam activated non-bleed switch. When the float passes the switch, the cam rotates and latches the switch in the open position. This allows unrestricted airflow. When the float passes in the opposite direction, the switch unlatches and blocks the airflow. This non-bleed design is ideal for use with pneumatic alarms, valves and pumps. Factory configured for rising or falling fluid levels.

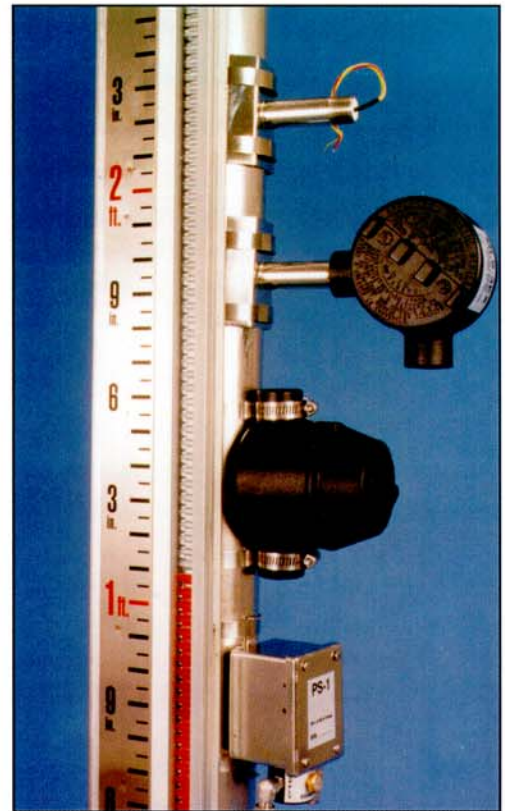

### Flipper/Roller Indicator Option

In addition to the standard magnetic follower style indicator, Babbitt also offers a flipper or roller type indicator. These consist of a series of small metal flags that are silver on one side and red on the other. As the magnetic float passes each flag with rising or falling liquid level, the flag rotates 180° to show the other color. Red indicates the liquid level and silver the vapor space. These flags are spaced every 0.4 inches (30 per foot) and give a very distinct red column corresponding to the tank level.

The flippers rotate on a ceramic and stainless steel bearing surface. They are housed in an extruded, anodized aluminum channel with a recessed glass window. After assembly, the unit is purged with inert gas (argon) and hermetically sealed. The assembly is custom made for each gage and is one continuous piece up to 20 feet, with no joints or blind spots.

These flippers have been tested through 50,000 cycles at float travel speeds from 10 feet per minute to 800 feet per minute without a failure. In violent or turbulent processes it is possible, though unlikely, that the standard magnetic follower can become temporarily decoupled. This cannot happen with the flippers. Flippers are rated for temperatures ranging from -200° to 850° F.

# MLS-3 SERIES

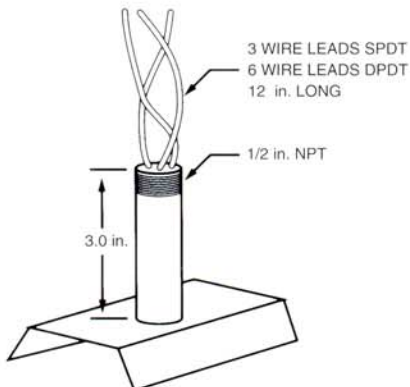

MLS-3

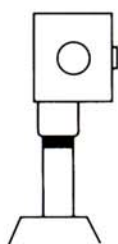

MLS-3EX

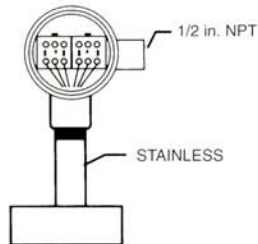

MLS-3EX/2

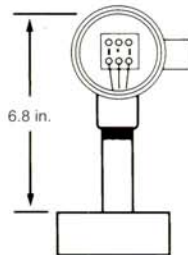

MLS-3EX

## SPECIFICATIONS

**Deadband** 0.5 inch  
**Maximum Temp.** 600 Deg. F  
**Minimum Temp.** -40 Deg. F  
**Contacts** SPDT or DPDT

**Contact Ratings**  
**Volts AC/DC** 150  
**Amps** 1.0  
**Watts** 50

**Housing** (MLS-3)  
304SS encapsulated  
(MLS-3EX)  
(Ex-Proof Condulet)

**Elec. Class** MLS-3: Gen Purpose  
MLS-3EX: Class 1  
Div. 1, Grps. B, C, & D  
UL & C-UL cUL Listed

## PS-2 SERIES

### SPECIFICATIONS

**Deadband** 0.5 inch  
**Maximum Temp.** 200 Deg. F  
**Minimum Temp.** 0 Deg. F  
**Supply Pressure** 30-100 psi  
(Dry, Filtered Air or Gas)  
**Housing** 316SS, NEMA 4

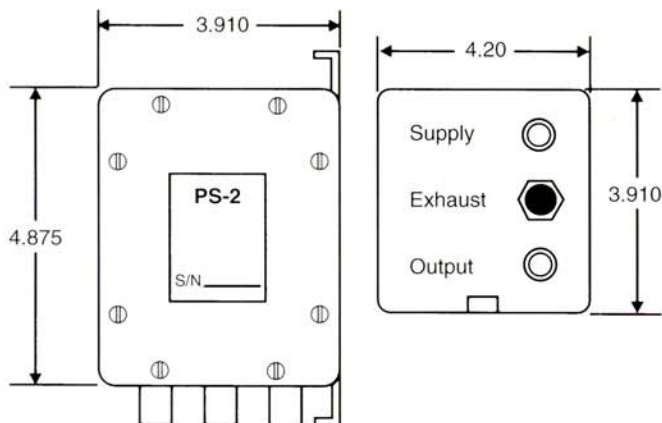

PS-2 PNEUMATIC SWITCH

## MLS-10EX SERIES

### SPECIFICATIONS

**Deadband** 0.5 inch  
**Maximum Temp.** 200 Deg. F  
**HT Version:** 450 Deg. F  
**Contacts** DPDT

**Contact Rating:**  
**10 AMP Max. @ 125/250 VAC**  
**1/2 AMP Max. @ 125 VDC**

**Housing** Ex-Proof Condulet  
Class 1, Div. 1, Grp. B, C, D.

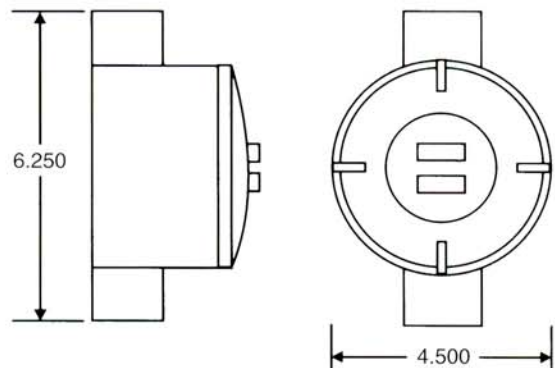

MLS-10EX

# LT-1 LEVEL TRANSMITTER

## Principle of Operation

The LT-1 Level Transmitter is designed for use with the LG Series Level Gage to provide a 4-20 mA control signal proportional to level. The transmitter mounts externally on the gage chamber and consists of a sensor tube made up of a string of resistors and magnetically operated reed switches. There is a switch and resistor every 1/2 inch along the length of the sensor tube (1/4 inch resolution option is available.)

The circuit board containing the resistors and switches may be the same length as the measured range or any portion thereof. The sensor circuit is encapsulated in the stainless steel sensor tube. A threaded connection at the top of the tube is for mounting the transmitter housing. This housing is rated for Class 1, Division 1, Groups B, C & D hazardous areas. The LT-1 assembly may be made intrinsically safe by remote mounting of the transmitter in a safe area and operating the sensor through an approved safety barrier.

As the magnetic float inside the gage chamber rises with increasing fluid level, the switches close, thereby changing the resistance in the circuit. A two-wire transmitter converts this resistance change to a 4-20 mA current signal corresponding to fluid level. Resolution of the transmitter is 1/2 inch or 1/4 inch which is proportional to the spacing of the sensor switches.

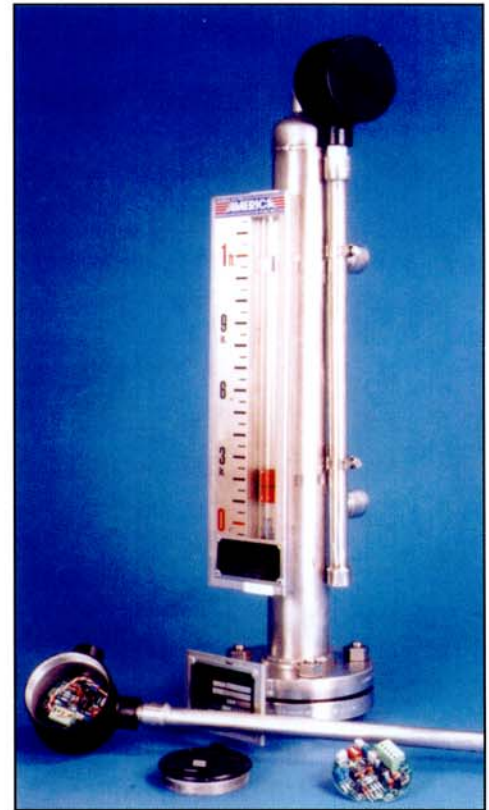

Non-Invasive LT-1 Transmitter

## Specifications

### Sensor:

- Length: up to 20 feet standard
- Resolution: 1/2 inch (1/4 inch optional)
- Housing: Stainless steel
- Operating Temp: to 500 Deg. F (process fluid)

### Transmitter:

- Output: 4-20 mA (2-wire)
- Load: 750 ohms max.
- Power: 24 VDC nominal
- Housing: explosion-proof, Class 1, Div. 1, Grps. B, C & D
- Temperature: 150 Deg. F. (inside housing)\*

Note: Complete assembly is UL & C-UL  listed for Class 1, Div. 1, Grps. B, C & D

\*Note: For higher temperature applications, transmitter should be mounted away from level chamber and sensing element. See manual for high temperature transmitter mounting.

## Part Number Example:

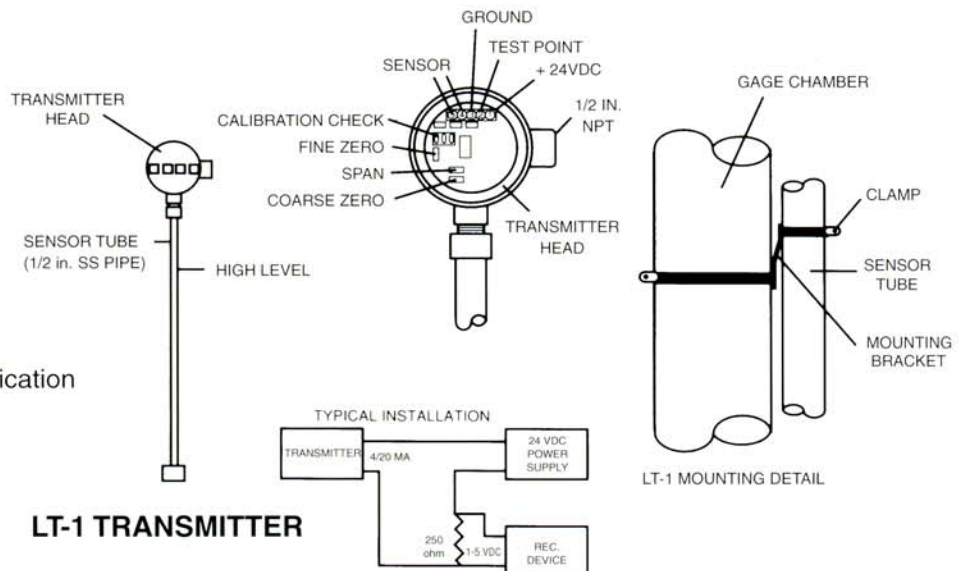
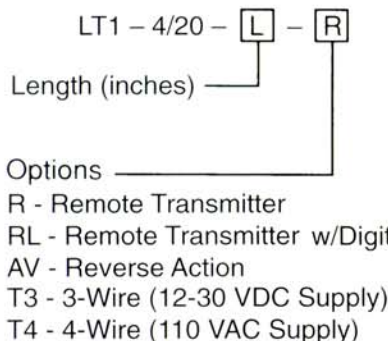

# QUOTATION REQUEST WORKSHEET FOR MAGNETIC LEVEL GAGES

Name \_\_\_\_\_ Date \_\_\_\_\_

Company \_\_\_\_\_

RETURN FOR QUOTE TO:

Address \_\_\_\_\_  
\_\_\_\_\_

Phone \_\_\_\_\_ FAX \_\_\_\_\_

Quantity \_\_\_\_\_ Chamber material (circle one) 316SS 304SS CPVC ALLOY-20 OTHER \_\_\_\_\_

Process fluid \_\_\_\_\_

Maximum operating pressure \_\_\_\_\_ PSIG Maximum operating temperature \_\_\_\_\_ Degrees F

Specific gravity of fluid \_\_\_\_\_ Chamber Style (see page 3) \_\_\_\_\_

Process connection size \_\_\_\_\_ inches Flange Rating \_\_\_\_\_ PSIG

Center to Center ( L dimension in inches ) \_\_\_\_\_ Indicator (circle one) INDICATOR TUBE FLIPPER/ROLLER

Level switches required? Quantity \_\_\_\_\_ Type \_\_\_\_\_

4-20 mA Loop Powered Transmitter? \_\_\_\_\_

Special requirements / Tagging \_\_\_\_\_  
\_\_\_\_\_

Part Number: \_\_\_\_\_

**All gages are custom made. If you have a special requirement, please use the space below for a sketch!**



**BEFORE:** A process vessel with three float switches, two short sight glasses, a pneumatic level controller and 15 valves and associated plumbing.



**AFTER:** The same vessel shown at left after installation of a magnetic gage and the same controls (plus more) at about half the cost to the customer.

### Order Information

Standard LG-Series Gages (316 SS) Example:

**\*Model LG6 B-- 3/4"--300#-- 0.92-- 100°F-- 250-- 36" --x**

Mounting Style  
A,B,C or E  
(see Table 1)

Process Conn. Sizes  
(see Table 2)

Flange Rating

Specific Gravity of  
Measured Fluid

Max. Operating Temp (°F)

Max Operating Press (psig)

Measurement Length "L" (in.)  
(see Table 3)

Options  
(for options not listed  
consult factory)

\*(LG6 = 316SS, LG4 = 304SS  
LGPVC = PVC etc.)

### Typical Options

- CS - Carbon Steel Flanges
- ST - Steam Trace
- HT - Heat Trace (electric)
- IB - Insulation Blanket
- FS - Flipper Indicator with Scale
- RJ - Ring Joint Flanges
- WN - Weld Neck Flanges
- 3A - 3A Approval for sanitary service
- FX - Fixed Flanges (RFSO)
- PI - Polycarbonate Indicator
- BV - Blocking Valve (specify type)
- VV - Vent Valve (specify type)
- DV - Drain Valve (specify type)
- X - Special Options (spell out description)

**Specifications subject to change without notice**