

## Resistive conductivity Transmitter



- Programmable outputs: two transistor and single or dual analog 4-20 mA
- Removable backlit display
- Universal fluidic process connection
- Three cell constants : to cover a wide measuring range
- Diagnostic function

Type 8222 can be combined with...



**Type 6642**  
Solenoid valve



**Type 2103**  
Diaphragm valve for continuous control



**Type 2030**  
On/Off Diaphragm valve

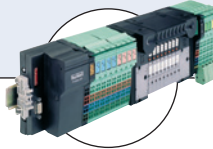

**Type 8644**  
Valve islands



**Type 8620**  
Cooling Tower or boiler chemistry controller

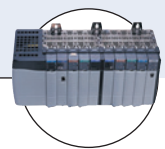

**PLC**

The Bürkert transmitter Type 8222 is a compact device, specially designed for measuring the conductivity value of fluids.

Our transmitter consists of a cell and a temperature sensor moulded in a sensor holder. This ensemble is plugged-in and cotted to an IP67 enclosure containing the electronic module with cover and a removable display. The conductivity sensor is available with three different cell constant C values, these with C = 0.01 or 0.1 are fitted with stainless steel electrodes and those with C = 1.0 are fitted with graphite electrodes

The conductivity transmitter can operate independent of the display, but it will be required for programming the transmitter (i.e. selection of sensor cell constant, language, measuring range, engineering units...) and also for visualizing continuously the measured and processed data.

The device Type 8222 is available:

- with three fully programmable outputs: two transistor and one 2-wire 4-20 mA current outputs
- with four fully programmable outputs: two transistor and two 3-wire 4-20 mA current outputs.

The device Type 8222 converts the measured signal, displays different values in different units (if display mounted) and computes the output signals, which are provided via one or two M12 fixed connectors.

### Technical data (Pipe + transmitter)

<b>Pipe diameter</b>	1/2" to 4" (DN 15 to 100)
<b>Conductivity measurement</b>	2 resistive conductivity electrodes
Measuring range	0.05 µS/cm... 10 mS/cm
Resolution	1 nS/cm
Accuracy	± 3% of measured value
<b>Temperature measurement</b>	
Measuring range	-40°F to 266°F (-40°C to +130°C)
Internal resolution	0.18°F (0.1°C)
Accuracy	± 1.8°F (1°C)
Minimal temperature range	50°F (10°C) (i.e 50°F to 68°F (10°C to 20°C) corresponding to 4-20 mA)
<b>Temperature compensation</b>	none or according to a predefined graph (NaCl or ultra pure water) or according to a graph defined especially for your process
<b>Medium temperature max. *</b>	Fitting or nut in: PVC: 122°F (50°C), - PP: 176°F (80°C) - PVDF: 212°F (100°C)
<b>Fluid pressure max</b>	232.16 PSI (PN16) (see pressure / temperature chart)

\* If the specific max. medium temperature for the used probe is lower than the max. temperature given in the above technical data chart, please take the lowest temperature as max.

### Environment

<b>Ambient temperature</b>	14°F to 140°F (-10°C to +60°C) (operating and storage)
<b>Relative humidity</b>	≤ 85%, without condensation

# 8222 ELEMENT Transmitter



Electrical data	
<b>Power supply</b>	
3 outputs transmitter (2-wire)	14-36 V DC, filtered and regulated
4 outputs transmitter (3-wire)	12-36 V DC, filtered and regulated
<b>Current consumption</b> with sensor	≤ 1 A (with the 2 transistors loads)
3 outputs transmitter (2-wire)	≤ 25 mA (at 14 V DC without transistors load, with current loop)
4 outputs transmitter (3-wire)	≤ 5 mA (at 12 V DC without transistors load, without current loop)
<b>Reversed polarity of DC</b>	Protected
<b>Voltage peak</b>	Protected
<b>Short circuit</b>	Protected for transistor outputs
<b>Output</b>	
Transistor	configurable as sourcing or sinking (respectively both as PNP or NPN), open collector max. 700 mA, 0.5 A max. per transistor if the 2 transistor outputs are wired output NPN: 0.2 - 36 VDC output PNP: V+ power supply
Current	4-20 mA programmable as sourcing or sinking,
3 outputs transmitter (2-wire)	max. loop impedance: 1100 Ω at 36 V DC; 610 Ω at 24 V DC; 180 Ω at 14 V DC
4 outputs transmitter (3-wire)	configurable in the same mode as transistor: sourcing or sinking, max. loop impedance: 1100 Ω at 36 V DC; 610 Ω at 24 V DC; 100 Ω at 12 V DC
Response time (10% - 90%)	150 ms (standard)

General data	
<b>Compatibility</b>	Any pipe from DN 10 to 110 in PVC or PVDF which are fitted out with Bürkert Fitting S022 (see corresponding data sheet)
<b>Materials</b>	See exploded view, opposite
Housing / cover	Stainless steel 1.4561, PPS / PC
Gaskets / Screws	EPDM / Stainless steel
Fixed connector mounting plate	Stainless steel
Fixed connector	Brass nickel plated
Display / navigation key	PC / PBT
Nut	PVC or PVDF
Wetted part materials	
Conductivity sensor	PVDF, stainless steel 1.4571 (316Ti)
Electrode	Stainless steel 1.4571 (316Ti) for cell constant C = 0.01 or C = 0.1 or graphite for cell constant C = 1.0
<b>Temperature sensor</b>	Pt1000 (316Ti) integrated within the sensor electrode holder
<b>Display (accessories)</b>	Grey dot matrix 128 x 64 with backlighting
<b>Electrical connections</b>	
3 outputs transmitter (2-wire)	1 x 5-pin M12 male fixed connector ,
4 outputs transmitter (3-wire)	1 x 5-pin M12 male and 1 x 5-pin M12 female fixed connectors
<b>Connection cable</b>	Shielded cable

Standards, directives and approvals	
<b>Protection class</b>	IP67 with M12 cable plug mounted and tightened and cover fully screwed down
<b>Standard and directives</b>	
EMC	EN 61000-6-2, EN 61000-6-3
Pressure	Complying with article 3 of §3 from 97/23/CE directive.*
Vibration / Shock	EN 60068-2-6 / EN 60068-2-27
<b>Approvals</b>	
UL recognized for US and Canada	61010-1 + CAN/CSA-C22 No.61010-1

## Pressure / temperature chart

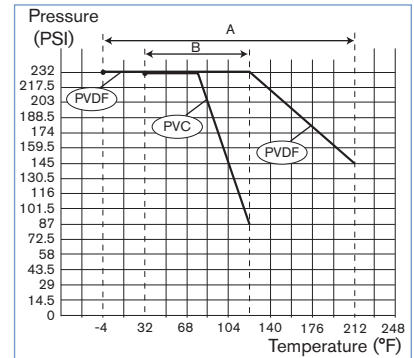

A: application range of a 8202 with a PVDF nut  
B: application range of a 8202 with a PVC nut

The measures have been made at an ambient temperature of 140°F (60°C), without probe.

## Materials view

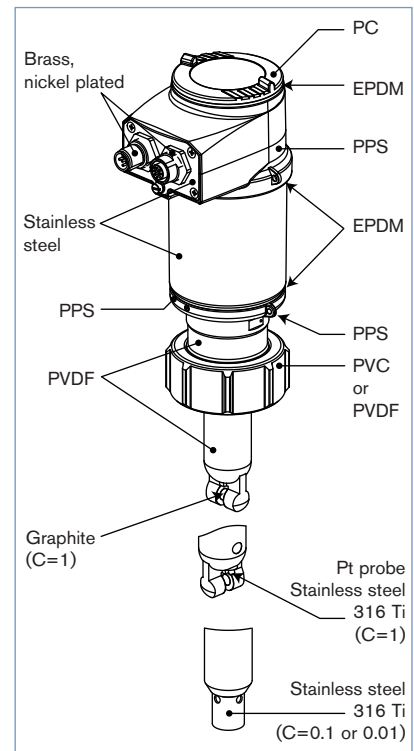

\* For the 97/23/CE pressure directive, the device can only be used under following conditions (depend on max. pressure, pipe diameter and fluid).

Type of fluid	Conditions
Fluid group 1, §1.3.a	DN ≤ 25 only
Fluid group 2, §1.3.a	DN ≤ 32, or DN > 32 and PN*DN ≤ 1000
Fluid group 1, §1.3.b	DN ≤ 25, or DN > 25 and PN*DN ≤ 2000
Fluid group 2, §1.3.b	DN ≤ 125

## Principle of operation

Conductivity is defined as the ability of a solution to conduct electrical current. The load carriers are ions (E.G. dissolved salt or acids). In order to measure conductivity, 2 electrodes are used which are set at a fixed distance apart and with a known specified surface. An AC voltage source is connected to the electrodes. The measured current is a direct function of the conductivity of the solution. The transmitter functions in a two wire circuit (single transmitter version) or three wire circuit (dual transmitter version) and requires a power supply of 14 V DC (single transmitter version) or 12 V DC (dual transmitter version) up to 36 V DC.

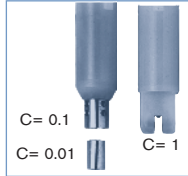

Different electrode designs are required based on selected cell constant.

The conductivity transmitter can be fitted with 3 different electrodes with cell constants 0.01; 0.1 and 1.0.

The electrode is selected according to the measuring range and medium by using the table below.

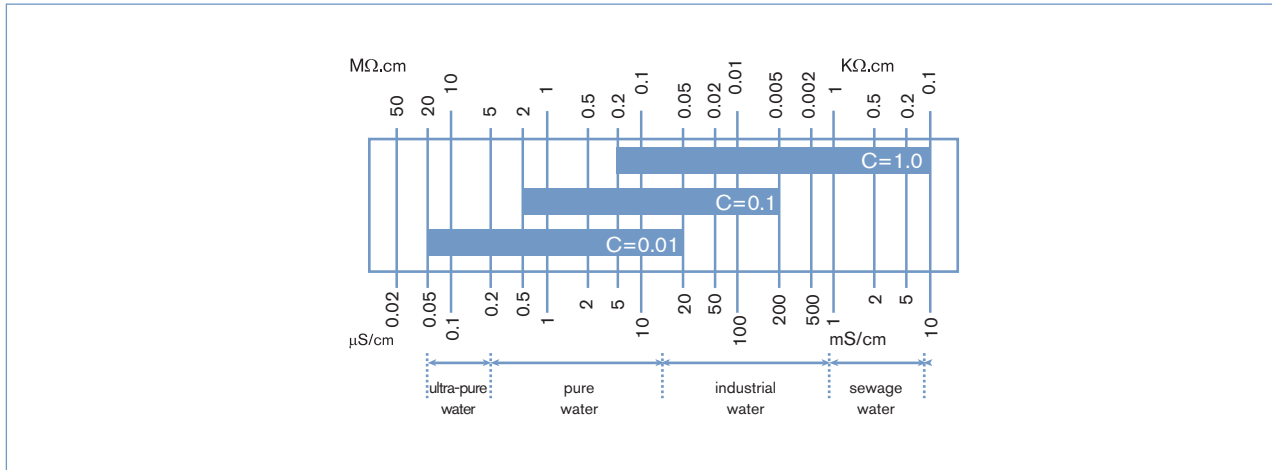

## In-line installation

The 8222 conductivity transmitter can be installed into any fitting system with G 1" ½ external threaded sensor connection by just fixing the main nut. Select and install the required fitting onto the pipe, according to specific requirements of the sensor and material (temperature and pressure). For a mounting on a tank or a direct mounting on a pipe (DN100 and 110), an adaptor with a G 1" ½ external threaded sensor connection must be used through the tank or pipe wall.

Install cautiously the transmitter on the fitting. The transmitter can be installed in any position (**prefer "A" mounting to install a 8222 with sensor C=0.1 or C=0.01**). In order to get reliable measurement, air bubbles must be avoided, and the mounting location must ensure that the electrode is continuously and completely immersed in the flow stream.

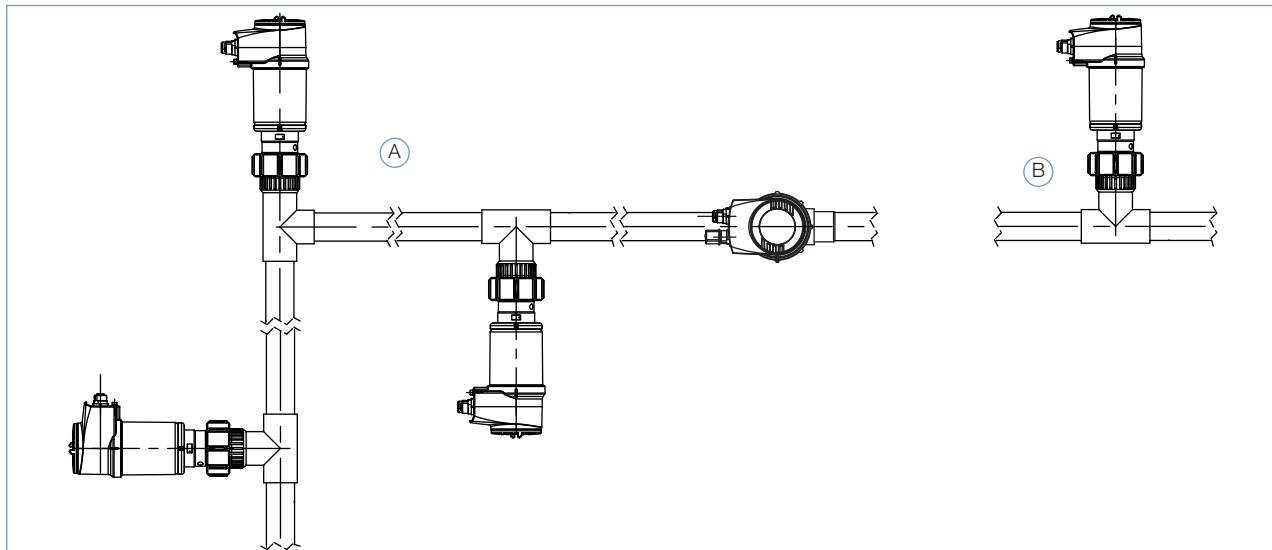

The transmitter must be protected from constant heat radiation and other environmental influences, such as direct exposure to sunlight.

Dimensions [mm] of transmitter Type 8222

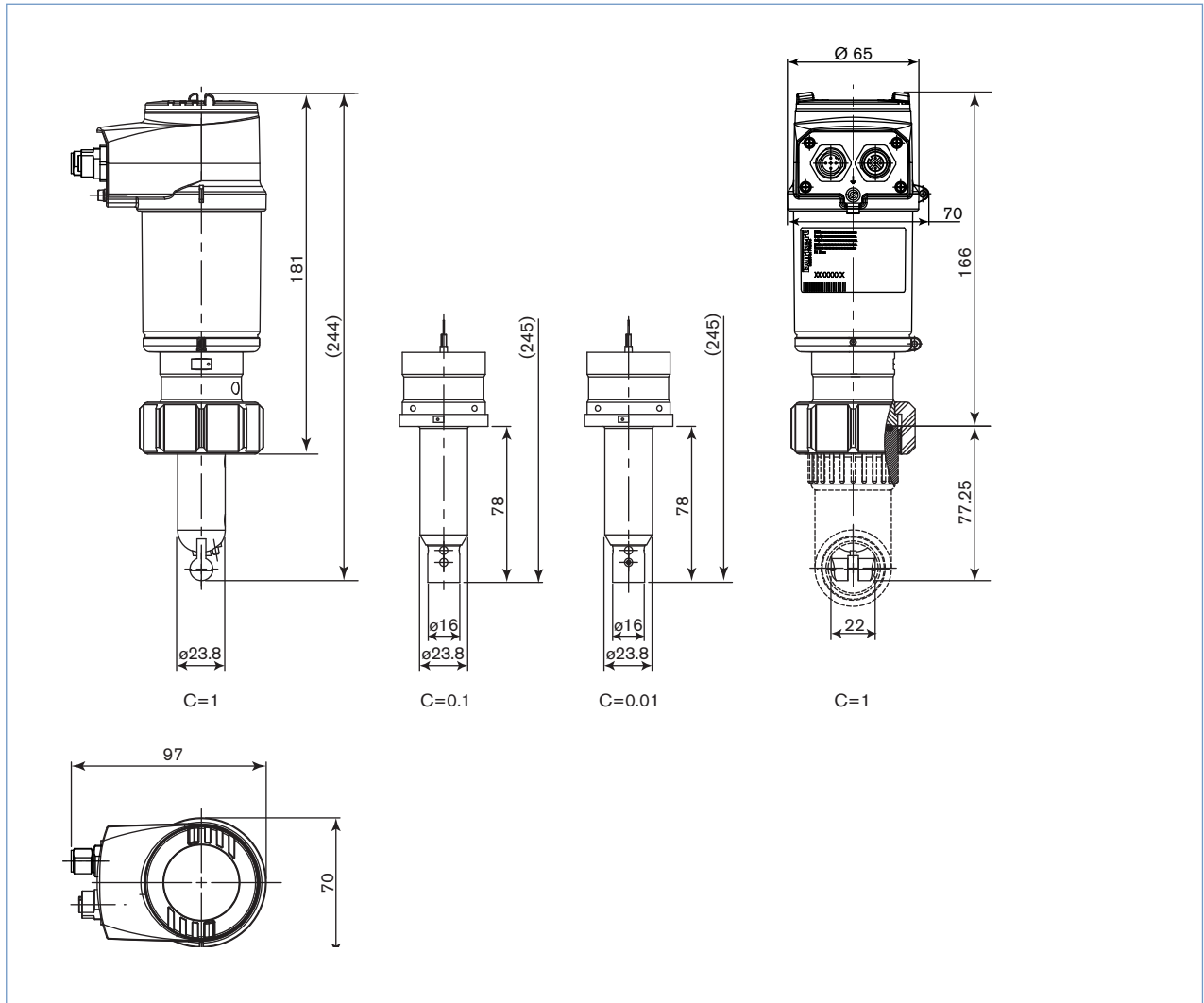

## Ordering chart for compact transmitter Type 8222

### A complete compact conductivity transmitter Type 8222 consists of

- a compact conductivity transmitter Type 8222
- a removable display/programmer (see accessories)
- a fitting with G 1" 1/2 external threaded sensor connection (see data sheet Type S022)





### Conductivity transmitter Type 8222

Specifications	Voltage supply	Output	Sensor version	Nut material	Electrical connection	Item no.
Compact transmitter without display	14-36 V DC	2 x transistors + single 4-20 mA for process conductivity only	C = 0.01	PVC	5-pin M12 male fixed connector	559 618
				PVDF	5-pin M12 male fixed connector	559 620
			C = 0.1	PVC	5-pin M12 male fixed connector	559 614
				PVDF	5-pin M12 male fixed connector	559 616
			C = 1.0	PVC	5-pin M12 male fixed connector	559 610
				PVDF	5-pin M12 male fixed connector	559 612
	12-36 V DC	2 x transistors + dual 4-20 mA for both temperature and conductivity	C = 0.01	PVC	5-pin M12 male and 5-pin M12 female fixed connectors	559 619
				PVDF	5-pin M12 male and 5-pin M12 female fixed connectors	559 621
			C = 0.1	PVC	5-pin M12 male and 5-pin M12 female fixed connectors	559 615
				PVDF	5-pin M12 male and 5-pin M12 female fixed connectors	559 617
			C = 1.0	PVC	5-pin M12 male and 5-pin M12 female fixed connectors	559 611
				PVDF	5-pin M12 male and 5-pin M12 female fixed connectors	559 613

**Note: Order separately** (see accessories)

- display/programmer module
- M12 cable plugs (only female for single 4-20 mA, 1 male + 1 female for dual 4-20 mA transmitter)

**Ordering chart for accessories**

Description		Item no.
Removable display/programmer module (with instruction sheet)		559 168
Black blank cover with seal		560 948
Buffer solution, 500 ml, 5 µS		440 015
Buffer solution, 500 ml, 15 µS		440 016
Buffer solution, 500 ml, 100 µS		440 017
Buffer solution, 500 ml, 706 µS		440 018
Buffer solution, 500 ml, 1413 µS		440 019
	5 pin M12 female straight cable plug with plastic threaded locking ring, to be wired	98123241
	5 pin M12 male straight cable plug with plastic threaded locking ring, to be wired	98123242
	5 pin M12 female straight cable plug moulded on cable (2 m, shielded)	98123596
	5 pin M12 male straight cable plug moulded on cable (2 m, shielded)	98123931

**Interconnection possibilities with other Bürkert devices**

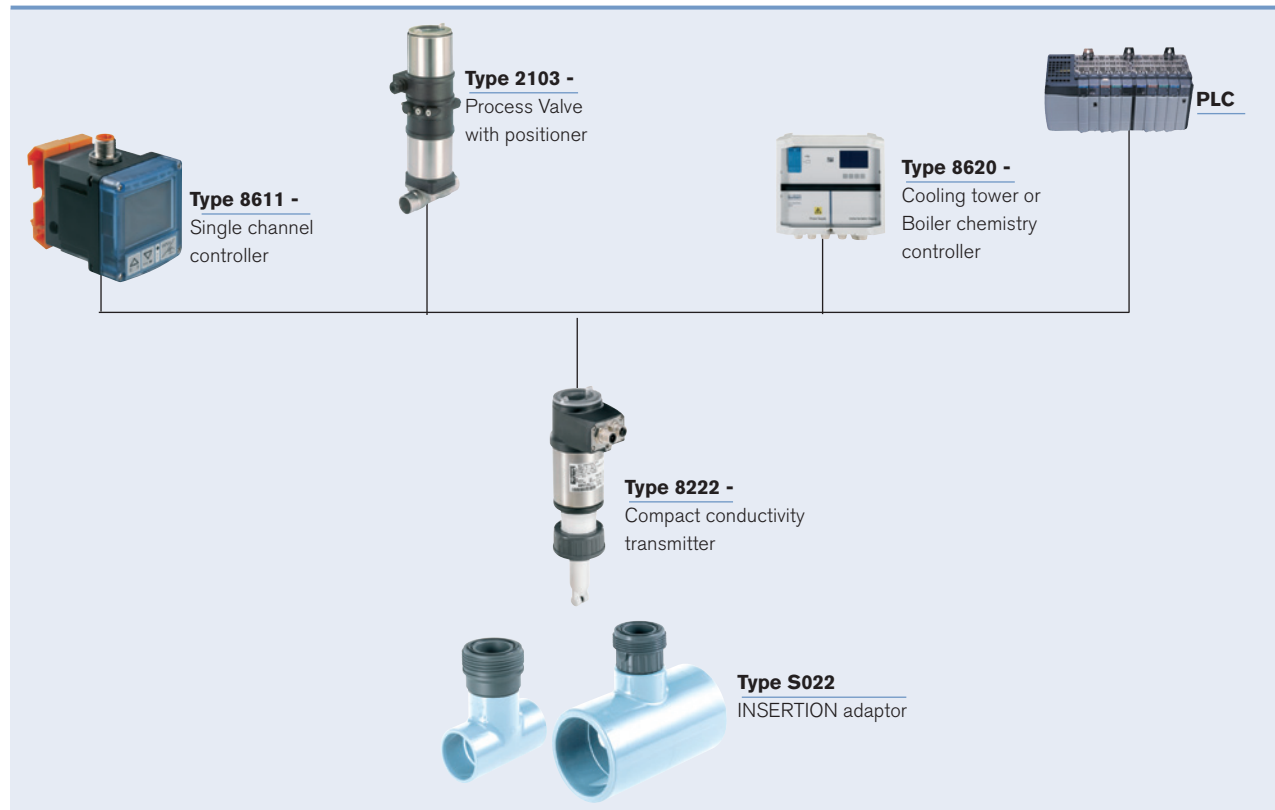

DTS 1000127757 EN Version: - Status: RL (released | freigegeben | validé) printed: 02.02.2010