

DN 15 - DN 50; PN 16



### Advantages / Benefits

- ▶ Easy System integration by Easy LINK provides low cost of ownership
- ▶ Can be upgraded to a low cost transmitter providing calibrated pulse output or 4...20 mA
- ▶ Easy mounting and demounting of sensor head by a quarterturn
- ▶ 3-wire Hall version to interface directly with PLC's (both NPN and PNP)
- ▶ Easy to connect:  
Directly powered from the 8025 panel or 8025 wall
- ▶ Fittings available for all standard hydraulic interfaces

### Design

The paddle-wheel flow sensor for continuous flow measurement is specially designed for use in neutral, solid-free liquids.

The sensor is made of a compact fitting and an electronic-module quickly and easily connected together by a bayonet. The Burkert designed brass-fitting system (all international threaded port connections) ensures simple installation of the sensors into all pipes from DN 15 to DN 50.

The sensor produces a frequency signal proportional to the flow which can easily be transmitted and processed.

- 4...20 mA output signal with transmitter module
- Adjustable frequency output signal with pulse divider module
- Direct connection to batch controller type 8600 mounted on valve
- Connection to separate versions of flow transmitter/indicator type 8025/SE34:
  - Panel version
  - Wall-mount version

### Applications

#### Flow Measurement & Dosing Control

Industrial water

Cooling water monitoring

Auxiliary plants

Irrigation

Ideal for industrial cold and hot water applications

**burkert**  
Easy Fluid Control Systems

# Flow Sensor

for continuous flow measurement

**Type 8030**  
**Brass-INLINE**

## Design

The flow sensor consists of a transducer (coil or Hall sensor) and an open-cell paddle wheel directly connected to a compact fitting.

In a 2 or 3-wire system, the signal can be displayed or processed directly. The output signal is provided via a 4-pole cable plug according to DIN 43650.

## Principle of operation

When liquid flows through the pipe, the paddle-wheel is set in rotation producing a measuring signal in the transducer. The induced voltage is AC. The frequency and amplitude are proportional to the flow.

The flow sensor 8030 with Hall sensor requires an external power of 12...30 VDC.

The flow sensor 8030 with coil requires no external power supply.

The flow sensor 8030 with 4...20 mA output requires an external power of 12...24 VDC.

The flow sensor 8030 with adjustable frequency output requires an external power of 12...30 VDC.

The sensor measures a flow rate from 0.3 m/s (1 ft/s).

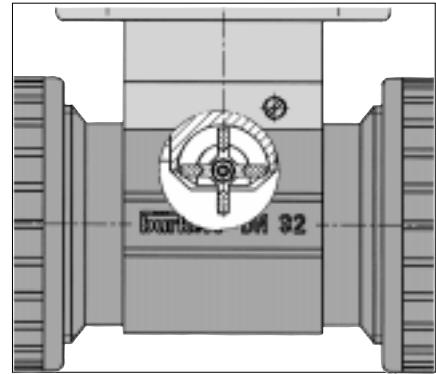

## Installation

The flow sensor is made of a compact fitting and an electronic module which can be quickly and easily connected by means of a Quarter Turn.

The recommended In- and Outflow straight pipe length should respect 10xD in and 3xD out.

According to pipe's design, necessary distances can be bigger or use a flow conditioner to obtain the best accuracy. For more informations, please refer to EN ISO 5167-1.

The flow sensor can be installed in either horizontal or vertical pipes.

The suitable pipe size is selected using the diagram on the next page. Pressure and temperature ratings must be respected according to the selected fitting material (see next page).

The flow sensor is not designed for gas flow measurement.

*Easy* to install

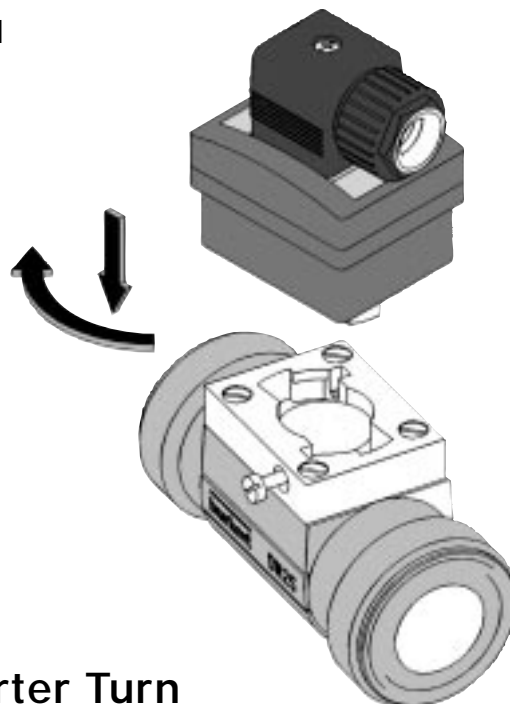

**Burkert Quarter Turn**

**Examples of fitting selection**

The suitable pipe size is selected using the diagram below.

**Example 1 :**  
Specification of nominal flow: 10 m<sup>3</sup>/h  
Ideal flow velocity: 2...3 m/s  
For these specifications, the diagram indicates a pipe size of DN 40.

**Example 2 :**  
Specification of nominal flow: 50 gpm  
Ideal flow velocity: 8 fps  
For these specifications, the diagram indicates a pipe size of 1 1/2".

**Diagram Flow-Pipe Size-Velocity**

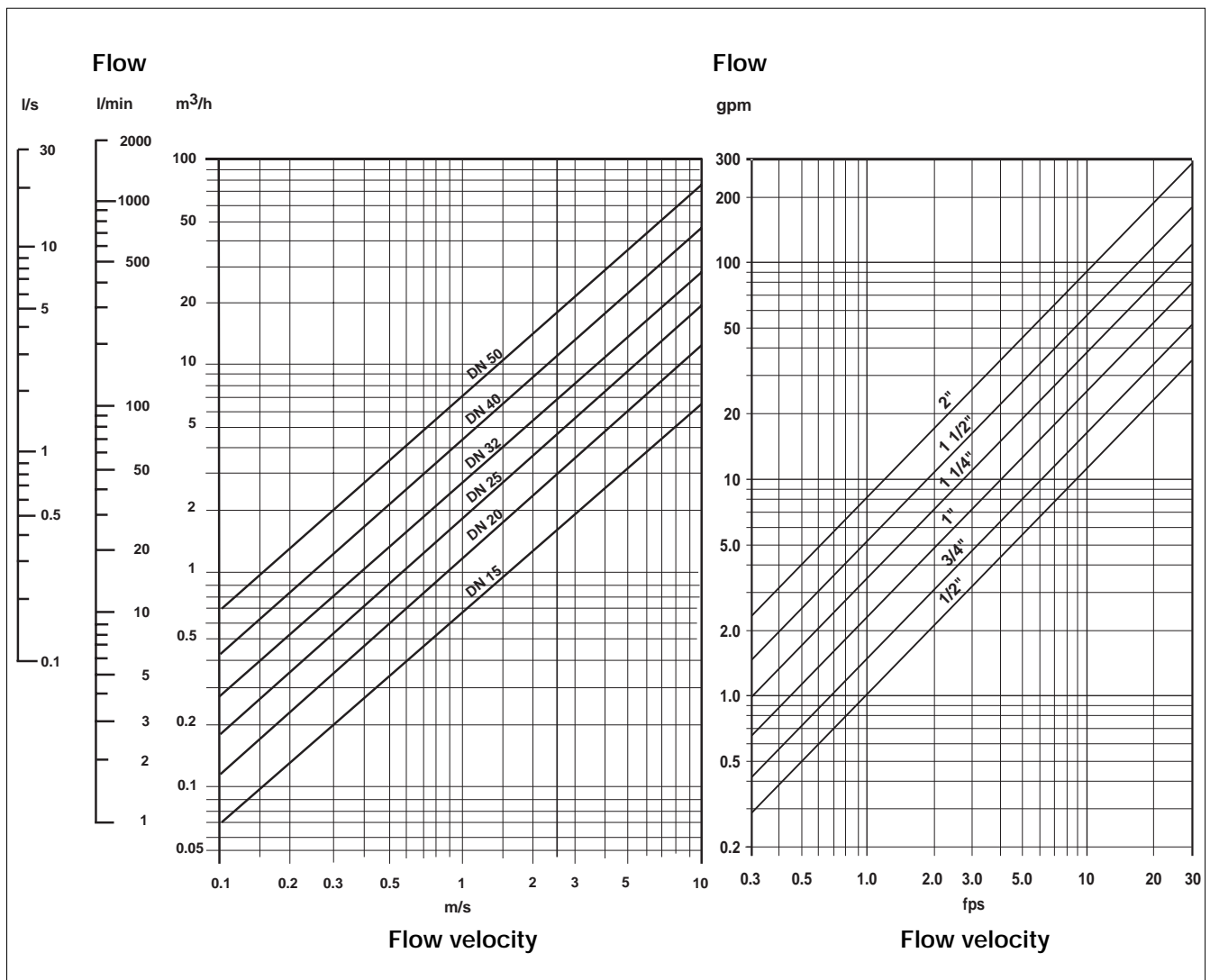

Connection to other Burkert devices

8030 with Hall sensor



Batch Controller 8600



Calibrated frequency output module 8021



8030 with Hall sensor  
"low power"



8025 / SE34 panel or wall-mount version

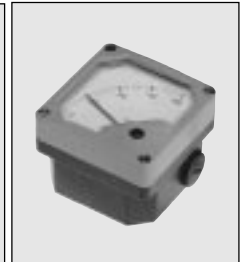

Calibrated frequency output module 8021



4...20 mA output module type 8023



8030 with coil



8025 / SE34 wall-mount with battery power supply



8025



SE34

# Flow Sensor

for continuous flow measurement

**Type 8030**  
**Brass-INLINE**

## Technical data

### General data

Pipe diameter from DN 15 to DN 50 (1/2" to 2")  
 Measuring range 0.3 m/s to 10 m/s (1.0 fps to 33 fps)  
 as from 3 l/min (DN15 pipe, 0,3 m/s flow velocity)  
 as from 0.9 gpm (1/2" pipe, 1.0 fps flow velocity)

Measuring error

- With individual works calibration (on request):  
 $\leq \pm 0.5\%$  o.F.S. (at 10 m/s) \*
- With standard mean K-factor:  
 $\leq \pm (0.5\%$  o.F.S. + 2.5% o.R.) \*

Linearity  $\leq \pm 0.5\%$  o.F.S. (at 10 m/s) \*  
 Repeatability 0.4% o.R. \*

Fluid temperature max. 0°C to 100°C (32 to 212°F)  
 Ambient temperature 0°C to 60°C (32 to 140°F)  
 Storage temperature 0°C to 60°C (32 to 140°F)  
 Pressure class PN 16  
 Enclosure IP 65

Fitting Brass  
 Sensor holder Brass  
 Paddle-wheel PVDF  
 Axis and bearing Ceramic  
 O-rings FPM standard  
 Housing PC  
 Tront plate foil Polyester

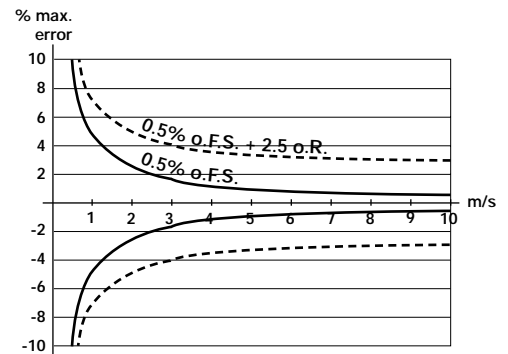

### Specific data 8030 with Coil

Cable length 10 m (use shielded cable of max. 1.5 mm<sup>2</sup> wire cross section)  
 (Can only be connected to flow transmitter type 8025/ indicator SE34 with battery power supply in wall-mount version)

### Specific data 8030 with Hall Sensor

Supply voltage 12...30 VDC  
 Output signal transistor PNP and NPN open collector max. 100 mA  
 frequency: 0...200 Hz  
 Cable length 50 m (use shielded cable of max. 1.5 mm<sup>2</sup> wire cross section)

### Specific data 8030 with Hall Sensor "low power"

(Can only be connected to separate versions of flow transmitter type 8025/ indicator SE34 and to 4...20 mA or calibrated frequency output modules)

### Specific data 8030 with 4...20 mA Output (8023)

Associated flow sensor Hall sensor "low power"  
 Supply voltage 12...24 VDC  
 Output signal 4...20 mA  
 Load max. 500Ω at 12 V  
 max. 1000Ω at 24 V  
 Accuracy  $\leq 2\%$   
 Material of additional housing PA

### Specific data 8030 with Calibrated Frequency Output (8021)

Associated flow sensor Hall sensors  
 Supply voltage 12...30 VDC  
 Output signal transistor PNP and NPN open collector max. 100 mA  
 Accuracy 0,1%  
 Material of additional housing PA

\* Under reference conditions, i.e. measuring fluid = water, ambient and water temperature = 20 °C, applying the minimum inlet and outlet pipe straights, matched inside pipe dimensions  
 o.R. = of reading  
 o.F.S. = of full scale (10 m/s)

Operation and display

Type 8023, 4...20 mA output module

The operation is specified according to two levels:

- ▶ **Indication in operating mode**
  - Flow (digits and bargraph)
- ▶ **Parameter definition**
  - K-factor
  - Time unit
  - 4...20 mA measuring range

The device works without the control unit. The control unit enables only to perform parameter definition.

4 ... 20 mA module with control unit (1077)



Type 8021 calibrated frequency output module

The operation is specified according to the following level:

- ▶ **Parameter definition**
  - K-factor
  - Multiplier D

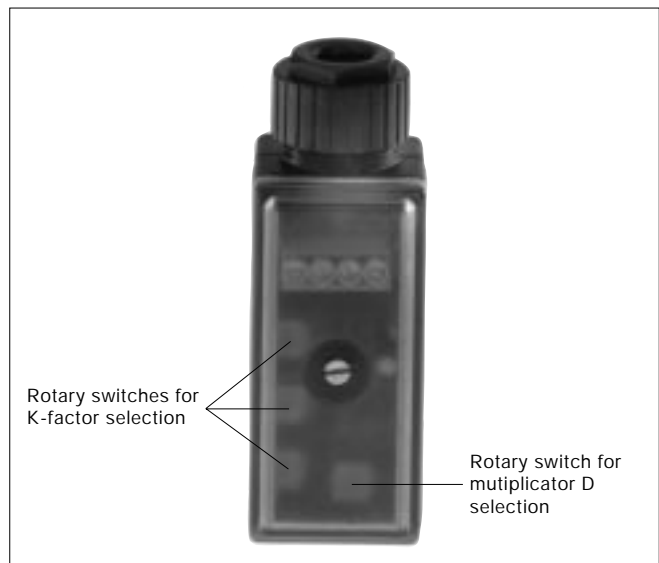

Dimensions [mm (inch)]

Internal threaded port connection

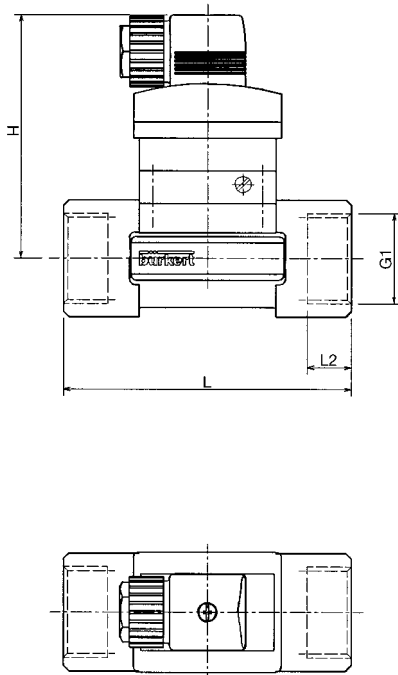

Dimensions G-Port connection

Port connection (Dimension G1)	DN	Variable dimensions [mm ]		
		L	L2	H
G 1/2	15	85	16.0	92
G 3/4	20	95	17.0	89
G 1	25	105	23.5	89.5
G 1 1/4	32	120	23.5	93
G 1 1/2	40	130	23.5	97
G 2	50	150	27.5	104

Dimensions Rc-Port connection

Port connection (Dimension G1)	DN	Variable dimensions [mm ]		
		L	L2	H
Rc 1/2	15	85	15.0	92
Rc 3/4	20	95	16.3	89
Rc 1	25	105	18.0	89.5
Rc 1 1/4	32	120	21.0	93
Rc 1 1/2	40	130	19.0	97
Rc 2	50	150	24.0	104

Dimensions NPT-Port

Port connection (Dimension G1)	DN	Variable dimensions [inch ]		
		L	L2	H
NPT 9/16	15	3.35	0.67	3.62
NPT 3/4	20	3.74	0.72	3.51
NPT 1	25	4.14	0.71	3.52
NPT 1 1/4	32	4.73	0.83	3.66
NPT 1 1/2	40	5.12	0.79	3.82
NPT 2	50	5.91	0.95	4.10

External threaded port connection

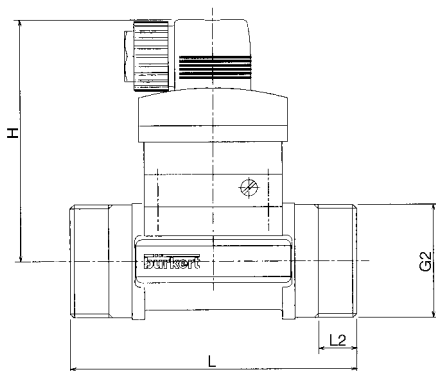

Dimensions [mm]

Port connection (Dimension G2)	DN	Variable dimensions [mm ]		
		L	L2	H
G 3/4	15	84	11,5	92
G 1	20	94	13,5	89
G 1 1/4	25	104	14	89.5
G 1 1/2	32	119	18	93
M 55x2	40	129	19	97
M 64x2	50	149	20	104

Dimensions [inch]

Port connection (Dimension G2)	DN	Variable dimensions [inch]		
		L	L2	H
G 3/4	15	3.31	0.45	3.62
G 1	20	3.70	0.53	3.51
G 1 1/4	25	4.09	0.55	3.52
G 1 1/2	32	4.69	0.71	3.66
M 55x2	40	5.08	0.75	3.82
M 64x2	50	5.87	0.78	4.10

# Flow Sensor

for continuous flow measurement

**Type 8030**  
**Brass-INLINE**

## Ordering Chart

A complete Flow Sensor System type 8030 is consisting of two or three basic units as to know.

- Fitting type S030 which houses the paddle-wheel,
- Sensor Electronic type SE30,
- Upgradable to a low-cost transmitter with calibrated pulse output or 4...20 mA output

This Flow Sensor can also be connected to a transmitter type 8025 in panel- or wall-mount version (see data sheet of type 8025 flow transmitter).

**Selection example:** A Flow Sensor System with 4...20 mA output for steel pipe DN25 consists of:

- Fitting type S030 (G-port connection internal thread) 423 982 B
- Sensor Electronic type SE30 (Hall sensor "low power") 423 914 E
- 4...20 mA output module type 8023 130 428 V
- Control unit for 4...20 mA output module type 1077-3 130 446 X

## Ordering Chart Fittings Type S030

### Brass body

Specifications	ITEM - NO.					
	DN 15	DN 20	DN 25	DN 32	DN40	DN 50
G-port connection (internal thread)	423 980 M	423 981 A	423 982 B	423 983 C	423 984 D	423 985 E
JIS (ISO 7)-port connection (internal thread)	423 992 D	423 993 E	423 994 F	423 995 G	423 996 H	423 997 A
NPT-port connection (internal thread)	423 986 F	423 987 G	423 988 R	423 989 J	423 990 P	423 991 C
G-port connection (external thread)	423 998 K	423 999 L	424 000 T	424 001 Q	424 002 R <sup>1)</sup>	424 003 J <sup>1)</sup>

<sup>1)</sup>Metric thread

## Ordering Chart Sensor Electronics Type SE30

Specifications	Power Supply	Cable Entry	ITEM - NO.
Coil Sensor (Only connectable to type 8025 wall-mount version with batteries)	None	DIN 43650 PG9	423 912 C
Hall Sensor	12-30 VDC	DIN 43650 PG9	423 913 D
Hall Sensor "low power" (only connectable to types 8025, 8021, 8023 and SE34)	from 8025/8023	DIN 43650 PG9	423 914 E

## Ordering Chart for Standard Output Signals

Specifications	Power Supply	Cable Entry	ITEM - NO.
Calibrated pulse output module type 8021	12-30 VDC	1x PG9	418 895 P
4...20 mA output module type 8023	12-24 VDC	1x PG9	130 428 V
Control unit for 4...20 mA output module type 1077-3	12-24 VDC	None	130 446 X



*Easy* Continuous Solenoid Control

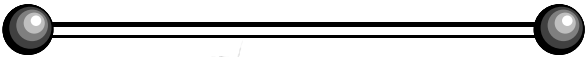

**1** up to **-75 %**



In case of special application requirements, please consult for advice.

We reserve the right to make technical changes without notice.  
802-GB/ 2-0004