

1/2" to 16"; Pressure to 87 PSI



Design

The Type 8045 Magmeter is an insertion type flow meter for pipe sizes from 1/2" – 16" (DN 15 – DN 400) and is ideally suited for dirty liquids or slurries, having a conductivity >20 μ S. Fittings are available in stainless steel, brass, PVC, PP and PVDF. A wide selection of end connections is offered including; NPT, flanged or Tri-Clamp®.

Featuring a proven technology, the Type 8045 is available in the same sizes and offers the same output signals as all of the Burkert inline rotor sensors. This includes: 4-20mA, a pulse and two relay outputs. The electronics are menu-guided and provide easy man-machine communication. A clear, easy-to-use text including engineering units are displayed on a large 8-digit LCD display. If required, any existing installation using Burkert insertion inline rotor

transmitters or sensors can be directly upgraded with the Type 8045 in a few minutes.

For easy start-up, a SIMULATION-MODE is available allowing the simulation of all output signals just as if actual flow existed. With this, the user can first simulate all flow conditions safely, including the alarm points, before putting the system into service. Calibration is done by either using the standard calibration factors or Burkert's unique TEACH-IN function. If TEACH-IN is used, the unit will do an auto-calibration once installed in the system.

The Type 8045 is a perfect choice for systems using Burkert Type 2030 and 2031 general purpose diaphragm valves for the control of liquids with or without suspended solid particles. Connection is done using the Burkert Easy LINK™ Sconcept.

Burkert Contromatic USA
2602 McGaw Avenue
Irvine, CA 92614
Tel. 949.223.3100
Fax 949.223.3198
www.burkert-usa.com

Burkert Contromatic Inc.
760 Pacific Road, Unit 3
Oakville, Ontario, Canada L6L 6M5
Tel. 905.847.5566
Fax 905.847.9006
www.burkert.ca

Advantages / Benefits

- ▶ **Easy System integration by Easy LINK** provides low cost of ownership
- ▶ **Solid-State sensor technology** (no moving parts)
- ▶ **Displays both flow rate and volume**
- ▶ **Easy commissioning with multi-language, menu-guided operation**
- ▶ **SIMULATION: All output signals provided without the need for actual flow**
- ▶ **TEACH-IN: Automatic calibration for specific installations**
- ▶ **Fittings available in stainless steel and brass 1/2" – 2" (DN 15 – DN 50), in PVC, PP and PVDF 1/2" – 16" (DN 15 – DN 400)**
- ▶ **CE Approval**

Applications

Flow control of liquids with or without solid particles

Waste water treatment

Surface treatment

Laundries

Chemical industry (non hazardous applications)

Food industry

Auxiliary plants

Swimming pools

bürkert
Fluid Control Systems

Design

The Type 8045 transmitter consists of an insertion magmeter sensor, an electronic circuit board with LCD display and three function keys in a NEMA 4 (IP 65) enclosure. The sensor, with two electrodes, is constructed of PVDF and has a stainless steel grounding ring which contacts the process fluid.

The transmitter amplifies and converts a measured signal. It displays flow rate, two total flow values and its current output in milliamperes, which is proportional to the actual flow rate. All output signals are provided via cable plug or cable gland.

Principle of Operation

The E-shaped magnetic system built into the sensor induces a magnetic field into the fluid, which is perpendicular to the direction of flow. The two electrodes are in galvanic contact with the fluid. Based on Faradays' Law, a voltage can be measured proportional to the speed of flow of a liquid in a pipe. The liquid must have a minimum conductivity of $20\mu\text{S}$. Using the J-factor for an individual pipe diameter, the speed of flow is then converted into volume per unit of time, i.e. gpm or m³/hr.

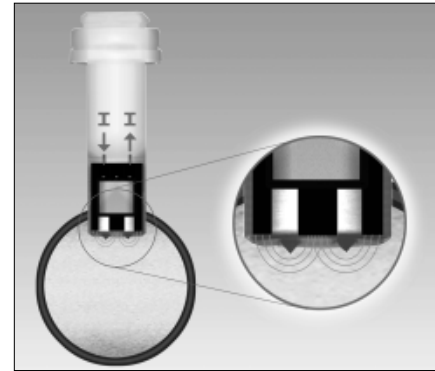

Installation

The Type 8045 flow transmitter can be installed directly into any standard Burkert insertion fitting. For a standard installation, it is recommended that there be 10 pipe diameters of straight pipe section upstream and 3 pipe diameters downstream of the transmitter.

For fluid systems consisting of a transmitter in line with a valve, it is recommended that the fluid pass through the transmitter first, then the valve.

The Type 8045 flow transmitter can be installed in either horizontal or vertical pipes. In horizontal pipes, the transmitter can be oriented anywhere around the circumference of the pipe

except at the 6 o'clock or 12 o'clock positions. In vertical pipe runs, the preferred installation is in a pipe with the flow moving in the upward direction, that is, flow from the bottom to the top. Once installed, the display may be rotated in 90° increments to optimize the viewing angle.

The proper pipe size for a given application is selected using the diagram on the next page. Pressure and temperature limitations must be considered when selecting the installation fitting material. See the next page for the limits of our PVC, PP, and PVDF fittings.

The flow transmitter is not designed for gas flow measurement.

Operation / Start-Up

The device is calibrated by means of the K-factor or via the TEACH-IN function. Customized adjustments such as measuring range, engineering units, pulse output and filter setting are performed on site.

Pressure-Temperature-Diagram for plastics

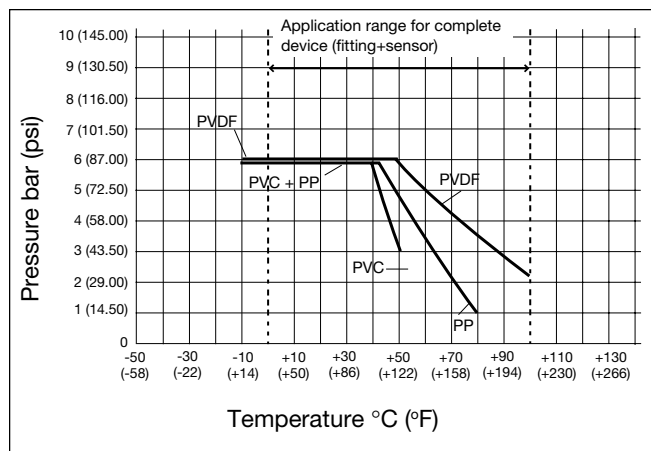

Examples of fitting selection

The suitable pipe size is selected using the diagram next page.

Example 1:
Specification of nominal flow: 10 m³/h
Ideal flow velocity: 2 – 3 m/s
For these specifications, the diagram indicates a pipe size of DN 40.

Example 2:
Specification of nominal flow: 50 gpm
Ideal flow velocity: 8 fps
For these specifications, the diagram indicates a pipe size of 1-1/2".

Flow Rate – Flow Velocity – Pipe Size

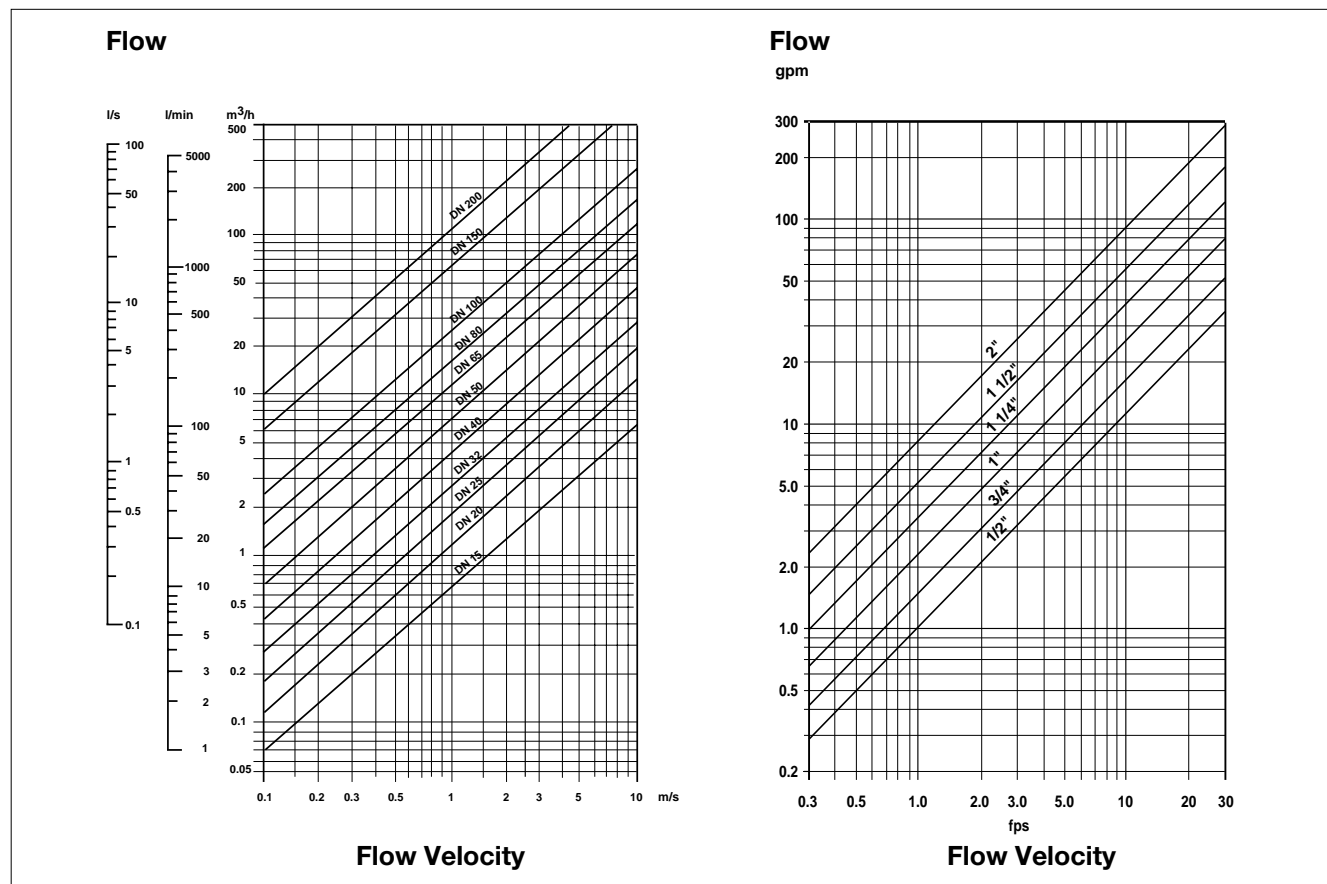

Operation and Display

The unit is operated in the following 3 different menus:

► **Operation menu**

- Flow
- Output current
- Main totalizer
- Daily totalizer and reset function

► **Calibration menu**

- Language
- Engineering units
- K-factor/Teach-in function using volume or master calibration
- Measuring range 4–20mA
- Pulse output
- Relay (optional)
- Filter
- Reset of main totalizer

► **Simulation menu**

- Adjust Zero and Span
- Simulate flow in dry-run operation

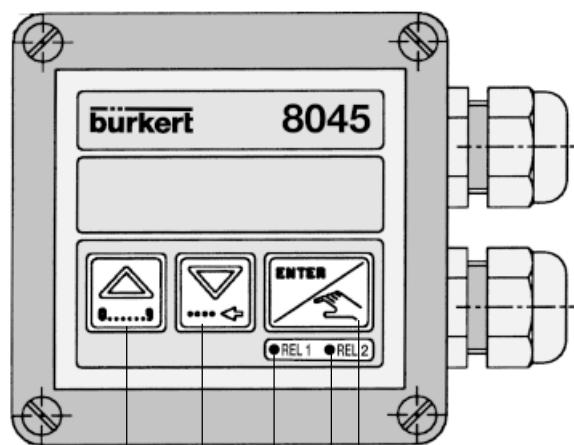

Alter numerical value of selected digit

Run through menu, select digit

Relay 1 LED (optional)

Relay 2 LED (optional)

Confirm input and menu points

Technical Data

General Data

Measuring range	0.16 – 33 fps (0.05 - 10 m/s)
Measuring error	1. With individual works calibration (on request) or Teach-In: $\leq \pm 2\%$ o.R. 1 – 10 m/s (3.2 – 33 fps)* 2. With standard mean K-factor: $\leq \pm 4\%$ o.R. 1 – 10 m/s (3.2 – 33 fps)*
Linearity	$\leq \pm(1\% \text{ o.R.} + 0.1\% \text{ o.F.S.})$ *
Repeatability	$\pm 0.25\%$ o.R. *
Temp. coefficient	1/2" (DN15) = +0.2 % /K ¹⁾ 3/4" & 1" (DN20, DN25) = +0.1 % /K ¹⁾ >1" (>DN25) = +0.05 % /K ¹⁾ ¹⁾ Reference temperature
Display	15x60 mm (.6x2.4"), 8-digit LC-display, alphanumeric, 15 segments, 9 mm tall (0.35" tall)
Fluid conductivity	> 20 μ S (Micro-Siemens)
Fluid temperature max.	PVC: 32°F to 122°F (0°C to 50°C); PP: 32°F to 176°F (0 to 80°C); PVDF: 32°F to 176°F (0°C to 80°C); Brass, Stainless Steel: 32°F to 176°F (0°C to 80°C);
Ambient temperature	32°F to 140°F (0°C to 60°C)
Storage temperature	32°F to 140°F (0°C to 60°C)
Pressure class	87 PSI (PN 6)
Enclosure	NEMA 4 (IP 65)
Sensor material	Body in PVDF, electrodes Stainless Steel
O-rings	FPM (Viton) standard
Housing	Polycarbonate
Front plate foil	Polyester
Fittings	Are available for the following pipe sizes and materials
Pipe diameters	Stainless steel: 1/2" to 2" (DN15 to DN50); 2-1/2" to 14" (DN65 to DN350) (weld-o-let) Brass: 1/2" to 2" (DN15 to DN50) PVC, PP, PVDF: 1/2" to 2" (DN15 to DN50) (true union, solvent spigot) 2-1/2" to 8" (DN65 to DN200) (saddle); 2-1/2" to 16" (DN65 to DN400) (weld-o-let)
Power supply	12–30 VDC, 3-wire
Output signal	4–20mA
Load	Max. 900 Ω at 30 VDC Max. 500 Ω at 24 VDC Max. 100 Ω at 15 VDC
Pulse output	Open collector NPN and PNP, 0–30 V, 100mA, protected Option: Reed relay closing 0.1 s, opening depending on flow rate, minimum is 0.1 s Switches max. 34 VDC, 0.2 AMPS
Relay output (optional)	2 relays, freely programmable, 3 A, 230 V

* Under reference conditions, i.e. measuring fluid = water, ambient and water temperature = 68°F, applying the minimum inlet and outlet pipe straights, matched inside pipe dimensions
o.R. = of reading
o.F.S. = of full scale (10 m/s)(33 fps)

Dimensions [mm (inch)]

Compact Version Standard

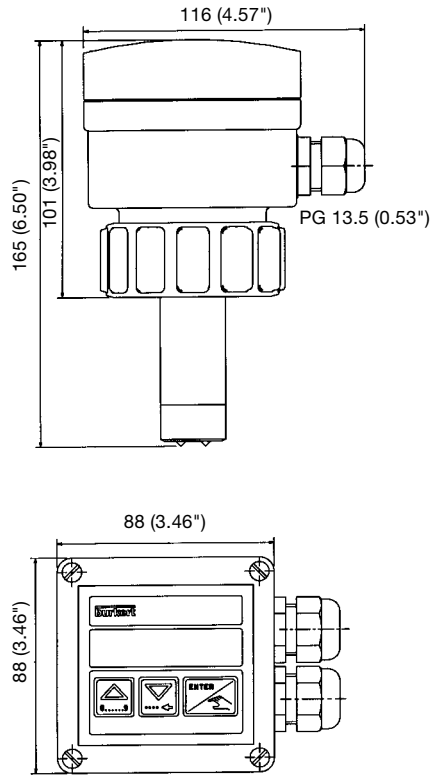

Compact Version North America

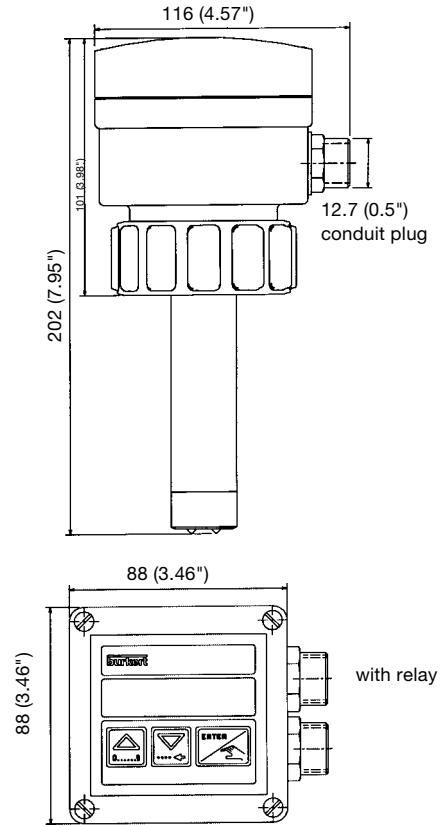

Dimensions [mm (inch)] - Fittings S020, 1/2" - 2" (DN 15 - 50)

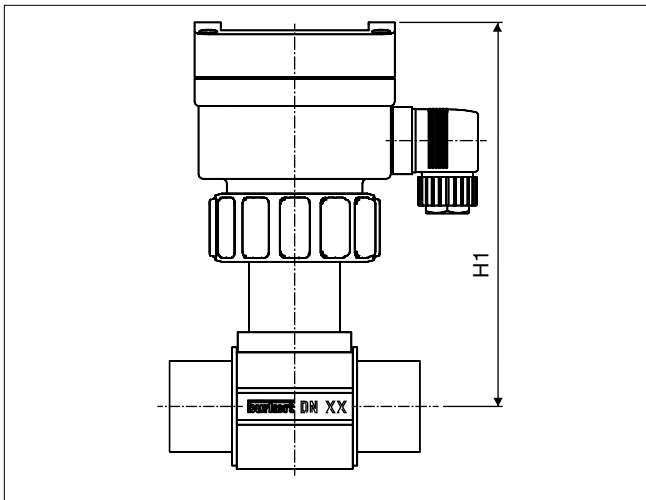

Variable Dimensions [mm (inch)]

DN	H4
15 (1/2)	173 (6.8)
20 (3/4)	171 (6.7)
25 (1)	171 (6.7)
32 (1-1/4)	177 (6.9)
40 (1-1/2)	178 (7)
50 (2)	184 (7.2)

Applicable for all fitting materials
DN 15 - 50 sizes and process
connections.

True Union - PVC, PP, PVDF

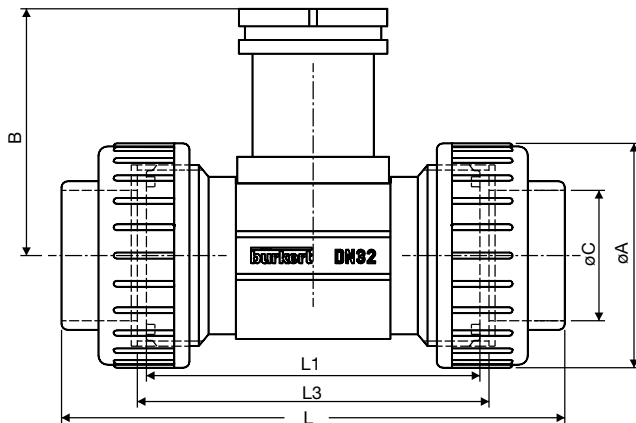

Solvent Spigot - PVC, PP, PVDF

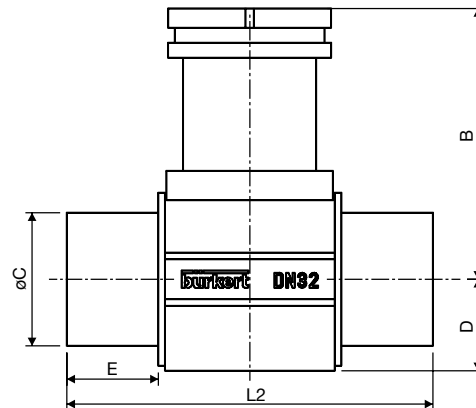

Size	B	øA	L			øC			L1	L3
			DIN	ANSI	JIS	(DIN)	(ANSI)**	(JIS)*		
15 (1/2)	80.4 (3.16)	43 (1.70)	128 (5.03)	130 (5.11)	129 (5.07)	20 (0.78)	21.3	18.40 (0.72)	90 (3.54)	96 (3.77)
20 (3/4)	77.8 (3.06)	53 (2.08)	144 (5.66)	145.6 (5.73)	145 (5.70)	25 (0.98)	26.7	26.45 (1.04)	100 (3.93)	106 (4.17)
25 (1)	78.0 (3.10)	60 (2.36)	160 (6.30)	161.4 (6.35)	161 (6.33)	32 (1.25)	33.4	32.55 (1.28)	110 (4.33)	116 (4.56)
32 (1-1/4)	81.4 (3.20)	74 (2.91)	168 (6.61)	170.0 (6.69)	169 (6.65)	40 (1.57)	42.2	38.60 (1.52)	110 (4.33)	116 (4.56)
40 (1-1/2)	85.2 (3.35)	83 (3.26)	188 (7.40)	190.2 (7.48)	190 (7.48)	50 (1.96)	48.3	48.70 (1.92)	120 (4.72)	127 (5.00)
50 (2)	91.5 (3.60)	103 (4.05)	212 (8.35)	213.6 (8.41)	213 (8.38)	63 (2.48)	60.3	60.80 (2.39)	130 (5.11)	136 (5.35)

Size	D	L2		E	
		PVC	PP/PVDF	PVC	PP/PVDF
15 (1/2)	17.5 (0.68)	90 (3.54)	85 (3.34)	16.5 0.64	14 0.55
20 (3/4)	17.5 (0.68)	100 (3.93)	92 (3.62)	20.0 0.78	16 0.62
25 (1)	21.5 (0.84)	110 (4.33)	95 (3.74)	23.0 0.90	18 0.70
32 (1-1/4)	27.5 (1.08)	110 (4.33)	100 (3.93)	27.5 1.08	20 0.78
40 (1-1/2)	31.5 (1.24)	120 (4.72)	106 (4.17)	30.0 1.18	23 0.90
50 (2)	39.5 (1.55)	130 (5.11)	110 (4.33)	37.0 1.46	27 1.06

* only for PVC with true union

** for STD, U.S. piping, only for PVC with true union

Dimensions - Fittings S020, 1/2" - 2" (DN 15 - 20)

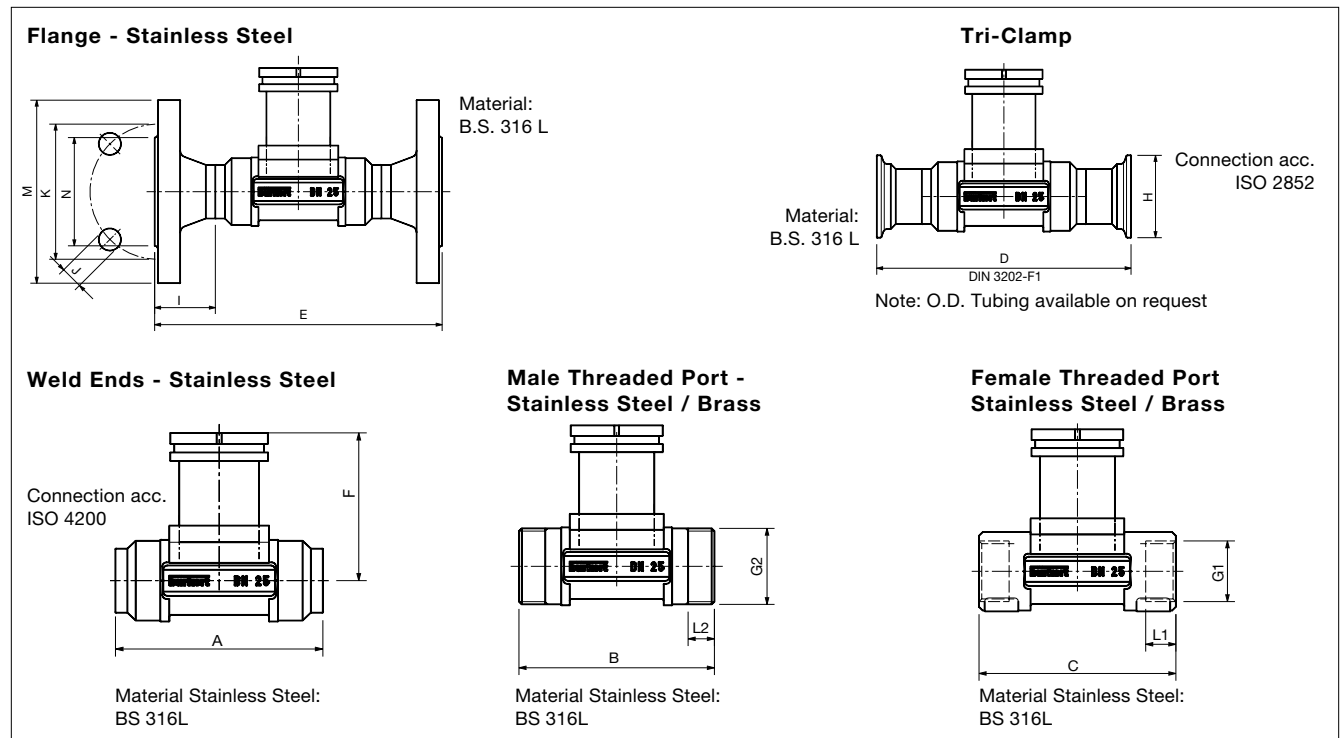

Variable dimensions [mm (inch)] for Weld ends, Male threaded port, Female threaded port, Flange, Tri-Clamp® (ISO 2852)

Size mm (inch)	Weld ends		Length dimensions							Thread				Tri-Clamp® H	Flange dimensions					
	ø outside	Wall thickness	A	B	C	D	E (DIN) (ANSI)	E (JIS)	F	G1	L1	G2	L2		Norm*	I	J	K	M	N
15 (1/2)	21.3 (0.83)	1.6 (0.06)	84 (3.30)	84 (3.30)	85 (3.34)	130 (5.11)	130 (5.11)	140 (5.51)	80.3 (3.16)	G 1/2	16.0 (0.62)	G 3/4	11.5 (0.42)	34.0 (1.34)	DIN	23.5 (0.92)	4x14.0 (0.55)	65.0 (2.55)	95 (3.74)	45.0 (1.77)
										NPT 1/2	17.0 (0.66)				ANSI	23.5 (0.92)	4x15.8 (0.62)	60.3 (2.37)	89 (3.50)	34.9 (1.37)
										Rc 1/2	15.0 (0.59)				JIS	23.5 (0.92)	4x15.0 (0.59)	70.0 (2.75)	95 (3.74)	51.0 (2.00)
20 (3/4)	26.9 (1.06)	1.6 (0.06)	94 (3.70)	94 (3.70)	95 (3.74)	150 (5.90)	150 (5.90)	152 (5.98)	77.8 (3.06)	G 3/4	17.0 (0.66)	G 1	13.5 (0.53)	50.5 (1.98)	DIN	28.5 (1.12)	4x14.0 (0.55)	75.0 (2.95)	105 (4.13)	58.0 (2.28)
										NPT 3/4	18.3 (0.72)				ANSI	28.5 (1.12)	4x15.8 (0.62)	69.8 (2.74)	99 (3.89)	42.9 (1.68)
										Rc 3/4	16.3 (0.64)				JIS	28.5 (1.12)	4x15.0 (0.59)	75.0 (2.95)	100 (3.93)	56.0 (2.20)
25 (1)	33.7 (1.32)	2.0 (0.07)	104 (4.09)	104 (4.09)	105 (4.13)	160 (6.29)	160 (6.29)	165 (6.49)	78.0 (3.07)	G 1	23.5 (0.92)	G 1 1/4	14.0 (0.55)	50.5 (1.98)	DIN	28.5 (1.12)	4x14.0 (0.55)	85.0 (3.34)	115 (4.52)	68.0 (2.67)
										NPT 1	18.0 (0.70)				ANSI	28.5 (1.12)	4x15.8 (0.62)	79.4 (3.12)	108 (4.25)	50.8 (2.00)
										Rc 1	18.0 (0.70)				JIS	28.5 (1.12)	4x19.0 (0.74)	90.0 (3.54)	125 (4.92)	67.0 (2.63)
1-1/4" (32)	42.4 (1.66)	2.0 (0.07)	110 (4.33)	110 (4.33)	120 (4.72)	180 (7.08)	180 (7.08)	170 (6.69)	81.6 (3.21)	G 1 1/4	23.5 (0.92)	G 1 1/2	18.0 (0.70)	60.5 (2.38)	DIN	31.0 (1.22)	4x18.0 (0.70)	100 (3.93)	140 (5.51)	78.0 (3.07)
										NPT 1 1/4	21.0 (0.82)				ANSI	31.0 (1.22)	4x15.8 (0.62)	88.9 (3.50)	117 (4.60)	63.5 (2.50)
										Rc 1 1/4	21.0 (0.82)				JIS	31.0 (1.22)	4x19.0 (0.74)	100.0 (3.93)	135 (5.31)	76.0 (2.99)
40 (1-1/2)	48.3 (1.90)	2.0 (0.07)	129 (5.07)	129 (5.07)	130 (5.11)	200 (7.87)	200 (7.87)	190 (7.48)	85.4 (3.36)	G 1 1/2	23.5 (0.92)	M55x2	19.0 (0.74)	64.0 (2.51)	DIN	36.0 (1.41)	4x18.0 (0.70)	110.0 (4.33)	150 (5.90)	88.0 (3.46)
										NPT 1 1/2	20.0 (0.78)				ANSI	36.0 (1.41)	4x15.8 (0.62)	98.4 (3.87)	127 (5.00)	73.0 (2.87)
										Rc 1 1/2	19.0 (0.74)				JIS	36.0 (1.41)	4x19.0 (0.74)	105.0 (4.13)	140 (5.51)	81.0 (3.18)
50 (2)	60.3 (2.37)	2.6 (0.10)	149 (5.86)	149 (5.86)	150 (5.90)	230 (9.05)	230 (9.05)	216 (8.50)	91.5 (3.60)	G 2	27.5 (1.08)	M64x2	20.0 (0.78)	77.5 (3.05)	DIN	41.0 (1.61)	4x18.0 (0.70)	125.0 (4.92)	165 (6.49)	102.0 (4.01)
										NPT 2	24.0 (0.94)				ANSI	41.0 (1.61)	4x19.0 (0.74)	120.6 (4.74)	152 (5.98)	92.1 (3.62)
										Rc 2	24.0 (0.94)				JIS	41.0 (1.61)	4x19.0 (0.74)	120.0 (4.72)	155 (6.10)	96.0 (3.77)

*Flange: DIN 2501/2633, length according to DIN 3202-F1; ANSI B16-5-1988, length according to DIN 3202-F1; JIS 10K, length according to ANSI B16-10

Dimensions - Fittings 2-1/2" to 14" (DN 65 - 350)

Weld-O-Let Fittings with Radius - Stainless Steel

Material: 316L (B.S.)

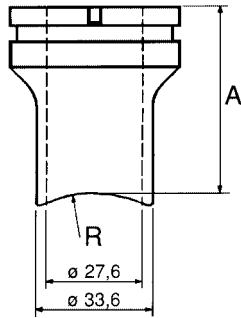

Variable Dimensions [mm (inch)]

Size (inch)	A	R
	54.52 (2.15)	36.65 (1.44)
80 (3)	53.07 (2.09)	44.45 (1.75)
100 (4)	50.71 (2.00)	57.15 (2.25)
125 (6)	48.24 (1.90)	70.65 (2.78)
150 (7)	45.73 (1.80)	84.15 (3.31)
200 (8)	41.01 (1.61)	109.55 (4.31)
250 (10)	73.64 (2.90)	136.55 (5.38)
350 (14)	63.94 (2.52)	177.80 (7.00)

Note:

Short sensor version for: 2-1/2" to 8" (DN 65 - DN 200)
Long sensor version for: 10" to 14" (DN 250 - DN 350)

Dimensions [mm (inch)] - Fittings 2-1/2" x 16" (DN 65 - 400)

Saddle - PP

Body material: PP/PVC
Seal material: EPDM

Note:

These saddle fittings require the long sensor version of the flow indicator Type 8045 for all sizes.

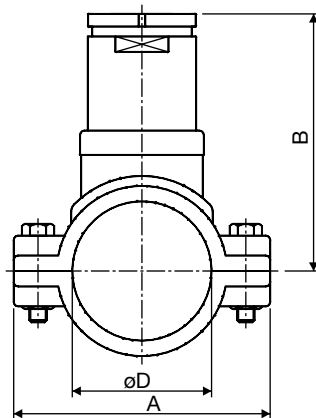

Variable Dimensions [mm (inch)]

Size (inch)	A	B	øD
50 (2)	116 (4.57)	111.1 (4.37)	63 (2.48)
65 (2-1/2)	129 (5.08)	110.0 (4.33)	75 (2.95)
80 (3)	144 (5.67)	113.9 (4.48)	90 (3.54)
100 (4)	166 (6.54)	118.7 (4.67)	110 (4.33)
150 (6)	216 (8.50)	131.5 (5.18)	160 (6.30)
200 (8)	290 (11.42)	174.0 (6.85)	225 (8.86)

Weld-O-Let Fittings - PE, PP, PVDF

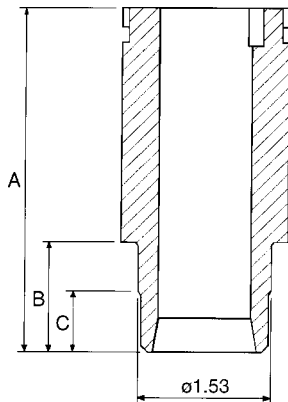

Variable Dimensions [mm (inch)]

Size (inch)	A	PE		PP		PVDF	
		B	C	B	C	B	C
65 (2-1/2)	72.5 (2.85)	13.0 (0.51)	—	13.0 (0.51)	—	10.4 (0.41)	—
80 (3)	72.5 (2.85)	15.6 (0.61)	—	15.6 (0.61)	—	12.5 (0.49)	—
100 (4)	72.5 (2.85)	19.0 (0.75)	5 (0.20)	19.0 (0.75)	5 (0.20)	15.2 (0.60)	6 (0.24)
150 (6)	102 (4.02)	27.7 (1.09)	10 (0.39)	27.7 (1.09)	10 (0.39)	—	—
200 (8)	102 (4.02)	38.9 (1.53)	16 (0.63)	38.9 (1.53)	16 (0.63)	—	—
250 (10)	102 (4.02)	48.4 (1.91)	21 (0.83)	48.4 (1.91)	21 (0.83)	—	—
300 (12)	102 (4.02)	61.3 (2.41)	28 (1.10)	61.3 (2.41)	28 (1.10)	—	—
350 (14)	102 (4.02)	61.3 (2.41)	28 (1.10)	61.3 (2.41)	28 (1.10)	—	—
400 (16)	102 (4.02)	69.1 (2.72)	31.5 (1.24)	69.1 (2.72)	—	—	—

Note:

Short sensor version for: 2-1/2" to 4" (DN 65 - DN 100)
Long sensor version for: 6" to 16" (DN 150 - DN 400)

Ordering Data for Flow Transmitter Type 8045

Compact 4–20 mA INSERTION MAGMETER TRANSMITTER – STANDARD TYPES NORTH AMERICA

TYPE DESCRIPTION	VOLTAGE	SEAL MATERIAL	SENSOR	ELECTRICAL CONNECTION	ITEM-NO.
Magmeter without Relays					
8045 w. 4-20 mA, Pulse, 2x Totalizers	12-30 VDC	FPM	Mag, short	1/2" conduit entry (1 ea.)	426 514 G
8045 w. 4-20 mA, Pulse, 2x Totalizers	12-30 VDC	FPM	Mag, long	1/2" conduit entry (1 ea.)	426 515 H
8045 w. 4-20 mA, Pulse, 2x Totalizers	12-30 VDC	EPDM	Mag, short	1/2" conduit entry (1 ea.)	426 516 A
8045 w. 4-20 mA, Pulse, 2x Totalizers	12-30 VDC	EPDM	Mag, long	1/2" conduit entry (1 ea.)	426 517 B

Magmeter with Relays					
8045 w. 4-20, 2x Relays, Pulse, 2x Total.	12-30 VDC	FPM	Mag, short	1/2" conduit entry (2 ea.)	426 522 G
8045 w. 4-20, 2x Relays, Pulse, 2x Total.	12-30 VDC	FPM	Mag, long	1/2" conduit entry (2 ea.)	426 523 H
8045 w. 4-20, 2x Relays, Pulse, 2x Total.	12-30 VDC	EPDM	Mag, short	1/2" conduit entry (2 ea.)	426 524 A
8045 w. 4-20, 2x Relays, Pulse, 2x Total.	12-30 VDC	EPDM	Mag, long	1/2" conduit entry (2 ea.)	426 525 B

Compact 4–20 mA INSERTION MAGMETER TRANSMITTER – STANDARD TYPES WORLDWIDE

TYPE DESCRIPTION	VOLTAGE	SEAL MATERIAL	SENSOR	CABLE CONNECTOR	ITEM-NO.
Magmeter without Relays					
8045 w. 4-20 mA, Pulse, 2x Totalizers	12-30 VDC	FPM	Mag, short	1xPG 13.5	426 498 R
8045 w. 4-20 mA, Pulse, 2x Totalizers	12-30 VDC	FPM	Mag, long	1xPG 13.5	426 499 J
8045 w. 4-20 mA, Pulse, 2x Totalizers	12-30 VDC	EPDM	Mag, short	1xPG 13.5	426 500 X
8045 w. 4-20 mA, Pulse, 2x Totalizers	12-30 VDC	EPDM	Mag, long	1xPG 13.5	426 501 L

Magmeter with Relays					
8045 w. 4-20, 2x Relays, Pulse, 2x Total.	12-30 VDC	FPM	Mag, short	2xPG 13.5	426 506 R
8045 w. 4-20, 2x Relays, Pulse, 2x Total.	12-30 VDC	FPM	Mag, long	2xPG 13.5	426 507 J
8045 w. 4-20, 2x Relays, Pulse, 2x Total.	12-30 VDC	EPDM	Mag, short	2xPG 13.5	426 508 T
8045 w. 4-20, 2x Relays, Pulse, 2x Total.	12-30 VDC	EPDM	Mag, long	2xPG 13.5	426 509 U

Ordering Data of Stainless Steel Fittings Type S020

Size	Materials	Item-No.
SS - Female NPT-Threaded Ports		
1/2"	SS, FPM	428 742 E
3/4"	SS, FPM	428 743 F
1"	SS, FPM	428 744 G
1 1/4"	SS, FPM	428 745 H
1 1/2"	SS, FPM	428 746 A
2"	SS, FPM	428 747 B
SS - Female G-Threaded Ports		
DN 15	SS, FPM	428 736 Y
DN 20	SS, FPM	428 737 Z
DN 25	SS, FPM	428 738 A
DN 32	SS, FPM	428 739 B
DN 40	SS, FPM	428 740 Q
DN 50	SS, FPM	428 741 D
SS - Female ISO7 (JIS) Threaded Ports		
DN 15	SS, FPM	428 748 L
DN 20	SS, FPM	428 749 M
DN 25	SS, FPM	428 750 J
DN 32	SS, FPM	428 751 F
DN 40	SS, FPM	428 752 G
DN 50	SS, FPM	428 753 H
SS- Male G Threaded Ports		
DN 15	SS, FPM	428 754 A
DN 20	SS, FPM	428 755 B
DN 25	SS, FPM	428 756 C
DN 32	SS, FPM	428 757 D
DN 40	SS, FPM	428 758 N
DN 50	SS, FPM	428 759 P
SS - Weld Ends (ISO 4200)		
DN 15	SS, FPM	428 760 L
DN 20	SS, FPM	428 761 H
DN 25	SS, FPM	428 762 A
DN 32	SS, FPM	428 763 B
DN 40	SS, FPM	428 764 C
DN 50	SS, FPM	428 765 D
SS - Tri-Clamp (ISO 2852) (O.D. Tubing on Request)		
DN 15	SS, FPM	428 766 E
DN 20	SS, FPM	428 767 F
DN 25	SS, FPM	428 768 Q
DN 32	SS, FPM	428 769 R
DN 40	SS, FPM	428 770 N
DN 50	SS, FPM	428 771 B
SS - DIN Flanges (DIN 2501)		
DN 15	SS, FPM	428 772 C
DN 20	SS, FPM	428 773 D
DN 25	SS, FPM	428 774 E
DN 32	SS, FPM	428 775 F
DN 40	SS, FPM	428 776 G
DN 50	SS, FPM	428 777 H
SS - Flanges (JIS 10K)		
DN 15	SS, FPM	431 053 J
DN 20	SS, FPM	431 054 K
DN 25	SS, FPM	431 055 L
DN 32	SS, FPM	431 056 M
DN 40	SS, FPM	431 057 N
DN 50	SS, FPM	431 058 X

Size	Materials	Item-No.
SS - ANSI Flanges (ANSI B16-5-1988)		
1/2"	SS, FPM	428 778 J
3/4"	SS, FPM	428 779 K
1"	SS, FPM	428 780 H
1-1/4"	SS, FPM	428 781 W
1-1/2"	SS, FPM	428 782 X
2"	SS, FPM	428 783 Y
SS - Weld-o-let		
DN 65	SS	418 112 M
DN 80	SS	418 113 N
DN 100	SS	418 114 P
DN 125	SS	418 115 Q
DN 150	SS	418 116 R
DN 200	SS	418 117 J
DN 250	SS	418 756 A
DN 300	SS	420 070 G
DN 350	SS	416 637 R

Ordering Data of Brass Fittings Type S020

Size	Materials	Item-No.
Brass - Female NPT-Threaded Ports		
1/2"	Brass, FPM	428 718 E
3/4"	Brass, FPM	428 719 F
1"	Brass, FPM	428 720 C
1-1/4"	Brass, FPM	428 721 Z
1-1/2"	Brass, FPM	428 722 S
2"	Brass, FPM	428 723 T
Brass - Female G-Threaded Ports		
DN 15	Brass, FPM	428 712 Y
DN 20	Brass, FPM	428 713 Z
DN 25	Brass, FPM	428 714 S
DN 32	Brass, FPM	428 715 T
DN 40	Brass, FPM	428 716 U
DN 50	Brass, FPM	428 717 V
Brass - Female ISO7 (JIS) Threaded Ports		
DN 15	Brass, FPM	428 724 U
DN 20	Brass, FPM	428 725 V
DN 25	Brass, FPM	428 726 W
DN 32	Brass, FPM	428 727 X
DN 40	Brass, FPM	428 728 G
DN 50	Brass, FPM	428 729 H
Brass - Male G/metric Threaded Ports		
DN 15	Brass, FPM	428 730 E
DN 20	Brass, FPM	428 731 T
DN 25	Brass, FPM	428 732 U
DN 32	Brass, FPM	428 733 V
DN 40	Brass, FPM	428 734 W
DN 50	Brass, FPM	428 735 X

Ordering Data of Plastic Fittings Type S020

Diameters	Materials	Item-No.
PVC - True Union ASTM (Cement Joint, STD. U.S. Piping)		
1/2"	PVC, FPM	428 682 T
3/4"	PVC, FPM	428 683 U
1"	PVC, FPM	428 684 V
1 1/4"	PVC, FPM	428 685 W
1 1/2"	PVC, FPM	428 686 X
2"	PVC, FPM	428 687 Y
PVC - True Union ISO		
DN 15	PVC, FPM	428 670 J
DN 20	PVC, FPM	428 671 F
DN 25	PVC, FPM	428 672 G
DN 32	PVC, FPM	428 673 H
DN 40	PVC, FPM	428 674 A
DN 50	PVC, FPM	428 675 B
PVC - True Union JIS		
DN 15	PVC, FPM	429 078 H
DN 20	PVC, FPM	429 079 A
DN 25	PVC, FPM	429 080 Y
DN 32	PVC, FPM	429 081 M
DN 40	PVC, FPM	429 082 N
DN 50	PVC, FPM	429 083 P
PVC - Solvent Spigot		
DN 15	PVC, FPM	428 676 C
DN 20	PVC, FPM	428 677 D
DN 25	PVC, FPM	428 678 N
DN 32	PVC, FPM	428 679 P
DN 40	PVC, FPM	428 680 D
DN 50	PVC, FPM	428 681 S
PE - Weld-O-Let		
DN 65	PE	418 642 G
DN 80	PE	418 643 H
DN 100	PE	418 644 A
DN 150	PE	418 645 B
DN 200	PE	418 646 C
DN 250	PE	418 647 D
DN 300	PE	418 648 N
DN 350	PE	418 649 P
DN 400	PE	418 598 V
PVC - Saddle		
2-1/2"	PVC, NBR	413 469 W
3"	PVC, NBR	413 470 T
4"	PVC, NBR	U S50 B20
6"	PVC, FPM	U S50 B17
8"	PVC, FPM	U S50 B42

Diameters	Materials	Item-No.
PP - True Union with G Threaded Port		
DN 15	PP, FPM	428 688 H
DN 20	PP, FPM	428 689 A
DN 25	PP, FPM	428 690 F
DN 32	PP, FPM	428 691 U
DN 40	PP, FPM	428 692 V
DN 50	PP, FPM	428 693 W
PP - Weld Ends		
DN 15	PP, FPM	428 694 X
DN 20	PP, FPM	428 695 Y
DN 25	PP, FPM	428 696 Z
DN 32	PP, FPM	428 697 S
DN 40	PP, FPM	428 698 B
DN 50	PP, FPM	428 699 C
PP - Weld-O-Let		
DN 65	PP	418 650 L
DN 80	PP	418 651 H
DN 100	PP	418 652 A
DN 150	PP	418 653 B
DN 200	PP	418 654 C
DN 250	PP	418 655 D
DN 300	PP	418 656 E
DN 350	PP	418 657 F
PP - Saddle (Metric Piping)		
DN 50	PP, PVC, FPM	425 138 N
DN 65	PP, PVC, FPM	425 139 P
DN 80	PP, PVC, FPM	425 140 U
DN 100	PP, PVC, FPM	425 141 R
DN 110	PP, PVC, FPM	425 142 J
DN 125	PP, PVC, FPM	425 143 K
DN 150	PP, PVC, FPM	425 144 L
DN 200	PP, PVC, FPM	425 416 D
PVDF - True Union with G Threaded Port		
DN 15	PVDF, FPM	428 700 R
DN 20	PVDF, FPM	428 701 E
DN 25	PVDF, FPM	428 702 F
DN 32	PVDF, FPM	428 703 G
DN 40	PVDF, FPM	428 704 H
DN 50	PVDF, FPM	428 705 A
PVDF - Weld Ends		
DN 15	PVDF, FPM	428 706 B
DN 20	PVDF, FPM	428 707 C
DN 25	PVDF, FPM	428 708 M
DN 32	PVDF, FPM	428 709 N
DN 40	PVDF, FPM	428 710 A
DN 50	PVDF, FPM	428 711 X
PVDF - Weld-O-Let		
DN 65	PVDF	418 658 Q
DN 80	PVDF	418 659 R
DN 100	PVDF	418 660 N



Easy Continuous
Pneumatic Control



savings up to
60%



Easy ON/OFF Control



savings up to
50%

