

**FloSen®** **Series JFM-P**  
**Airflow Measuring Probes**



The Series JFM-P FloSen® Airflow Measuring Probes provide accurate, repeatable measurement of air movement in HVAC ducts. Its patented elliptically-shaped sensor design with improved aerodynamic characteristics outperforms more traditional devices, and overcomes loss of accuracy caused by fluid separation at the sensor body. It is designed to maintain a constant parallel airflow pattern over the static sensing ports for more accurate, steady signals under all duct conditions. The elimination of separation results in a stabilized static pressure signal, helping to eliminate “hunting” during fan control.

FloSen® Airflow Probes utilize a unique in-line groove for total pressure sensing and dual ports for static pressure sensing which produces a higher differential pressure for very low velocity measurements. The total and static pressure measuring points are distributed for equal-area averaging of flows resulting in improved accuracy and reliability. This design permits accurate and stable measurement in highly turbulent flow locations with directional pitch and yaw varying up to 20 degrees without the need for air flow straighteners which restrict airflow and can easily become clogged. The elliptical shape of the FloSen® Airflow Probes allows air to glide unrestricted around the aerodynamically designed sensors and offers the lowest pressure drop of any airflow measuring device available minimizing HVAC operating costs.

The FloSen® Airflow Probes have been designed for easy installation and maintenance. The insertion-style probes can be completely installed from outside the duct. The quantity of FloSen® Airflow Measuring Probes selected for each duct size is based on ASHRAE and AMCA standards to produce assured airflow measuring accuracy over a flow turn-down ratio of 17:1.

Features

- 1% Accuracy
- Aero-Dynamic Elliptical Shape
- Easy Installation
- No Straightener Required
- Wide Turn-Down Ratio
- Minimum Pressure Drop

Probe Shape Comparison

*Round vs. Ellipse*



- Low static pressure signal affected by separation.
- Vacuum effects limit turn-down ratio to 4 to 1
- Variable intensity vortices generated downstream, creates signal amplifications, vibrations and acoustic problems
- High drag coefficient creates high pressure loss



- Flow boundary layers attached to probe surface
- No separation effects
- No vacuum effects
- No vortex generation
- Low drag coefficient
- High repeatability

## SPECIFICATIONS

**Velocity Range:** 300 – 5000 FPM (1.5 – 25 m/s)

**Probe Length:** 8 – 120" (200 – 3000mm)

**Accuracy:** +/- 1% F.S.

**Repeatability:** +/- 0.1% F.S.

**Temperature Ranges:** -40° to 180°F (-40° to 80°C)

**Turn-Down Ratio:** 17:1

**Pressure Loss:** 0.004" w.c. @ 700 FPM

**Materials:** Anodized Aluminum or PVC

**Pressure Connections:** ¼" ID tubing

## DIMENSIONAL DRAWINGS

**JFM-PE (Externally Mounted)**

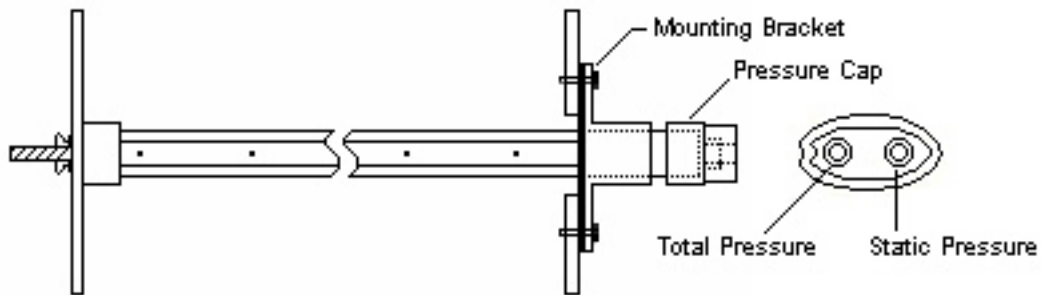

**JFM-PE (Self-supported)**

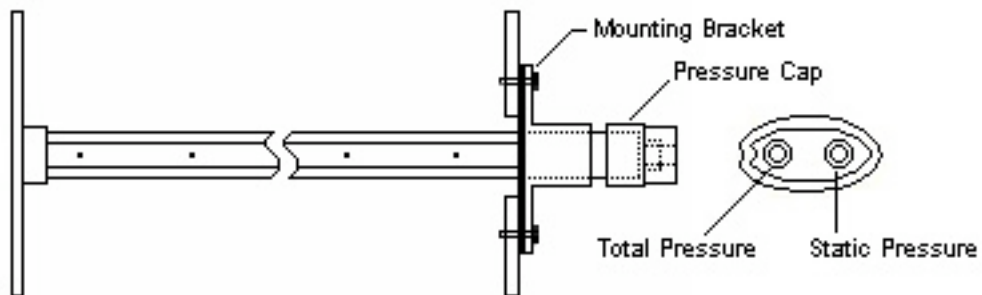

**External Mounting Plat**

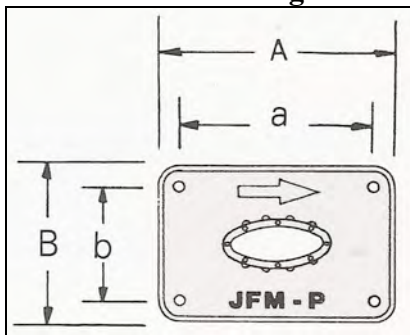

**Probe Insertion Cut-out**

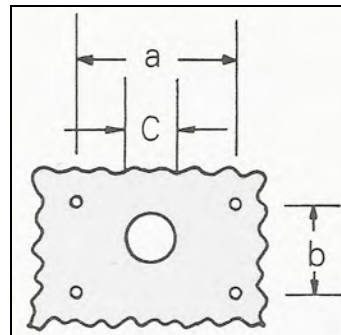

**End Support Cut-out**

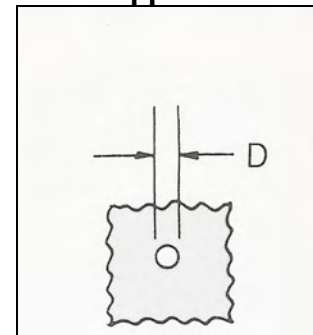

**JFM-P Dimension Chart (inches)**

	A	a	B	b	C	D
Aluminum Probe	3.54	2.91	2.36	1.73	1.58	.39
PVC Probe	4.33	3.74	2.76	2.17	1.58	.39

## PROBE QUANTITIES

The number of FloSen® Airflow Measuring Probes for a given application has been selected based on ASHRAE and AMCA Standards to produce assured airflow measuring accuracy.

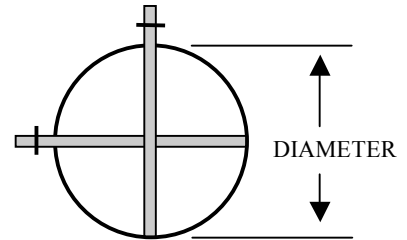
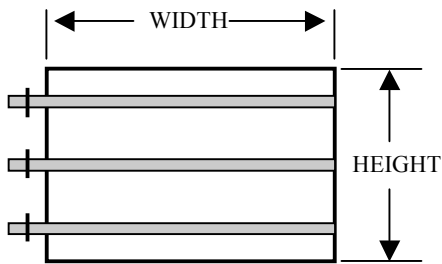

### For Square and Rectangular Ducts

Height Dimension	FloSen® Probes Required	Height Dimension	FloSen® Probes Required
8" – 12"	1	35" – 56"	4
13" – 22"	2	57" – 80"	5
23" – 34"	3	81" – 120"	6

### For Circular Ducts

Diameter	FloSen® Probes Required
8" – 24"	1
25" +	2

## INSTALLATION REQUIREMENTS

Rectangular Duct

$$X = \frac{2(L \times H)}{L + H}$$

Circular Duct

$$X = \text{Duct Diameter}$$

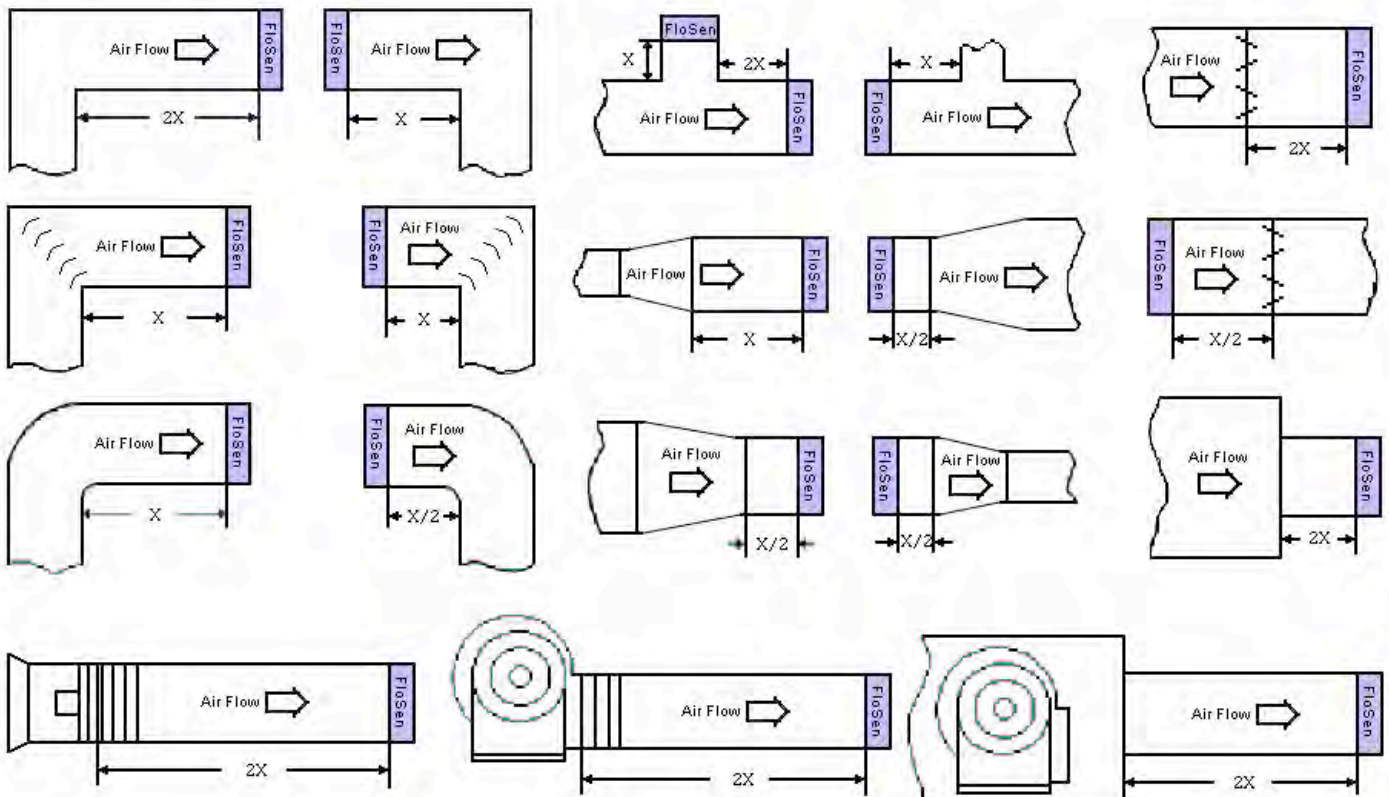

---

## ORDERING INFORMATION

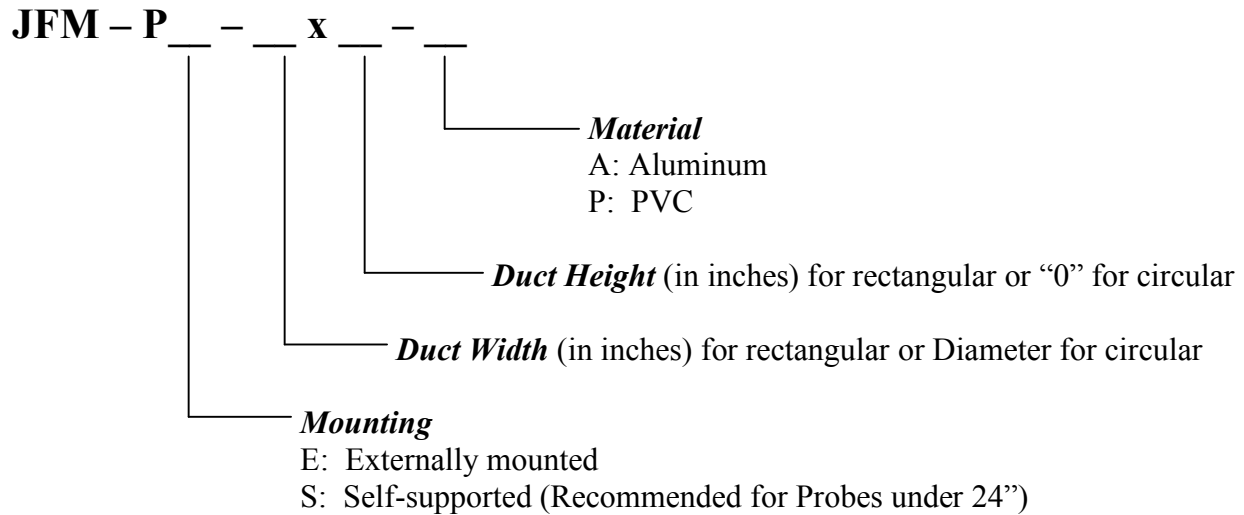

**Example:** JFM - PE - 42 x 34 – A  
(3) 42” Aluminum JFM Airflow Probes for External mounting in a 42” x 34” duct

---

## SUGGESTED SPECIFICATION

- Provide where indicated and/or scheduled an array of airflow measuring probes capable of continuously measuring and monitoring the duct air volumes they serve.
- The airflow measuring probe shall contain multiple total and static pressure sensing ports placed along the exterior surface of the elliptically-shaped probe body and internally connected to their respective averaging chambers.
- The airflow measuring probes shall be capable of producing amplified steady non-pulsating signals of total and static pressure and of measuring the air volumes within an accuracy of +/- 1% for operating velocities from 300 to 10,000 feet per minute (fpm) with the use of the same flow coefficient and without the use of airflow straightening means.
- The airflow measuring probes shall allow air to glide unrestricted around the aerodynamically designed probe body, shall not cause fluid separation at the probe body, and shall not create a pressure loss, greater than 0.004 inch w.c. at 700 fpm.
- The total pressure sensing ports shall be located at the centers of equal areas (for rectangular ducts) or equal concentric areas (for circular ducts) along the probe length.
- The airflow measuring probe shall be Sensocor, Inc. Series JFM-P or equal as approved by the Engineer.

---

## ACCESSORIES



The Series A4 Digital Differential Pressure Control is a perfect companion to the FloSen® Model JFM-P Airflow Probes. By entering the duct dimensions and flow coefficient of the Probes, the Series A4 will display the reading in CFM or the equivalent metric unit. The Series A4 is capable of providing a 4-20 mA square root output based on a user defined flow range and also has relays available for setpoint alarms or other on off indication.

**A4111** Digital Differential Pressure Control with relay and 4-20 mA outputs